

Platinum partner



AIR TRANSPORT DEPARTMENT

FACULTY OF OPERATION AND ECONOMICS OF TRANSPORT AND COMMUNICATIONS

UNIVERSITY OF ŽILINA

International Conference on Air Transport

10 – 11 November 2016
Vienna, Austria



International Conference on Air Transport

10 – 11 November 2016
Vienna, Austria

International Conference on Air Transport

ISSN 2454-0471



9 788055 412733

www.edis.uniza.sk



International Conference on Air Transport

10 – 11 November 2016
Vienna, Austria

AIR TRANSPORT DEPARTMENT
FACULTY OF OPERATION AND ECONOMICS OF TRANSPORT AND COMMUNICATIONS
UNIVERSITY OF ŽILINA



International Conference on Air Transport

10 – 11 November 2016

Vienna, Austria

(page intentionally left blank)

Foreword



Prof. Dr. Tony Kazda

Conference Chair

University of Žilina, Slovakia

Dear participants,

it is my great pleasure to welcome you to the fifth edition of INAIR conference, this time in beautiful Vienna, Austria.

Even if the conference has scientific status, we are trying to invite industry to the discussion in order to understand current industry needs. The INAIR conference is a forum in which Industry and Academia meet to exchange ideas and set up common challenges. The interaction between researchers and industry representatives is a key in order to come up with innovative solutions for the challenges of the future.

Air Transport is nowadays mainly covered in topics like airport planning (infrastructure development); the criteria of success are defined in terms of number of runways, apron stands, terminal facilities etc. Airport capacity shortage requires optimal usage of existing infrastructure. The impact of climate change and resource shortage increases the complexity. Aviation has to optimize its overall capacity usage within even tighter constraints. Resilience of the aviation system is becoming a big issue; reliability of schedules and procedures for all stakeholders involved (including passengers and local communities in the airports neighbourhood) is at stake. Disturbances due to severe weather, technical issues etc. might cause huge delays and costs. Solving these challenges require a mind shift towards changing and optimizing processes, innovation in infrastructure usage, logistics and cooperation between partners.

I believe that papers presented in these proceedings and the follow-up discussion will contribute to suitable solutions for the current needs of aviation sector.

Scientific Board

Prof. Antonín Kazda, Air Transport Department, *University of Žilina*, Slovakia

Col. (ret.) Prof. Jaroslaw Kozuba, *Polish Air Force Academy in Deblin*, Poland

Dr. Prof. h.c. Vladimír Němec, *Czech Technical University in Prague*, Czech Republic

Dr. Vasco Reis, *Instituto Superior Técnico - Universidade de Lisboa*, Portugal

William J. Muldoon, *Embry-Riddle Aeronautical University*, USA

Prof. John Wensveen, *Purdue University*, West Lafayette, USA

Geert Boosten, *Amsterdam University of Applied Sciences*, Netherlands

Chair of the Scientific Committee:

Prof. Andrej Novák, *Head of Air Transport Department, University of Žilina*, Slovakia

Peer review

All papers in these proceedings were subject to peer review by the members of Scientific Board.

Organization Board

Juliana Blašková

Antonín Kazda

Martin Hromádka

Šimon Holoda

Filip Škultéty

E-mail

inair@fpedas.uniza.sk

kld@fpedas.uniza.sk

TABLE OF CONTENTS

Al-Hilfi, S.; Loskot, P.:	
ARRIVAL AND DEPARTURE FLIGHT STATISTICS FOR THE LARGEST AIRPORT HUBS	7
Badánik, B.:	
AIRLINES HAVE GONE VIRTUAL AND SOCIAL.....	15
Bartoš, M.; Badánik, B.:	
INNOVATIVE APPROACH IN PROVISION OF AIR NAVIGATION SERVICES IN EUROPE.....	22
Brezoňáková, A.; Badánik, B.:	
ASPECTS OF FLIGHT CREW FATIGUE.....	28
Ficová, D.; Badánik, B.:	
EFFECTS OF HIGH LEVEL OF AUTOMATION IN THE AIRCRAFT COCKPIT ENVIRONMENT ON PILOT SKILLS AND FUTURE TRAINING REQUIREMENTS.....	33
Götz, K. et al.:	
DEVELOPMENT OF A RISK ASSESSMENT TOOL FOR SESAR'S DESIGN-IN SECURITY APPROACH	41
Guglieri, G.; Ristorto, G.:	
SAFETY ASSESSMENT FOR LIGHT REMOTELY PILOTED AIRCRAFT SYSTEMS.....	45
Hankovská, J.; Badánik, B.:	
THE IMPACT OF SAFETY AND SECURITY STANDARDS ON COMFORT IN BUSINESS AVIATION	54
Hromádka, M.; Škultéty, F.:	
PUBLIC SERVICE OBLIGATION ON EU AVIATION MARKET	58
Kazda, A.; Mrázová M.:	
LOW COST MARKET EVOLUTION – EDIFICATION FROM THE PAST, VISIONS OF FUTURE	64
Kováčová, M. et al.:	
IS IT JUST CULTURE MEASURABLE? – CAN WE MODEL THE JUST CULTURE CONCEPT?.....	68
Kozuba, J.:	
SELECTED ASPECTS OF APPLYING MODERN TECHNOLOGIES IN AVIATION TRAINING, EXEMPLIFIED BY POLISH AIR FORCE ACADEMY IN DĘBLIN.....	74

Kurdel, P. et al.:	
EVALUATION OF ASYMPTOTIC LEARNING OF OPERATOR – PILOT IN SYMBIOTIC SIMULATOR ENVIRONMENT	
.....	84
Lusiak, T. et al.:	
USE OF SPLIT TRAILING EDGES OF AILERONS AND THEIR IMPACT ON NUMERICAL ANALYSIS OF FLUENT AIR	
STREAM REFER TO POLISH JET TRAINER AIRCRAFT T3-11 SPARK	89
Magalhães, L. et al.:	
MODELLING FLEXIBLE OPTIONS AT PASSENGER TERMINALS – AN APPLICATION TO LISBON AIRPORT	98
Mesarsova, K.:	
EMPOWERING YOUR EMPLOYEES TO A BETTER FATIGUE MANAGEMENT IN HIGH RISK INDUSTRY	104
Novák, A.; Žáčik, N.:	
RESEARCH AND EDUCATIONAL LABORATORIES OF AIR TRANSPORT DEPARTMENT AT THE UNIVERSITY OF	
ŽILINA	110
Solkin, M.; Loskot, P.:	
ANALYSIS AND SIMULATION OF AIR COLLISION AVOIDANCE SYSTEM	115
Steinheimer, M. et al.:	
AIR TRAFFIC MANAGEMENT AND WEATHER: THE POTENTIAL OF AN INTEGRATED APPROACH	120
Sužnjević, M. et al.:	
GNSS FINAL APPROACH TRAJECTORY ANALYSIS FOR GENERAL AVIATION AIRCRAFT	127
Škultéty, F.; Hromádka, M.:	
IMPLEMENTATION OF OBSTACLE COLLISION AVOIDANCE SYSTEM INTO HEMS	132
Vas, T.:	
REMOTE TOWER SPECIFICATIONS IN DEPLOYABLE AIRBASES	137
Zaharia, S. E.:	
MAJOR TRENDS IN THE RELATION AIRPORT – AIRLINERS IN THE CENTRAL AND EASTERN EUROPE	143

ARRIVAL AND DEPARTURE FLIGHT STATISTICS FOR THE LARGEST AIRPORT HUBS

Sarah Al-Hilfi

College of Engineering, Swansea University, United Kingdom
808746@swansea.ac.uk

Pavel Loskot

College of Engineering, Swansea University, United Kingdom
p.loskot@swan.ac.uk

Abstract – Most public datasets about Air Transport represent annual or monthly aggregated data which can be used for longer-term planning and management of airline network operations. However, in order to devise and test new processes, more instantaneous data over shorter-time periods are required. Here, we present our efforts in collecting and evaluating a one week of actual arrival and departure data for 70 largest airport hubs representing over 130 large and small airports. These airports have flight connections with almost 3,000 other airports. The flights dataset was extended with data about characteristics of almost 200 aircraft types and airport time zones. The flights dataset can be used to observe various statistics such as to identify peak and off-peak hours of airports, to find the number of flights between hubs and non-hubs, to find the busiest routes and to understand how different aircraft types are being deployed. From these data, we may even infer the average number of passengers and cargo volumes delivered.

Key words – Airport hubs, arrivals data, departures data, flights data, statistics.

INTRODUCTION

The passenger numbers and cargo volumes in Air Transport are projected to increase steadily over at least next 20 years. Such growth has to be met by the corresponding capacity increases of airports and other supporting infrastructures which often require updating the existing operational processes. One example of these new developments is our proposal for dissociating passengers from their baggage (Loskot, 2015). Such dissociation will require fundamental changes in operational, legal and safety regulations, however, once implemented, it will also enable to consider passenger-

only and baggage-only airports, airport terminals and aircraft. In order to evaluate feasibility and benefits of such proposal, we need to model the airline networks including models for aircraft and airports. These models are likely to be obtained from Air Transport data. Even though Air Transport industry is collecting enormous amount of data from all levels of their operations, vast majority of this data are not publicly accessible for privacy and business reasons. For this reason, we have collected one week of arrivals and departures data for 70 largest airport hubs which may enable to test and analyse new concepts and solutions in designing and organizing airline networks and providing air transport services. However, our data does not involve operational nor capital expenditure costs which are critical factors influencing the whole Air Transport industry.

In order to cope with increasing expansion of air travel, the aviation sector has to continue innovations and investments to maintain the profitability and to respond to changes in passenger expectations. The innovation efforts in Air Transport are focusing on improvements in the efficiency of using resources, improvements in system characteristics (reduction of noise, pollution, congestion, complexity, cost) and improvements in the passenger experience (less waiting, self-sufficiency). The connected passengers are equipped with various personal smart devices, and they are becoming more demanding. The passenger bags are connected to enable their real time tracking and more efficient handling. The aircraft are connected to improve their operational efficiency. However, the connected passengers and things create new challenges, especially in terms of security and privacy.

ACRONYMS

BRS	Baggage Reconciliation System
CAA	Civil Aviation Authority
CSV	Comma-Separated Values
ETA	Estimated TOA
ETD	Estimated TOD
FAA	Federal Aviation Administration
IATA	International Air Transport Association
ICAO	International Civil Aviation Organization
ICT	Information and Communication Technologies
KPI	Key Performance Indicator
MLW	Maximum Landing Weight
MTOF	Maximum Take-off Weight
MZFW	Maximum Zero-Fuel Weight
OEW	Operational Empty Weight
PNR	Passenger Name Record
TCP/IP	Protocols in the Internet
TOA	Time of Arrival
TOD	Time of Departure
UTC	Coordinated Universal Time
XML	Extensible Markup Language

USE OF DATA IN AIR TRANSPORT

It is useful to understand why there is need for data in Air Transport. Air Transport sector is keen to adopt the latest ICT solutions to not only improve its profitability, but also to increase the safety and security. Since the aviation industry operates on small profit margins, it is very sensitive to changes in many factors (e.g. the fuel price, currency exchange rates, competition, deregulation) and passenger attitudes (budget vs. business travellers, seasonality, increasing expectations). The interesting recent trend in evolution of airline networks (deserving more investigation as the usual economies of scale do not apply here) is the preference for smaller, but much more fuel efficient aircraft on a number of less-busy point-to-point connections over large but less fuel efficient high-capacity aircraft deployed on hub-to-hub routes. Some

airlines are now trialling low-cost long-distance routes. In addition, the fuel efficiency of aircraft has direct impact on its payload vs. range performance.

A lot of travel data is generated by provisioning passenger services starting already from flight searches and purchasing tickets (Skyscanner). Such data indicate the trends, what destinations are in demand, the preferences of passengers and how they make decisions in choosing the flights. This in turn may suggest changes in the airline networks, for example, to respond to the route demands and whether opening new flight routes would be viable. The airlines also employ complex algorithms to determine the tickets and cargo pricings. The use of ICT have enabled and will enable many new passenger services such as online check-in and baggage self-tagging. The airline operations require the use of distributed databases such as PNR and BRS. From January 2018, all baggage handling operations and ownership changes have to be recorded (IATA Resolution #753). The airlines are now adopting a new XML based messaging format and are migrating to public TCP/IP networks from the older proprietary systems. The use of open public networks (the Internet) requires using data encryption to ensure their confidentiality and integrity.

Reporting of statistical data by airlines and airports is not unified. Sometimes passengers are counted as passenger-kilometres, and it is not clear how to count transiting passengers (a passenger with one transit may be counted twice by the airlines).

The other and major issue of with data, in general, is the privacy, since travel data are the largest most sensitive, most intimately revealing, most heavily computerized and name-identified. Therefore, the agencies have to treat these data with utmost level of sensitivity, and to comply with government laws and regulations (e.g. EU).

Under the EU data protection rules, all personal data must be provided with a high standard of protection everywhere in the EU, and any persons or organisations that collect and manage personal information must protect it from misuse as well as respect the rights of the data owners. These data regulations create problems when data are shared among parties in and outside of the EU.

Even if data were anonimized and made publicly available, there is another issue with business competition. The business competition can be very intense (IATA estimates there were over 1,300 new airlines established in the past 40 years) and no company is keen to reveal, e.g., their pricing strategies via publishing their data.

In spite of large amounts of data being produced by the Air Transport industry, there are still huge opportunities to devise how to make the best use of these data. The use of data requires to develop appropriate models of systems (e.g., for predictive analytics). The data collection processes are usually driven by the KPIs whose selection is non-trivial (different KPIs are likely to lead to different dynamics of systems being managed). Some KPIs are adaptively modified to account for abnormal behaviour of systems (e.g., airline network disruption due to bad weather, or unexpected aircraft maintenance), or adjusted against the longer-term effects (e.g., seasonal adjustment of revenues).

Arrival and Departure Data for the Largest Airport Hubs

Using different public sources of Air Transport data (see Table 1), actual arrival and departure data for the 70 largest airport hubs (2015 statistics by [Wikipedia]) corresponding to 139 airports of different sizes were collected. The data span approximately one week in the summer 2016. The data records for each airport arrivals, the items reported are:

flight number, aircraft type, origin airport name and its ICAO/IATA code, ETD, TOA;
whereas for departures, we have:

flight number, aircraft type, destination airport and its ICAO/IATA code, ETD, TOA.

Thus, there are two types of airports. The main (or nominal) airports are those 139 airports that are among the 70 airport hubs considered. The other group of airports are those that either the flight originated from and then arrived to a hub airport (arrivals) or that the flight arrived to from a hub airport (departures). The collected data were stored in CSV files within a hierarchical sub-directory structure. Before the data can be analysed, the first task is to pre-process the raw data to remove their several inherent problems. The data processing was done by scripts written in Python to exploit its functionality in working with regular expressions. Thus, the raw data are first parsed to check that the records match the expected CSV pattern. About 10% of records were found not to comply, e.g., due to inclusion of extra or forgotten commas, and in some cases, missing the end-of-line character separating two records. These records were corrected by pattern matching techniques in several parsing rounds until no incorrect record was found. It is then straightforward to identify missing values and replace them with some distinctive character; we used a question mark. Similarly to checking and correcting the incorrect record patterns, it was then necessary to check all record values whether they comply with the expected format. For instance, ICAO airport codes are a group of 4 capital letters, whereas IATA

airport codes are formed by 3 capital letters. This task was complicated by the use of non-standard codes for airports and aircrafts, probably in 10-15% of cases. Especially in data for the US area, the airports are sometimes designated by FAA codes. Moreover, the flight numbers, generally, does not seem to have any standardized format, even though in many cases it is possible to identify the operator from the flight number (however, the actual operator may be different due to flight sharing schemes that many airlines get involved in). In some cases, either only ICAO or IATA code was provided. Eventually, we decided to preferably use ICAO codes to denote both airports and aircraft, so if ICAO code was missing, it was supplied from another CSV file we obtained from the ICAO website. However, even ICAO aircraft codes are not unique nor complete. For instance, the aircraft code may be shared by several versions or modifications of the same aircraft type.

Another problem we encountered was the use of non-English characters in airport names. These characters were found to cause difficulties when importing the CSV files into Excel spreadsheet. Therefore, we first identified all these non-standard letters, and then manually assigned each of these letters to similar letters from the English alphabet. The arrival and departure times were sometimes missing the days of week or the time zones; these missing values could be inferred from the preceding or following data records. We also tried to convert the departure and arrival times to UTC. This was a straightforward task for the times that are given for the main airports among the selected 70 airport hubs. However, the times for originating or terminating airports outside the airport hubs have the problem of not being unique, since these other airports are often located in very diverse geographical areas. We found that some time zone acronyms can resolve to as much as 4 different time zones. Even though it is possible to decode the correct time zone for a given airport knowing its geographical location, we did not find such data from the Internet for smaller and less often used airports (about 25% of the airports in the data).

EVALUATION OF ARRIVAL AND DEPARTURE DATA

The cleaned up and corrected raw data can be evaluated. We used combination of Python scripts as well as processing in Excel spreadsheets; the latter to generate tables, graphs and other data visualizations. The data processing is performed again in several stages as shown in Figure 1. We found it is useful to generate new CSV files containing results of the intermediate processing steps. It is particularly beneficial when the processing

pipeline is not serialized, but various processing steps are combined in a tree-like structure (see Figure 1).

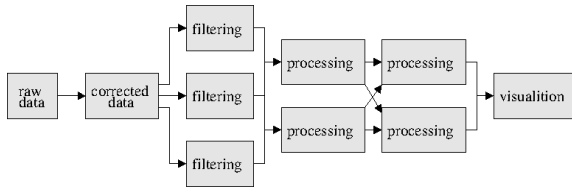

Figure 1: Data evaluation and visualization.

For instance, the filtering step usually removes data fields that are not relevant to the problem at hand. It is often easier to process and combine these intermediate data files than to devise how to work directly with the root data file.

More importantly, it was recognized that some other supporting data are required in the processing of our arrival and departure data. Specifically, we compiled a new data file containing typical aircraft characteristics as shown in Table 2. The focus is on different weight characteristics, payloads, maximum range, fuel and seating capacity in order to obtain the payload-range curves, and to determine maximum loading of the aircraft including the delivery efficiency. The aircraft price may be used in evaluation of the flight economics. However, the aircraft price can vary significantly even for the same type of aircraft from the same manufacturer as price deals are common for bulk orders. We then also create a CSV file for airports (see Table 3) which contains, for every airport, its name, location (city and country), code designators (ICAO and IATA/FAA), the time zone shift against UTC, latitude/longitude coordinates and the size (small, medium or large). This file is partly sourced from other existing similar files we discovered on the Internet, however, data especially for small airports (time zones and locations) and many medium size airports must be searched and included manually which is a very time consuming process.

In the sequel, we will present and discuss several examples generated from our data. First, we evaluated the statistics of aircraft types for flights to/from the largest airport hubs. These statistics are shown in Table 8. It is obvious that by far, the most popular aircraft types are Airbus A320 and Boeing B737 which are deployed on short to medium routes around the world. These aircraft are especially

popular by low-cost airlines who are often operating a large fleet of just one aircraft type to achieve significant acquisition and operational cost reductions (e.g., EasyJet operates only A320 while Ryanair only owns B737). The aircraft type statistics differ among Europe, Asia and America (not shown), probably reflecting the different markets, habits and flying attitudes by passengers.

Next we evaluate flights to/from airports within the London hub, i.e., Heathrow, Gatwick, Luton, Stansted and Southend with the first two airports being considered to be the hubs by themselves. The basic data about these airports are given in Table 4. Table 5 lists the most connected airports from these 5 London hub airports, and we note that the number of flights is counted over one week of our data. Table 7 provides the breakdown of the origin airports for arrivals to Heathrow in and CDG airport in Paris. We can observe that the flights from non-EU and EU airports is balanced for Heathrow, while the EU flights are slightly prevailing for CDG airport. The aircraft type statistics for 5 London airports are given in Table 6. The differences among the airports are mainly reflecting the presence of different airlines (traditional versus low-cost) who specialize on different types of routes. For example, the hub-and-spoke routes are flown by traditional airlines whereas direct routing is usually preferred by low-cost carriers to connect more regional (and thus, cheaper) airports.

Figures 2 and 3 compare the total number of flights for three major airport hubs selected in Europe, Asia and America. These curves confirm that there are almost no flights for several hours after midnight (noise abatement, economical and passenger convenience measures). The total daily arrivals show a three-modal distribution (three peaks) for Atlanta airport while a uni-modal distribution was found for Heathrow with the busiest day of the week being Monday. On the other hand, Beijing sees the busiest travel times to be over the weekend, from Friday to Sunday. Similar differences in the total daily number of flights (arrivals and departures) can be observed among 5 London hub airports as shown in Figure 4. Interestingly, traffic in Luton and Southend airports is mostly uniform over the week days while the busiest airports of the hub, Heathrow and Gatwick, experience largest variations over the week with a clear peak demand on Monday (Heathrow) and Friday-Sunday (Gatwick).

Table 1: Public sources of Air Transport data

Source	Access	Datasets
OpenFlights.org	free	search, filtering, statistics of almost 3 million flights, and API ¹
FlightRadar24.com	free/paid	info on airports and traffic, operators, real-time and historical data
Airportia.com	free	flights by airports or airlines
FlightAware.com	free/paid	extensive ADS-B support, search flights by status (cancelation, delayed etc.), real-time and historical data
ArcGIS.com ²	free	visualization of ICAO international & domestic traffic flows with filtering capability
CAA.co.uk ³	free	monthly updated air transport statistics for the UK
AT Multiplex project ⁴	free	air transport data for major as well as low-cost airlines
Eurostat ⁵	free	various statistics including transport
Enac.fr ⁶	paid	large air transport datasets
BTS, USA ⁷	free	wide range of transport data for the USA
arm.64hosts.com	free	program for exploring route maps of over 550 airlines
US airports project ⁸	free	airport networks in the US

¹ <https://github.com/jpatokal/openflights>

² <http://www.arcgis.com/home/webmap/viewer.html?webmap=abe4516f02af466db1f7c6376d485b85>

³ <https://www.caa.co.uk/Data-and-analysis/UK-aviation-market>

⁴ <http://complex.unizar.es/~atnmultiplex/>

⁵ <http://ec.europa.eu/eurostat/data/database>

⁶ <http://www.enac.fr/en/air-transport-database>

⁷ <http://www.rita.dot.gov/bts/>

⁸ <https://toreopsahl.com/datasets/#usairports>

Table 2: Data sample of aircraft characteristics for most common Airbus and Boeing aircraft types

Type	MTOW [kg]	MLW [kg]	MZFW [kg]	OEW [kg]	Cargo vol. or Max. payload [kg]	Seats Typical	Seats HD	Fuel Capacity [L]	Range with max. payload [km]	Price [mil. \$]
A320	73 500 - 77 000	64 500 - 66 000	62 500	42 100	18 600	150	180	23 860 - 29 840	5 350 - 5 550	98
A318	59 000 - 68 000	56 000 - 57 000	53 000	39 500	13 300	107	117	23 860	2 750 - 6 000	75
A319	75 500	62 500	58 500	40 800	27.70 m ³	124	156	24 210	6 900	90
A321	93 500	77 800	73 800	48 500	51.70 m ³	185	220	24 050-30 030	7 400	114
A330-300	233 000	182 000	175 000	173 000	158.4 m ³	295	400	139 090	10 501	254
A330-200	242 000	182 000	170 000	120 150-120 750	132.4 m ³	247	406	139 090	13 450	232
A380	560 000	386 000	361 000	276 800	83 000	550	700	310 000	15 000	404
A340	271 000 - 275 000	192 000	181 000	130 900	50 900	295	440	141 500	13 100 - 13 500	238.0
A350-900	280 000	207 000	195 700	134 700-145 100	36m ³ or 11 pallets	325	440	165 000	15 000	308
A350-800	259 ,000	193 ,000	181 000	?	28m ³ or 9 pallets	280	440	138 000	15 400	272
A350-1000	308 000	233 000	220 000	155 000	44m ³ or 14 pallets	366	440	156 000	14800	356
B737-800	B78 240 - 79 000	65 317	75000	41 413	43.6 m ³	160	189	26 020	7 408	98
B737-300	62 800-68 000	51 700	48 410	32 700	23.3 m ³	128	149	23 830	5 463	47
B777-300	263 080 - 299 370	237 680	224 530	155 500 - 158 480	66 050	396	550	171 170	7 500 - 11 000	279
B777-300ER	317 520 - 351 800	251 290	237 680	168 700	68 500	396	550	181 283	11 390-14 600	320
B737-900	79 000	66 360	62 730	42 490	20 240	177	215	26 030	5 080	69
B739 737-900ER	85 200	71 400	67 800	44 676	52.5 m ³	85	215	29 660	5 900	102
B767-300	158 760	136 080	126 100	86 070	40 230	269	328	63 200	9 700	199
B767-300ER	186 880	145 150	133 810	90 010	43 800	269	328	91 380	11 000	186
B777-200ER	263 080 - 297 560	208 650 - 213 190	195 000 - 199 580	135 600 - 143 800	51 250	305	440	171 170	10 750 - 14 300	277
B777-200LR	322 050 - 347 800	220 900 - 223 170	206 840 - 209 110	155 580 - 156 030	50 850	305	440	202 500	15 040 - 17 450	314
B787-3	170 000	161 000	?	101 000	4 400 ft ³	290	330	12,830 US gal (48,600)	5 500	?
B787-8	227950	172365	161 025	119 950	136.7 m ³	242	359	124 700	14 500	225
B747-400	363 200 - 396 900	260 360 - 295 740	251 740	181 120	70 620	416	660	204 340 - 216 840	11 440 - 13 430	234
B747-400ER	412 780	265 740	251 740	183 840	67 900	416	660	228 250 - 241 140	13 900 - 14 200	267
B787-9	254011	192777	181437	128 850	172.5 m ³	290	406	138 700	15 370	265
B747-8	440 000	306 200	288 000	211 900	76 300	467	660	243 400	14 800	357

Table 3: Data sample of airports

Airport Name	City	Country	IATA-FAA	IACO	Time Zone (UTC)	Latitude	Longitude	Type
Ocean Reef Club	Ocean Reef Club	United States	OCA	07FA	-5	25.3253994	-80.27480316	Small
Sky Ranch At Carefree	Carefree	United States		18AZ	-7	33.81809998	-111.8980026	Small
Honiara Int'l	Honiara	Solomon Islands	HIR	AGGH	11	-9.42800045	160.0549927	Medium
Port Moresby/Jackson Int'l	Port Moresby	Papua New Guinea	POM	AYPY	10	-9.44338036	147.2200012	Large
Keflavik Int'l	Keflavik	Iceland	KEF	BIKF	0	63.98500061	-22.60560036	Large
Reykjavik	Reykjavik	Iceland	RKV	BIRK	0	64.12999725	-21.94059944	Medium
Pristina Int'l	Pristina	Kosovo	PRN	BKPR	2	42.57279968	21.03580093	Large
Brampton	Brampton	Canada		CNC3	-5	43.76029968	-79.875	Medium
Collingwood Airport	Collingwood	Canada		CNY3	-5	44.44919968	-80.15830231	Small
Sault Ste. Marie	Sault Sainte Marie	Canada	YAM	CYAM	-5	46.48500061	-84.50939944	Medium
Campbell River	Campbell River	Canada	YBL	CYBL	-8	49.95080185	-125.2710037	Medium
Cornwall Regional	Cornwall	Canada	YCC	CYCC	-5	45.09280014	-74.56330109	Medium
Nanaimo	Nanaimo	Canada	YCD	CYCD	-8	49.05497022	-123.8698626	Medium
Centralia/James T. Field Memorial Aerodrome	Centralia, Ontario	Canada	YCE	CYCE	-5	43.28559875	-81.50830078	Medium
Chatham-Kent	Chatham-Kent, Ontario	Canada	XCM	CYCK	-4	42.3064003	-82.08190155	Small
Charlo	Charlo	Canada	YCL	CYCL	-4	47.99079895	-66.33029938	Medium
Deer Lake Regional (Newfoundland)	Deer Lake	Canada	YDF	CYDF	-4	49.21080017	-57.39139938	Medium
Edmonton Int'l	Edmonton	Canada	YEG	CYEG	-7	53.30970001	-113.5800018	Large
Elliot Lake Municipal	Elliot Lake, Ontario	Canada	YEL	CYEL	-5	46.35139847	-82.56140137	Medium

Table 4: Basic information about London hub airports

Airport	Heathrow	Gatwick	Luton	Stansted	Southend
IATA	LHR	LGW	LTN	STN	SEN
ICAO	EGLL	EGKK	EGGW	EGSS	EGMC
Latitude	51.4775	51.1481	51.8747	51.8850	51.5714
Longitude	-0.4614	-0.1903	-0.3683	0.2350	0.6956
Elevation	83	202	526	348	49
Timezone	+01:00	+01:00	+01:00	+01:00	+01:00
Runways	2 (3)	1	1	1	1
Pax annually	75 mil	40 mil	12.2 mil	22.5 mil	0.9 mil

Table 5: Most frequent origins and destinations in one week for London hub airports

EGLL				EGKK				EGGW				EGSS				EGMC			
Arrivals		Departures		Arrivals		Departures		Arrivals		Departures		Arrivals		Departures		Arrivals		Departures	
EIDW	153	KJFK	146	LEBL	159	EIDW	207	EKCH	83	EKCH	93	EIDW	102	EIDW	125	EHAM	22	EHAM	23
KJFK	145	EIDW	136	LEMG	151	LEMG	143	EHAM	69	EHAM	62	EGPH	102	EGPH	100	LPFR	18	LPFR	18
EDDF	141	EDDF	130	EIDW	147	LEBL	135	LEBL	66	EIDW	55	EGPF	83	EGPF	79	LEPA	12	LEPA	13
EHAM	136	EHAM	121	LPFR	126	LPFR	128	LLBG	52	LEBL	53	LIRA	65	LIRA	64	LEMG	12	LEMG	12
EDDM	108	LFPG	95	EHAM	126	EHAM	113	LEPA	50	LROP	51	EDDB	64	EDDK	53	LEAL	12	LEAL	12
LFPG	104	EDDM	93	EGAA	115	LEAL	96	LPFR	46	LLBG	51	LIRP	62	LEMG	52	LFPG	7	LFPG	7
OMDB	100	LSGG	92	LEMD	111	EGAA	92	LEMG	46	LHBP	51	EDDK	55	EDDB	52	LEBL	7	EGJJ	7
LSZH	97	LSZH	90	LEAL	110	LIPZ	91	EGPH	41	LEPA	47	LEMD	54	LEMD	49	EGJJ	7	LEBL	6
LSGG	97	LEMD	85	LIPZ	109	EGJJ	91	EGAA	41	LEMG	43	LIME	50	EGAA	49	LEIB	6	LIPZ	4
LEMD	88	OMDB	79	EGJJ	104	LFMN	90	LEAL	39	LPFR	40	EPMO	50	LIRP	48	LIPZ	4	LEIB	4

Table 6: Most frequent aircraft types in one week for London hub airports

EGLL				EGKK				EGGW				EGSS				EGMC			
Arrivals		Departures		Arrivals		Departures		Arrivals		Departures		Arrivals		Departures		Arrivals		Departures	
A320	1315	A320	1163	A320	1748	A320	1574	A319	536	A320	731	B738	2388	B738	2311	A319	110	A319	109
A319	864	A319	779	A319	1683	A319	1503	A320	465	A319	497	A319	395	A319	388	-	-	-	-
A321	487	A321	418	B738	533	B738	522	B738	270	B738	300	A320	59	A320	55	-	-	-	-
B77W	283	B77W	252	A321	271	A321	268	A321	95	A321	141	D328	22	D328	34	-	-	-	-
B772	233	B772	226	B772	131	B772	129	B734	25	B734	24	AT72	14	A321	17	-	-	-	-
B744	217	B744	203	E190	129	E190	110	B739	13	B739	11	DH8D	12	E190	13	-	-	-	-
B763	211	B763	195	B788	53	B744	52	B752	11	B752	9	E190	11	AT72	13	-	-	-	-
A388	209	A388	182	B744	52	B788	49	B763	8	B737	8	A321	11	A332	13	-	-	-	-
B789	139	B789	119	A332	49	B763	49	B733	8	GLF4	7	MD11	10	DH8D	11	-	-	-	-
B788	126	32A	114	B763	48	A332	49	CL60	6	B763	7	B77L	10	B77L	10	-	-	-	-

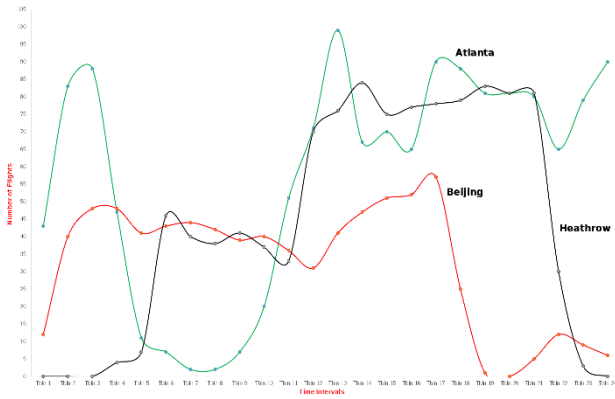

Figure 2: Number of arrivals over a typical week day for 3 selected large airports.

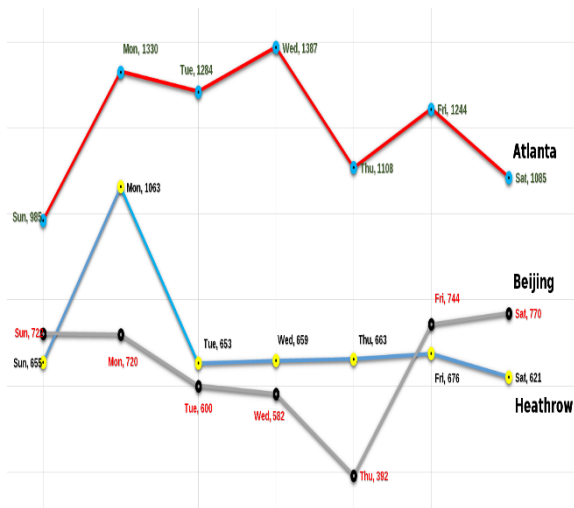

Figure 3: Daily number of arrivals distribution over a week for 3 selected large airports.

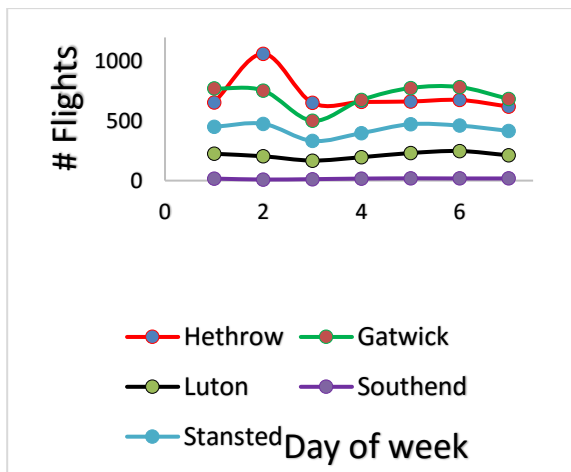

Figure 4: The total daily number of arrivals and departures for 5 London hub airports.

Table 7: The origin airports distribution for 2 large European hub airports.

Flights	Heathrow	CDG Paris
Outside EU	44%	41%
Inside EU	44%	49%
Domestic	12%	10%

Table 8: The aircraft type statistics for one week of data in 70 largest airport hubs.

Type	%	Type	%
A320	19.1	B739	1.9
B738	18.1	B763	1.5
A319	7.3	A332	1.5
A321	6.9	CRJ7	1.4
B737	6.2	B752	1.4
E170	3.3	B772	1.4
A333	2.5	DH8D	1.1
CRJ9	2.1	B733	1.0
E190	2.1	E135	1.0
B77W	2.0	B788	0.9

DISCUSSION

Even relatively short segments (one week, in this paper) of flight data can be very useful to elucidate insights into the structure and operation of airline networks. We may use this data to devise economic models or to optimize transportation of passengers and cargo delivery. Since more detailed data about flights (number of passengers actually travelled, number and weight of baggage, and cargo volume delivered) are either subject to privacy issues or business secrets, it may be sufficient that the authorities (CAA, FAA, governments, airports, airlines) would report, for example, average flight occupancy per aircraft, or average number of flights per day and similar such data that are sufficiently general to constrain their value (for reasons mentioned above), and at the same time, to be more informative than the typically reported monthly or annually aggregated values. Nevertheless, one week of our flight data can be used to infer (approximate) the values we need.

REFERENCES

- [1] Nissalke T. E. Jr., The Air Transportation systems in the 21st century. Chapter in Sustainable Built Environment, Vol. II.
- [2] Baron A., Air Transport Efficiency and its Measures, Trans. of the Inst. of Aviation, no. 205, pp. 119-132.
- [3] Eurocontrol (2009), Challenges of Air Transport 2030 - Survey of experts' views.
- [4] IATA publications. www.iata.org/publications

- [5] Cisco (2009), Smart Airports: Transforming Passenger Experience to Thrive in the New Economy.
- [6] IATA (2016), The Economic and Social Benefits of Air Transport, Fact Sheet.
- [7] Loskot P. and Ball P., Innovative Baggage Delivery for Sustainable Air Transport, In Air 2015.
- [8] Parliament UK (2000). Statistical information on air passenger numbers and characteristics
- [9] Hasbrouck E. (2010), Total Travel Information Awareness, Travel Data and Privacy.
- [10] European commission, Data Protection (online).
- [11] marketrealist.com (2014), The airline industry's growth and impact on economic prosperity. (online)
- [12] The leading airport magazine (2015), The Top 10 airport innovations of 2015 so far. (online)
- [13] SITA documents and presentations: www.sita.aero

AIRLINES HAVE GONE VIRTUAL AND SOCIAL

Assoc. prof. Benedikt Badánik, PhD.

Air Transport Department, University of Žilina, Slovakia

benedikt.badanik@fpedas.uniza.sk

Abstract - Social media is no longer considered to be toys that only serve youngsters for sharing their feelings or what they are doing. Presence on social media and status updates are becoming increasingly important for many companies and institutions. Airlines are no exemption. The world simply communicates through social media. Passengers like to be connected through every stage of their journey. They appreciate being kept posted on flight updates. Social media enables them to be part of this virtual world. That is the reason why airlines should not ignore it and they should make sure they will “cruise” on social media. The paper offers an insights into how and why airlines are “flying Social Media course”. It shows real examples of how the world of social media is exploited by airlines and how the presence of airlines on social media pays off.

Key words - social media, social media profile, hashtag, revenue boosting, social media campaign development, brand ambassador, crisis management, driving customer service through social media, driving revenue through social media

BACKGROUND

Before diving into the world of social media and explaining how this world is conquered by airlines one should define what social media means in general.

Social media could be defined as any platform offering exchange of thoughts or feelings. Good examples of social media include e-magazines, internet forums, social blogs, social networks, podcasts, photographs etc.

The definition of social media is very simple when it comes to the younger generations. Young people usually say that you do not even exist without a Facebook or Twitter account. To put this definition in an every-day perspective, social media is an intangible (virtual) network for sharing thoughts, feelings and other personal information that could have major influence on the tangible (real) world. Social media is frequently used for sharing even very personal feelings and thoughts. In addition, it is becoming more and more popular among masses of users.

Wikipedia suggests that social media is the interaction among people in which they create, share or exchange information and ideas in virtual communities and networks. And it depends on mobile and web-based technologies creating highly interactive platforms through which individuals and communities share, co-create, discuss, and modify user-generated content.

The world simply communicates through social media. Passengers like to be connected through every stage of their journey. They appreciate being kept posted on flight updates. Social media enables them to be part of this virtual world. That is the reason why airlines should not ignore it and they should make sure they will “cruise” on social media.

WHY AIRLINES ARE “FLYING SOCIAL MEDIA COURSE”

Nigam (2014) says that it can be difficult to dive in, but the repercussions can be terrible if airlines choose not to use social media. He used six case studies on Alaska Air, AirBaltic, JetBlue, Southwest Airlines, Volaris and Qantas to illustrate success stories of airlines who believe their presence on social media will help them retain loyalty of passengers. Kahonge (2013) suggests that the studies show the reasons why these airlines are “flying Social Media course”. To put it in a business perspective the objectives of airlines’ presence on social media could be listed as follows:

To build a relationship with passengers

If an airline is capable of handling responses to air travellers’ queries in a timely manner it would naturally be able to build positive perceptions of the airline brand. Passengers always want somebody to be listening to them and they feel comfortable when airlines take their feedback seriously. Maintaining a good relationship with passengers over social media could also help airlines to overcome negative perceptions of their brand when they adopt new features of

their business model (for example: the airline will move from operating point-to-point low-cost services to operation of higher-fares service-minded network of routes). On top of that, airlines maintaining their presence on social media enjoy an excellent opportunity to establish so called two-way relationships with their travelers. It is that type of relationship in which airlines continue to develop their social media content on one hand but on the other hand they also let their followers to create additional content on their own.

To listen to what passengers say and to respond in real-time

This business objective has something to do with keeping passengers posted on their flight updates in real-time. It is of vital importance for passengers to be updated on flight changes especially when the flight is late or there are some other operational disruptions or irregularities like unpredictable delays caused by volcano eruptions. If flight updates are delivered properly and updated in real-time passengers get the information that is accurate. That is something passengers require all the time. As a consequence of that they will perceive the airline as a respectful, reliable and prompt partner that is worth being flown with again in the future.

To drive traffic

Airlines keep on trying to create and offer attractive online content because they feel this can bring huge competitive advantage to them. The airline industry is a typical sector in which airlines compete to attract more passengers. An online presence is seen as a tool that helps airlines become more attractive and to create better value for more passengers. Another aspect that helps airlines drive traffic is a sense of community between the airline and its passengers. Once the sense of community has been established (by the use of social media) the airline benefits from closer relationships with its passengers leading to increased demand for its air services. A good example of how social media drives traffic is the case of Virgin America and JetBlue airlines. Both carriers recorded increased number of clicks on their home web sites after they ran interesting social media campaigns.

To increase awareness about the airline brand

An airline brand is not what you say it is, it's what they say it is (Nigam, 2014). Therefore it is of vital importance for the airline to create and to support positive perception of its brand. If an airline examines passengers' needs and wants properly and in detail, if it keeps its promises, reacts quickly and properly on passengers' queries, and if it is eager to

innovate, passengers will more likely continue considering the airline for their future travel arrangements.

To engage and to interact with passengers

Social media enables effective interaction between airlines and passengers. Airlines are able to handle "tons" of passengers' queries in a short time. Passengers feel comfortably because the airline pays attention to what they think and the airline values their opinions. On top of that, operation of social media channels is inevitably cheaper than operation of traditional communication platforms. Passengers can also enjoy promotional offers of flights that are available only on these virtual channels.

To be transparent in operations

There are some airlines (for example Southwest) that let passengers have a look at how the airline is managed and operated. Southwest created an interesting online show named "Airline" that offers passengers a look "behind the scenes". This allows passengers to see how the airline product is designed and how particular operational problems are tackled. This kind of transparency in operations could then be "sold" to passengers as the following message: "You know Southwest because we share details with you." The outcome of such a campaign could potentially be an increased loyalty of passengers as they feel they know the airline much better.

UNLOCKING THE POTENTIAL OF SOCIAL MEDIA AS REVENUE BOOSTERS

Airline Business Magazine (March 2014) describes the "Christmas Miracle" video of WestJet airline as an example of how airlines make their name online with a view to turn this promotion into an action that would drive revenue.

The idea of the airline was to take departing passengers' Christmas wishes, then to buy stuff they wished and to surprise the passengers at the carousel belt in their final destination where they found their "Christmas wishes fulfilled". The article says that more than 14 million people viewed the video within three days of being loaded online and 35.3 million viewed it before February 5th.

Some keep on arguing that the potential of social media for revenue generating is weak compared to potential of onboard advertising. Easy Jet quantified its on-board advertising revenues up to € 1.43 on a per passenger basis in 2006 (Stefanik, Fakih, Badanik, 2008). It is a good example of how EasyJet successfully quantified its on-board advertising

potential. However, when it comes to the quantification of the potential of social media for revenue boosting it is slightly more complicated.

Those 35.3 million views can also be treated as a group of potential customers who will potentially think of WestJet first when they plan a flight trip in Canada. This is potential that could turn to business when the viewer decides to buy air tickets.

The video is very powerful way of making an airline brands a non-abstract group of letters. Social media is even more than videos. It is about staying in touch with customers and keeping them “connected” to an airline. On top of that there is a potential that relationships with loyal customers will turn to revenue-producing partnership for the airline.

American Airlines is one of the most successful brands when it comes to an active presence on social media. According to Unmetric the airline is now able to reply to over 15,000 tweets a month, with an average reply time of 8 minutes (measured as the time difference between a tweet and a reply). American Airlines is especially quick to apologize to followers. 20% of their tweets apologize to followers (Unmetric, 2014). Director of social communications at American, Jonathan Pierce, says the carrier’s success is a combination of more dedicated staffing with employees from the reservations and customer relations teams, more training and round-the-clock responses (Airline Business Magazine, March 2014). American is now the only US airline tweeting to customers around the clock, continues the article. The airline has aligned its customer support team to manage its online reputation. American has also won “The SimpliFlying Award for Excellence in Social Media” in 2012, category Best Social Customer Service. After the award the team of American expanded to 24/7 response, while it maintained its primary focus to deliver the best social customer service.

Ryanair also sees social media as the opportunity for generating additional revenue. The airline has joined Twitter just recently (in September 2013) but its presence keeps growing. Now the airline is followed by more than 73 000 followers. The airline uses its account primarily for customer care and marketing activities. The airline allows its customers to chat with different members of its senior management team (hour-long Twitter chats take place every week). Ryanair also offers one-hour, one-route flash sales that have become the most popular feature of its site. The sales could become generators of additional revenue in the future.

Airlines dedicating staff and financial resources in social media will gain tangible pay-offs (Airline Business

Magazine, March 2014). The magazine continues with the fact that WestJet generated \$1.6 million in additional revenue and about 6000 new bookings from an April Fool’s YouTube video alone in 2012.

Bearing these figures in mind one can definitely assume that social media helps airlines drive revenue.

KLM airline is another great example of positive return on investment and revenue driving through social media. The airline generates € 3 (in direct and indirect sales) for each € 1 spent on social media (Airline Business Magazine, March 2014). The sales represent a four-time return on investment. It is thanks to the fact that KLM is very well focused and organized on social media. The airline offers the passenger a tailor-made feature on every social media channel the airline is present. For instance, KLM offers real-time assistance for travellers on Twitter where the airline is followed by more than 5.8 million fans. The airline is heavily present on Facebook where it is followed by 925.000 fans. Facebook is used as a crowd sourcing tool trying to collect customers’ ideas on KLM product development. It also lets passengers find an ideal travel mate through “Meet & Seat” function. This diverse but focused approach is considered to be a key to success on social media. Engaging customers in a modern way doesn’t necessarily have to involve a lot of money (Airlinetrends report, 2012). According to the report people want real experiences, genuine messages and real actions from companies, which by definition do not cost a lot of money but require more effort. KLM, for instance, formed the social media team comprised of 40 people out of which 25 work as service agents, others are communication experts, copywriters and the team also has a reputation manager. The report continues that the real-time and public nature of social media requires an internal organization that is equipped to handle every kind of question – from simple information requests to rebooking a flight or selecting a seat – as well as “speak with one voice”, especially in crisis situations where acting quickly and consistently is paramount. The effort that KLM puts into social media activities has already started to pay-off. The experience of the airline is that many travellers literally say that they buy the tickets from the airline because of its actions on social media.

Even if some airlines are able to calculate their return on investment in social media there are others that say the return is more intangible, more a question of how their customers feel. American for instance sees its social media team as “part of customers’ decision to choose American” (Airline Business Magazine, 2014). The magazine continues that Ryanair sees a direct correlation between its flash sales and increased bookings and finds the other returns on investment

not very easy to be quantified. The airline says it is more about doing things less complicated for passengers. That is exactly what social media offers in general. The airline reacts promptly to passengers' comments and the passengers feel comfortable that the airline "is listening" to what they think. Passengers will therefore, more likely, continue considering the airline for their future travel arrangements.

Airline presence on social media could pay off even more if the airline social media campaign is well developed and communicated to travellers.

BEST PRACTICES IN AIRLINE SOCIAL MEDIA PRESENCE

Airline best practices in crisis management through social media

To put general the definition of crisis in an airline perspective, a crisis is a situation resulting from a major internal or external event which impacts upon the airline in the context of public safety, airline staff safety, airline service continuity, or airline reputation and related public confidence (e.g. the terrorist attacks of 11th September 2001). Usually the crisis comes unnoticed and literally out of blue. Serusi (2012) says that crises in the Air Transport industry come in many shapes and forms but they usually have three things in common: 1) no prior notice or warning signs, 2) the need to inform large numbers of people in a very short time and 3) a large number of (increasingly digital) angry/distressed people. He suggests that regardless of whether the crisis is something the airline did to itself, an uncontrollable natural phenomenon or a strike, there is always a need to reach large numbers of people as quickly as possible, providing information, answering their questions and avoiding the spread of false rumors.

McLean (2014) suggests that each crisis shares common themes – surprise, uncertainty, danger, reputation and relationship. He continues that crisis can impact on individuals, families, organizations, communities and even nations. It is often the case that crises lead many organizations to collapse. It is because the crisis finds them completely unprepared and they suffer from lack of information, lack of time and lack of resources. McLean suggests that an effective response to a crisis requires precise, timely and trusted information. Social media is far quicker platform compared to traditional mass communication channels. It is therefore considered to be number one choice when it comes to quick information sharing.

Bearing in mind that some airlines are heavily present on social media attracting millions of followers, social media again seem to be an ideal tool for handling crisis situations. Partly thanks to its global reach allowing for effective mass communication and also thanks to increasing numbers of people that follow airlines' social media sites for different reasons like complaining or simply seeking information.

The next part of the text is dedicated to best practices and lessons learnt from different airline crisis management cases that were handled through social media.

Asiana Flight 214 crash in SFO

Asiana Airlines flight 214 crash landed at San Francisco International Airport on July 6th, 2013. Krista Seiden, a Google employee had the unfortunate experience of watching it live. She immediately took a photo of it and hooked it up on Twitter. It took her an incredibly short 20-30 seconds since the moment the plane hit the ground. What happened in the next few moments could be described as social media madness.

In the next few moments there were many photos and news of the crash available on social media. Krista Seiden says that people kept asking her if it was real because none of the news channels were reporting anything yet.

This experience proves how instant the world of social media is. It is not hard to believe social media is the eyewitness news today.

Seiden continues that the most memorable and influential tweet of the day came from David Eun (@Eunner), a Samsung executive who reported the crash by saying "I just crash landed at SFO..." and tweeted a picture of the wreckage from only a few feet away.

Asiana Airlines updated its status a long 8 hours after the crash thanking people for their concern and support.

Even if there were no connected travelers at all, airlines simply have to react promptly. Prompt reaction from the airline side is even more important in the era of digital and mobile-internet passengers.

The case of Asiana shows that the crisis hit the airline as a big surprise and found the airline unprepared. It is impossible to completely prevent these situations from happening but it is surely possible to prepare for them. Airlines could be much better prepared if they incorporated their social media communication strategy into their crisis management procedures.

The airline could then prevent situations from happening in which a crash (or crisis) witness would be sharing incorrect information (like it was the case of Asiana flight 214). Krista Seiden who witnessed the crash shared incorrect information about origin airport of the flight. She shared Taipei as the airport of origin but the flight departed from Incheon International Airport near Seoul, South Korea. If the airline would have been present online it would have corrected the information.

The case of Asiana also shows that it is important to know where the information is shared. Given most of passengers aboard Asiana flight 214 were Chinese or Korean then it was most likely that the information was to be posted on major platforms in their home countries, like Weibo and WeChat. So the lesson to be learnt from this case is that a crisis needs to be communicated on the same channel as it is used by those who seek answers or just comment.

It is necessary for the airline to plan its crisis communication ahead of time. If the airline is able to act promptly (providing useful facts) it could prevent the airline brand from damage.

Airline best practices in driving customer service

Triple A case

Triple A case refers to “Ask AirAsia” – an online portal serving customers. The airline created the portal back in 2011 as a response to the growth of the airline routes network and increasing number of passengers’ queries. Another reason for creating it was to save money which would otherwise be needed for costly operations of the airline call center. The portal is operated as an interactive search engine of FAQs guided by Lil’ Miss Red. Customers can ask her questions. She answers by providing a menu of related questions to the question asked. Customers who haven’t found their answers here could go to social media (Twitter or Weibo) or they can be served immediately on Live Chat.

By introduction of Lil’ Miss Red Twitter and Weibo accounts, the airline was able to attract as much as 85,000 followers (on Twitter). The accounts have also proved to be excellent platforms for provision of customer support and assistance. By using the accounts the airline is much faster in response to passengers’ queries and it keeps its low-cost operations business objectives.

Airline best practices in driving revenue through social media

Jones (2013) says that making money by the use of social media is not proving to be very easy. Many airlines have already recognized that whatever it costs, they can't afford

not to play in the space - be it on Twitter, Facebook or LinkedIn.

He continues that anyone who joins the social throng must be prepared to constantly innovate. Dusting off "a great idea" from 2012 for another Facebook competition is exactly that: "so last year". And treating it as a hard-sell channel will be a guaranteed turn-off.

Many pay-offs airlines get from their social media presence are of intangible nature. For instance loyalty of passengers, ability to response to passengers’ queries quickly or ability to respond to criticism in the proactive way. Social media presence also helps airlines to reduce costs that would otherwise be invested in costly operations of customer care centers.

He also suggests that social media delivers airlines another, and simply the most dynamic - way to communicate with customers through every phase of their journey, from booking to arriving back home. Therefore opportunities that social media offer for revenue earning and up-selling should be literally endless, particularly if consumer data is harvested and put to good use. If airline social media presence is to deliver significant revenue the airline should view its social media activity as a marketing function, a public relations function as well as a sales channel.

Route launches with no money spent on traditional advertisements

Airlines usually spend a lot of money for advertising new routes. The money goes for TV or radio commercials or it is spent for billboard campaigns. Airlines usually ask for airport incentives as well. Incentives should cover initial advertising costs of a new route and they should also support operations to new destinations. Airports offer various marketing incentives for airlines in return for opening of a new destination: welcoming services when a new airline starts its operations at particular airport, press conference for inaugural flight of a new airline, promotion of a new route in airport magazine, advertising at various locations around the airport, commercial space on the airport website or even marketing materials in local language.

Some of the services are offered for free while some cost additional money. The following example of Virgin America shows how the airline promoted its new route using social media and did not spend on traditional advertising. The Toronto route-launch campaign was based on 50 % discount offered to first 500 fans who booked tickets using their Twitter account.

The airline applied similar approach when it announced the new Chicago-O'Hare to San Francisco and Los Angeles to San Francisco routes. The traveller paid \$7 and got a \$77 coupon that was good for round-trip airfare purchase of Virgin America's new routes on Groupon⁹. As the campaign turned to be a great success the airline repeated it for the Dallas-Fort Worth routes with minor changes to the price.

CONCLUSIONS

The above case studies show that airlines are able to manage crisis through social media to a great extent. The same applies to ability of airlines to drive revenues and customer care through social media. Airline presence on social media could even become a tool that would differentiate airline services. Especially when it seems that there is more convergence of business models of low-fare airlines and traditional carriers present nowadays.

Stefanik and Badanik (2010) suggest for example, that Air Berlin in 2005 (by that time considered to be a typical example of low-fare airline) commenced UK domestic services as feeders to its German services out of Stansted, introducing the network model elements of through pricing, ticketing and baggage. On the other hand several other traditional airlines have introduced paid catering on their short-haul flights and all now benefit from introducing internet sales and electronic ticketing. Many AEA (Association of European Airlines) member airlines have developed low-fare one-way pricing structures across their European networks. One member, Aer Lingus, has reinvented itself with an outright no-frills product on its European routes. Another, Brussels Airlines, has sealed a merger with former no frills carrier Virgin Express with a radically simplified two-tier pricing structure, offering flexible fares in one cabin and very low prices in the other. Another example of typically traditional airline (now part of Star Alliance) approaching market with price sensitive passengers is Austrian. Having introduced very competitive red ticket air fares the airline attracts substantial amount of passengers previously attracted by low-fare airlines only.

Side by side with a convergence of business models of traditional and low-fare airlines the passengers can exercise decrease in level of on-board services. Especially in terms of what kind of catering is (and used to be) bundled in the price of traditional airline air fare. Given, the comfort on-board aircraft (offered by traditional airline or a low-fare airline) is similar and differences between on-board services (offered

by both types of airlines) are not so significant the most important factor influencing passenger's choice of airline remains total trip costs.

At the time of connected travellers airline presence on social media could complement this criterion. It could become very important part of passenger's choice of airline. Simply because passengers would tend to buy more from an airline that helped them online and managed their queries through social media in a timely and efficient manner.

REFERENCES

- [1] 5 steps to successful crisis management for airlines. Available: <http://simpliflying.com/2010/infographic-five-steps-to-successful-crisis-management-for-airlines-in-the-age-of-social-media/> [2014, March 12]
- [2] Airline Business (April, 2013) "Cash boosters", Airline Business, p.56. Colchester: Business Reed Information Ltd. 2013.
- [3] Airline Business (March, 2013) "Social Awareness", Airline Business, p.54. Colchester: Business Reed Information Ltd. 2013.
- [4] Airline Business (March, 2014) "Social Awareness", Airline Business, p.37. Colchester: Business Reed Information Ltd. 2014.
- [5] Airlines in Social Media: Case studies featuring six airline brands conquering the space, SimpliFlying, Available: <http://simpliflying.com/wp-content/uploads/Compiled-v9.pdf> [2014, March 3]
- [6] Best airlines driving customer service and crisis management through social media. Available: <http://www.slideshare.net/shanzx/best-airlines-driving-customer-service-crisis-management-through-social-media> [2014, March 08]
- [7] Creaton Siobhán. Ryanair: How a Small Irish Airline Conquered Europe. London: Aurum Press Ltd., 2004.
- [8] Evans, Liana. Social Media Marketing: Strategies for Engaging in Facebook, Twitter & Other Social Media. USA: Que publishing, 2010.
- [9] Hvaas Anders Kristian and Munar Ana Maria. "Let's be social at 30.000 feet!". Available: <http://aerlinesmagazine.wordpress.com/2011/01/30/lets-be-social-at-30000-feet/> [2014, February 12]
- [10] Impact of social media on hospitality and tourism. Available: <http://www.slideshare.net/MindShiftInteractive/mindsh>

⁹ Groupon (derived from "group coupon") is a deal-of-the-day website that features discounted gift certificates usable at local or national companies.

ift-interactive-social-media-report-2012 [2014, January 21]

- [11] Jones, Kingsley Max. ANALYSIS: How many airlines are making money from social media? London: Airline Business, 2013. Available: <http://www.flightglobal.com/news/articles/analysis-how-many-airlines-are-making-money-from-social-382548/> [2014, March 02]
- [12] Kahonge Maureen. The Importance of Social media in today's airline business. Available: <http://www.afraa.org/index.php/media-center/publications/articles-a-research-papers/2013-articles-and-research-papers/413-the-importance-of-social-media-in-todays-airline-business-by-maureen-kahonge/file> [2014, January 21]
- [13] Manzo Mary. Why Airlines Are Cruising on Social Media. Posted on November 29, 2011. Available: <http://socialmediatoday.com/marymanzo/397935/why-airlines-are-cruising-social-media> [2014, March 1]
- [14] McLean, Hamish. The world is watching Malaysia Airlines: lessons in crisis management. Monday, 10 March 2014
Available: <http://www.smartcompany.com.au/leadership/strategy/41132-the-world-is-watching-malaysia-airlines-lessons-in-crisis-management-.html> [2014, March 10]
- [15] Nigan Shashank. 6 steps to building a swashbuckling airline brand. Available: http://www.brandchannel.com/images/papers/428_Airline_Branding.pdf [2014, May 28]
- [16] Sample benchmark report airline marketing. Available: http://www.airlinetrends.com/wp-content/uploads/2013/12/AirlineMarketingBenchmark_SAMPLE_dec2013.pdf [2014, March 08]
- [17] Serusi, Marco. Top 10 Crisis Management Case Studies: How Social Media Can Help Airlines Deal With Their Worst Nightmares. Available: <http://simpliflying.com/2012/top-10-crisis-management-case-studies-how-social-media-can-help-airlines-deal-with-their-worst-nightmares/> [2014, February 20]
- [18] Social Media Analytics: Which airline is flying high in social? Available: <http://www.sprinklr.com/social-scale-blog/social-media-analytics-best-airlines-in-social-media/> [2014, March 17]
- [19] Stefanik Milan, Fasih A. Hitham, Badanik Benedikt. Untapped potential of on-board advertising (published at the third international conference on research in air transportation ICRAT 2008, page 392)
- [20] The Best Airlines Driving Revenue through Social Media. (2011) Available: <http://www.slideshare.net/shanxz/the-best-airlines-driving-revenue-through-social-media> [2014, March 11]
- [21] The state of airport marketing. Available: <http://simpliflying.com/2013/free-report-the-state-of-airport-marketing-7-key-trends-case-studies/> [2014, May 04]
- [22] The world's 10 most innovative airlines. Available: http://www.airlinetrends.com/wp-content/uploads/2012/06/Innovative_Airlines_2012-airlinetrends.pdf [2014, May 01]
- [23] Thomas, Alex. Special report: Social media as more than a tool for marketing. Available: <http://www.flightglobal.com/news/articles/special-report-social-media-as-more-than-a-tool-for-368498/> [2014, February 10]

ACKNOWLEDGEMENT

This paper has been created following the project in the process of solution which has been co-financed by the EU sources entitled „ Centre of Excellence for Air Transport Centrum- ITMS 26220120065.“



AUTHOR INFORMATION

Benedikt Badánik, Associate professor, Air Transport Department, University of Žilina, Slovakia

INNOVATIVE APPROACH IN PROVISION OF AIR NAVIGATION SERVICES IN EUROPE

Ing. Miroslav Bartoš

LPS SR, š.p.

Air Transport Department, University of Žilina, Slovakia

miroslav.bartos@lps.sk

Assoc. prof. Benedikt Badánik, PhD.

Air Transport Department, University of Žilina, Slovakia

benedikt.badanik@fpedas.uniza.sk

Abstract - Provision of air navigation services is one of three main pillars of aviation business. Air navigation service providers, together with airlines and airports, contribute significantly to seamlessness of air transportation. EUROCONTROL indicates that there will be 14.4 million flights by 2035 handled in Europe, 50% more than in 2012. Air traffic growth will put a strain on ATM capacity and exacerbate the misalignment between ATM capacity and airport throughput where nearly two million flights would not be accommodated because of airport capacity shortfalls. The article will focus on description of technological, service provision and regulatory framework of future provision of air navigation services in Europe.

Key words - air navigation services, ATM capacity, airlines, airports

BACKGROUND

Provision of air navigation services is one of three main pillars of aviation business. Air navigation service providers, together with airlines and airports, contribute significantly to seamlessness of air transportation. The latest EUROCONTROL forecast indicates that there will be 14.4 million flights by 2035 handled in Europe, 50% more than in 2012. Air traffic growth will put a strain on ATM capacity and exacerbate the misalignment between ATM capacity and airport throughput where nearly two million flights would not be accommodated because of airport capacity shortfalls. The synergies and cooperation are more than necessary to be able to provide high-quality on-time service for a reasonable price for the main customer – the passenger.

Historically, air navigation service providers have been established as the natural monopolies and entities responsible for safety in aviation. Of course, this is still their primary role, but there are some other aspects affecting overall performance of air navigation services providers – costs, ATFM delays and environmental issues. Every category is assessed separately by Performance Review Commission (PRC). The performance scheme is the key enabler for measuring the achievements. Based on a system of target setting, planning, monitoring and reporting in the four key performance areas of safety, environment, capacity and cost-efficiency, the performance scheme establishes the framework under which service providers are compelled to change in order to provide better services at lower costs. For example the cost targets effectively set a price cap on the services, above which the service providers may not charge users, thus forcing them to be more cost-effective. And this is the real challenge.

CURRENT CHALLENGES IN PROVISION OF AIR NAVIGATION SERVICES IN EUROPE

ANSPs operate in a complex environment. In the short-term and mid-term time horizon, ANSPs will have to face three key challenges to be able to increase performance and achieve the EU targets for RP2 – safety RAT delays 0,1 min per flight, cost-efficiency -3,2%, CO2 emissions 4,4%/2,75% (planned trajectory/real trajectory):

Efficiency/Cost-cutting/ATCO vs non-ATCO ratio

As the setting of service unit rate does not allow increasing (except extremely crisis scenario not caused by everyday business of the ANSP, but external and unpredictable effects), providers have to focus on enhancement of their own macro/micromanagement and on seeking new sources of income. And this is completely new role introducing unique challenges.

Defragmentation

Having in mind that the ANSPs costs generate only 6 - 8% (IATA, „Profitability and the air transport value chain,” June 2013) of all costs in aviation segment, significant changes need to be implemented in a bigger airspace than in a national or a local one to gain the real benefits. The 20 years discussion about Single European Sky does not bring any tangible results at all.

Regulation

Regulation helps ANSPs to cope up with the main rules and principles ensuring safe and seamless flow of air traffic. But if the regulation affects areas like macro and micromanagement, investments, company organisational structures, employees' mobility, social dialog etc., it can prevent companies from achieving the defined targets.

Every authority in ATM segment knows that something needs to be done to be able to handle the traffic safely and meet the targets mentioned above. Working on various projects (SES, FABs, SESAR, NextGen...) in the different political and legal conditions brings out several ways of solving the situation. But choosing any of them means being a pioneer and introducing innovative solutions supported by the revolutionary technology with impact on the social dialog.

NEW APPROACH TO PROVISION OF AIR NAVIGATION SERVICES IN EUROPE

Is it possible to meet all the requirements and targets set up by different world and European entities (ICAO, European Parliament, European Commission, European Aviation Safety Agency, FABs and state level) without any systematic changes at all? Are we ready to change our mind-setting and apply free market principles to the ATM business or rather to stick to the national ANS provision and focus on the harmonization? Is the industry and infrastructure ready to absorb these changes with any negative impact on the four main European targets? Are the legal and political systems

of the states prepared for such changes? Are these expectations realistic? Do ANSPs have solid scenario how to improve performance?

Air traffic in Europe is expected to more than double in the next 20 years and even triple in some regions. However, the equipment used to manage the traffic flows has changed little over the past decades and it is struggling to keep up with developments. The European Commission states that the reliability and safety rates for air transport, if maintained, require a qualitative leap for the future as the capacity limit becomes critical.

The Commission says, current air traffic control systems are close to becoming obsolete and are ill-suited for the rapid, economic and reliable development of aviation in Europe, particularly as expectations have changed in:

- institutional frameworks
- airspace organisation
- navigation criteria
- system and technologies
- ground infrastructure
- equipage requirements for aircraft
- certification and approval processes
- civil/military cooperation

Therefore a new approach to provision of air navigation services cannot be based on the current system - the technology is outdated and does not enable air traffic to be managed in an optimal way. As a result, aircraft are forced to follow predefined flight paths rather than flight paths that are optimal in terms of energy consumption and noise. If no proactive steps are taken to better manage increasing traffic density, the cost of air transport and the various risks associated with it will rise.

The following comparison suggests main differences between major world regions in provision of ATM services. It uses benchmarking model developed by FAA and EUROCONTROL on behalf of EU.

Table 1 US/Europe ATM key system differences
(Source: compiled by the author from different sources)

Calendar year 2013	Europe	USA	US vs. Europe
Geographic Area (million km2)	11,5	10,4	-10%
Nr. of civil en route Air Navigation Service Providers	38	1	
Number of Air Traffic Controllers (ATCOs in Ops.)	17200	13400	-22%
Number of OJT/developmental ATCOs	1000	1740	+74%
Total ATCOs in OPS plus OJT/developmental	18200	15140	-17%
Total staff	58000	35500	-39%
Controlled flights (IFR) (million)	9,6	15,1	+57%
Flight hours controlled (million)	14,3	22,4	+57%
Relative density (flight hours per km2)	1,2	2,2	x1,7
Share of flights to or from top 34 airports	67%	66%	
Share of General Aviation	3,9%	21%	
Average length of flight (within respective airspace)	551 NM	515 NM	-7%
Number of en route centres	63	20	-43
Number of APP units (Europe) and terminal facilities (US)	260	163	-97
Number of airports with ATC services	425	516	+91
Of which are slot controlled	>90	4	
Source	ECTL	FAA/ATO	

Table 2 US/EUROPE cost-efficiency comparison
(Source: compiled by the author from different sources)

Cost-efficiency	European ANSP	US FAA
Air Traffic Controller (ATCO) - hour productivity (in flight hours per ATCO-hour)	0,77	1,01
ATCO employment costs per ATCO - hour (in €)	96	72
ATCO employment costs per composite flight hour (in €)	125	71
Total costs per composite flight hour (in €)	419	321

Based on the statistics, the European model of provision of the air navigation services is about 23% more expensive than the FAA structure by ensuring the same level of safety standards. Having in mind the costs-effectiveness as a key target assessed by EC, than cost-cutting has to be at least 23% or more to gain a business model delivering the same or better performance in terms of US/Europe cost effectiveness comparison.

The EC cost reduction target for RP2 (2015 – 2019) -3,2%. Achieving this target by any European ANSP is considered as fully compliant to the EC Performance Plan.

The main assumptions of the Performance Plan are:

- traffic growth approximately 3% according to the STATFOR
- following the regulation of EU in terms of RP1, RP2
- cost reduction approximately -3,2% in the next 3 years
- maintaining the same safety level/or higher
- maintaining the same level of delays/or lower

After 12 years of implementation of SES (SES in 2004, SES II in 2009, SES II+ in 2016) we have seen many changes. ANSPs are very engaged at all levels:

SES, SES II, SESII+

Single European Sky – the European project of establishing one seamless, cheaper, more flexible airspace with more capacity, less delays and one air navigation service provider.

SESAR, SESAR JU

Single European Sky ATM Research (SESAR) project (formerly known as SESAME) is the European air traffic control infrastructure modernisation programme. SESAR aims at developing the new generation air traffic management (ATM) system capable of ensuring the safety and fluidity of air transport worldwide over the next 30 years.

Functional Airspace Blocks

The establishment and subsequent implementation of FABs shall be achieved by a mutual agreement by all the Member States and, where appropriate third countries who have responsibility for any part of the airspace included in the functional airspace block. It is important that the FAB agreement is built on a solid legal basis and creates an appropriate legal umbrella further allowing for effective and

efficient cooperation between the various entities in a FAB, including room for a certain flexibility of FAB stakeholders.

Centralised services

With new systems being developed and introduced over the next decade, several of the services for handling data could be implemented centrally, rather than at a national level. This would reduce the costs resulting from overlapping investments, improve performance, improve the level of interoperability and help putting Europe at the cutting edge of ATM technology

European Aviation Safety Agency

Organisation responsible for the highest common level of safety protection for EU citizens, the highest common level of environmental protection, single regulatory and certification process among Member States, Facilitate the internal aviation single market and create a level playing field and work with other international aviation organisations and regulators.

Performance scheme

Commission regulation (EC) No 390/2013 of 3rd May 2013 laying down a performance scheme for air navigation service and network functions. The Commission has published the EU-Wide performance targets for RP2: 2015-2019 in the Official Journal of the European Union. By 1 July 2014 FABs/ Member States have submitted their Performance Plans to the Commission.

Network Manager

The primary objective of the Network Manager is to improve the performance of the European aviation network.

Deployment Manager

The SESAR Deployment Manager is the official title of the organisation that is coordinating the upgrading of Europe's air traffic management infrastructure. The main task of the SESAR Deployment Manager is to develop, propose and maintain the Deployment Programme of SESAR concepts and technologies and ensure efficient synchronisation and overall coordination of implementation projects, as well as the related investments in line with the Deployment Programme.

CONCLUSIONS

There are major differences in the institutional and legal framework for the provision of ATS in the individual European States affecting the governance and ownership of ANSPs. We can find here traditional, corporatised and privatised model. Many member states still understand ATC as a sovereignty issue. SES as a whole, and ANSPs

individually, can realistically only achieve what is enabled and supported by states. The development of the next steps for SES should be based on a realistic analysis of the performance of the European ATM network and its future needs, taking into account the institutional, legal and societal framework.

Technological framework

The current ATM infrastructure is highly fragmented and disparate, which results in unnecessary costs and operational limitations. How should the future ground ATM infrastructure in particular ATM systems be harmonised, based on European standards, open source and modular systems, common ATM system architecture, common support services and common procedures, in order to ensure the desirable level of capability, reliability, interoperability and upgradeability at minimum cost? How should this harmonization be achieved?

Many initiatives (Eurocontrol, SESAR, etc.) are addressing interoperability between various “national” systems (e.g. PENS, ARTAS, etc.). Since the introduction of SES, ANSPs have significantly increased their collaboration with each other, as well as with social partners, civil and military airspace users, airports and with the air transport industry in general. Within the SESAR and ICAO strategies and master plans, the ANSPs and their industry partners are cooperating to develop, implement and monitor up-to-date interoperable new technologies and systems, shaping the future global gate-to-gate and ground-to-air aeronautical infrastructure. In addition, we are witnessing already now new de-facto standards both in CNS and in ATM. Nav-aids, radios and radars are becoming more and more similar. And if we look at international partnerships as COOPANS, CoFlight, iTEC, etc. they internally are the beginning of standardization in ATM.

New solutions are being developed by all industry stakeholders working in collaboration through the SESAR programme. The link between R&D and deployment is provided by the European ATM Master Plan. The R&D programme is driven by performance needs with the transition of solutions from R&D to deployment based on clear and compelling CBAs endorsed by the airspace users, airports and ANSPs for synchronised deployments. This will ensure a performance oriented approach to the ATM infrastructure lifecycle.

Service provision framework

It is important to differentiate between FABs – requiring State involvement – and other forms of cooperation among ANSPs. These are complimentary to each other. Member States and their ANSPs just recently have formally established FABs based on the SES 2 legislation. The regulatory efforts of the European Commission should focus on creating the legal and institutional conditions of cooperation between ANSPs, and on the abolition of barriers which hinder cooperation – such as liability issues, common charging models, interoperability etc. No specific EU-

regulation is felt to be necessary for the realisation of industrial partnerships in ATM. Of course the general regulations concerning procurement, market and antitrust rules have to apply. The relationship between ANSPs and the supplying industries should be governed by good customer-supplier relationship management based on the requirements of the customer. And this could be the starting point to think about new approach of the provision of air navigation services.

What initiatives would foster the improved performance of European aviation network? Generally, network capacity is sufficient and ATC related delays in most areas are at a very low level. There should be the expansion of the scope of the network manager to include those network services which directly relate to the Network Manager’s operations and which provide sufficient performance benefits and cost savings. However, expanding the scope of the Network Manager must not duplicate or conflict with the responsibilities of ANSPs, the SESAR Joint Undertaking and the future Deployment Manager.

Regulatory framework

Today, economic and technical regulations are quite important. If part of ANS is opened for competition, there would be a need to revise economic regulation. While normal competition rules should apply to the part of ANS opened to the market, economic regulation should be reduced and evolved to cover remaining ANS monopolies. How can the principles of better regulation of ANSPs be applied?

It is important to be clear why regulation is needed in the first place. Citizens expect their governments to ensure their safety and welfare. Businesses expect public authorities to ensure a level playing field and boost competitiveness. Regulation is key to meeting these challenges.

The way of provision of air navigation services is the main issue on different European levels in terms of cost-cutting and on-time operation. To find an appropriate model of air navigation services provision one needs to answer the question: How will the provision of air navigation services look like? And what impact will it have on the passenger? Is the FAB approach consistent with the development of Industrial partnership? How can it be improved?

Based on the existing regulation and the latest development in the field of ATM, sooner or later the operational concept for provision of air navigation services will need to change. The traffic growth, safety standards and cost-cutting cannot be handled with the same isolated national approach like 20 years ago. That is why the new approach in provision of air navigation services must be implemented.

REFERENCES

- [1] EUROCONTROL, „EUROCONTROL Seven-Year Forecast,” Brussels, February 2015

- [2] PERFORMANCE REVIEW BODY OF SINGLE EUROPEAN SKY, „PRB assessment of the revised performance targets for RP1,” Brussels, April 2012
- [3] HELIOS TECHNOLOGY Ltd., „ATM cost-efficiency targets,” Farnborough, July 2013
- [4] PERFORMANCE REVIEW BODY OF SINGLE EUROPEAN SKY, „Union wide targets for the 2nd Reference period of the Single European Sky Performance Scheme,” Brussels, May 2013
- [5] LPS SR, š.p., „Local Single Sky Implementation Slovakia,” Bratislava, March 2015
- [6] EUROCONTROL, „Risk Analysis Tool,” Brussels, December 2015
- [7] IATA, „Profitability and the air transport value chain,” June 2013
- [8] ICAO, „Global Air Transport Outlook to 2030 and Trends to 2040,” Montreal, September 2013
- [9] FAA/EUROCONTROL, „Comparison of Air Traffic Management-Related Operational Performance: U.S./Europe,” June 2014
- [10] EUROCONTROL, „Hybrid control in air traffic management systems,” Decision and Control, 1995
- [11] <http://www.nats.co.uk/library/history1.html> [Accessed 11 March 2015]
- [12] <http://www.eurocontrol.int/dossiers/fabs> [Accessed 26 March 2015]
- [13] http://ec.europa.eu/transport/modes/air/ses/ses-award/projects/coopans-alliance_en.htm [Accessed 2 June 2016]
- [14] <http://www.naviair.dk/coopans> [Accessed 15 January 2016]
- [15] <http://www.indracompany.com/en/noticia/european-atm-collaboration-itec-formally-extended> [Accessed 3 March 2016]
- [16] <http://www.developpement-durable.gouv.fr/IMG/pdf/4-Flight.pdf> [Accessed 3 September 2015]
- [17] <https://www.thalesgroup.com/en/worldwide/aerospace/press-release/coflight-programme-reaches-v2-speed> [Accessed 22 May 2016]
- [18] http://ec.europa.eu/transport/modes/air/ses/ses-award/projects/fra_en.htm [Accessed 21 November 2015]
- [19] <http://www.borealis.aero/Home.19.aspx> [Accessed 19 April 2016]
- [20] <http://www.nats.aero/news/a6-alliance-widens-sesar-collaboration-to-include-switzerlands-skyguide/p://www.a6alliance.net/> [Accessed 03 August 2016]
- [21] <http://www.nats.aero/news/a6-alliance-widens-sesar-collaboration-to-include-switzerlands-skyguide/> [Accessed 17 April 2016]
- [22] <http://www.gateone.aero/> [Accessed 15 January 2016]
- [23] http://ec.europa.eu/transport/modes/air/single_european_sky/doc/ses2plus/facts-and-figures [Accessed 9 October 2015]

AUTHOR INFORMATION

Miroslav Bartoš, Chief Executive Officer, Letové prevádzkové služby SR, š.p. (Slovak ANSP), PhD. student Air Transport Department, University of Žilina, Slovakia

ASPECTS OF FLIGHT CREW FATIGUE

Ing. Andrea Brezoňáková

Air transport department, University of Žilina, Slovakia

ada.brezonak@gmail.com

Assoc. prof. Benedikt Badánik, PhD.

Air Transport Department, University of Žilina, Slovakia

benedikt.badanik@fpedas.uniza.sk

Abstract - British low cost airline easyJet grew from its establishment in 1995 from a virtual airline into a large airline operating out of 26 bases and employing about 10.000 personnel. The airline expansion came along with many challenges, such as maximum utilisation of the crews. Their workload turned into a high fatigue risk level and was calling after an action in order to maintain good safety standards. Captain Simon Stewart conducted a fatigue study where he looked thoroughly at the impact on the pilot's performance when working on six consecutive days by using Juran's "Breakthrough and Control" and Six Sigma methods. It was proven that a work pattern of maximum five consecutive days brings along benefits in everyday operations by reducing fatigue risk and improving the overall effectivity of the crews. The paper presents experience of European airlines with implementation of FRMS - Fatigue Risk Management System that deals appropriately with fatigue of their crews. Fatigue reports will be examined in the article with a view to prove their large contribution to the legal knowledge, as actual airline operation might find the difference between being "paper safe" and the "actual safety".

Key words - fatigue, easyJet, low cost carriers, working pattern, roster, Fatigue Risk Management System, flight safety monitoring, fatigue reporting

INTRODUCTION

British low cost airline easyJet had a long path since its establishment in 1995. In its beginnings, it served one base, leased two airplanes and basically, it was a virtual airline. In 2008, it recorded an airline operating out of 20 bases on 170 aircrafts and employing about 7000 employees. By today, easyJet operates within two aircraft operator's certificates (British and Swiss) out of 26 bases and employs about 10.000 personnel. Obviously, it became one of the largest low cost airlines that operate within the European continent.

The progress came along with many challenges and factors determining operation of a low cost airline, such as intensive

scheduling and maximum utilisation of the crews. The crew workload turned into high fatigue risk levels by operating on high duty hours, multiple leg days on consecutive basis. Captain Simon Stewart looked at the problematics thoroughly in his post-graduate fatigue study, altogether with sleep, fatigue and shiftwork specialist Alexandra Holmes, PhD. from Clockwork Research.

BACKGROUND TO THE RESEARCH AT EASYJET

Fatigue as per ICAO is defined as: "A physiological state of reduced mental or physical performance capability resulting from sleep loss or extended wakefulness, circadian phase, or workload that can impair crew member's alertness and ability to safely operate an aircraft or perform safety related duties."

Also, research study from IATA defines following factors that may affect crew fatigue (Stewart, HILAS, 2009):

- increased flying hours
- unsymphatetic rostering practices
- absence of adequate JAA/EU rules on FTL

These factors may be further influenced by:

- Shortage of experienced pilots
- high utilisation rates of crews
- lack of operations/administration support

And compounded by:

- the company organisational or corporate culture
- the crew professional culture

Fatigue is a phenomenom, a mental or physical state of mind that cannot be quantitatively measured as there are way too many factors affecting fatigue. The main source considered to be a cause is the roster design. However, it is being influenced by the company's bussiness model, seasonal demand, adopted FTL scheme and external influences. It

also needs to reflect fatigue promoting issues, such as long duty days, time of start of the duty and duties transitions.

The company’s environment affects the roster design the employee has to work in. Further, there are some individual factors, such as age, sleep demand, the ability to sleep in variable times of a day. Individual’s lifestyle, such as having young children, second jobs, commute, social engagements or domestic disharmony, greatly interacts with the roster and may contribute to fatigue level.

When on duty, all these factors merge with operational influences and will further interact with the on-the-day issues, namely with the “hassle” factors and environmental variabilities.

EasyJet focuses on professionalism, training and crew member health in order to deliver a safe standard in its everyday operation. However, maximum utilisation of crews reflected some scheduling methods that needed to be revised. It was experienced that the prescriptive regulation was not enough. FTL schemes restrict commercial and safety flexibility by limiting scope for effective crew utilisation, providing limited feedback on safety threats and by giving the assumed protections of being “legal”. However, FTL schemes are a form of static safety managements and they do not consider the sleep opportunity and sleep quality in relation to the circadian influence, crew individuals and crew differences, sector workload and hassle factors (Stewart, HILAS 2009).

In April 2005, easyJet was granted the alleviation from FTL by the UK CAA. It was based on the results of a safety case report of a six month roster trial. The trialled roster composed of 5/2/5/4 pattern with five early duties, two days off, five late duties, four days off and replaced the original 6/3 roster combined of three early duties, three late duties and three days off. The derogation from the FTL (CAP 371) and its subsequent approval was required because of the three consecutive days off limit exceedance.

THE SIX-SIGMA METHOD

The philosophy of Six-Sigma is a methodology that places an emphasis on data-driven analysis through the use of a diverse collection of tools to identify and address the sources of risk within the process (Stewart, HILAS 2009).

The methodology is composed of five elements - Define, Measure, Analyse, Improve and Control. The process is executed by defining the problem, deliverables, measures and measurement system first. Once the measurement system is in place, it needs to work with the prescribed criteria. Statistical and analytical tools aim to identify the issues, collect and analyse the data. Six-Sigma method represents a project orientated approach to a systemic problem and aims to improve the overall system functionability. Finally, results are being implemented into the daily operations.

The methodology is composed of five elements - Define, Measure, Analyse, Improve and Control. The process is executed by defining the problem, deliverables, measures and measurement system first. Once the measurement system is in place, it needs to work with the prescribed criteria.

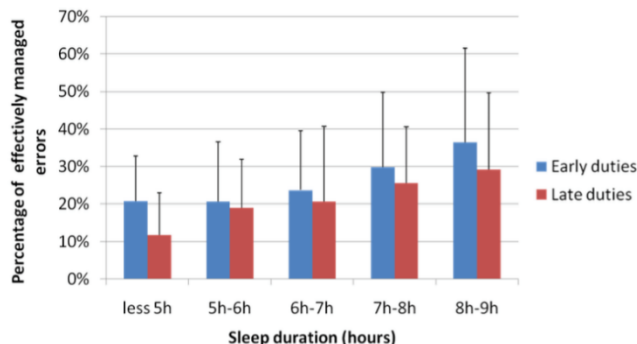

Figure 1 Effectively managed errors in relation to sleep duration

Statistical and analytical tools aim to identify the issues, collect and analyse the data. Six-Sigma method represents a project orientated approach to a systemic problem and aims to improve the overall system functionability. Finally, results are being implemented into the daily operations.

THE ROSTER TRIAL

The Six-Sigma model served to identify operational risk areas and improper rostering practices while under current schedule process. The main goal was to re-design the rosters towards a better quality output and remove fatigue related risks where applicable. A post-evaluation of the 6/3 roster nominated an amended roster design of 5/2/5/4. The reduction of working week from six to five days was predicting a reduction of fatigue and increasing time off while on the transition from early to late duties, supposing that a “slow wave” duty pattern would minimise the circadian disruption throughout the roster period. Also that the cumulative effects of the new roster pattern should be reduced. A review of crew performance on selected duty days allows evaluation throughout the regular schedule pattern. The study was also looking for correlation between crew fatigue levels as a function of rostered day, “early” or “late” slow wave duty, sector number and crew performance by using the University of Texas Threat and Error Management Model.

Results of the study proved the hypothetical assumptions - a 5/2/5/4 pattern showed reduced fatigue risk in comparison to the 6/3 schedule pattern and an overall of 50% improvement in crew performance, where mean error rates reduced from 5.2 to 2.6 of the total crew errors against a duty day. There was no significant difference found in performance between the “early” or “late” shift weeks and between the duty days. However, the amended duty pattern shows less impact on crew circadian rhythms and consistent performance throughout the schedule.

Threat management on the 6/3 roster pattern reflected some fluctuation - from poor performance of 67% on the first duty day towards the improvement on the third “early” duty and a downfall to 78% on the sixth duty day. Rather than superior was the threat management on the 5/2/5/4 roster pattern where it remained at an average of 96% with no evidence of cumulative fatigue effects on performance.

The performance of the new proposed 5/2/5/4 roster pattern was monitored and included:

- Line Operations and Safety Audit
- Predictive fatigue modelling
- Demographic, CRM and Attitude surveys of the pilot population
- Activity watches and Sleep diaries study
- Table 1 The fatigue indicators overlook
- PC based cognitive performance testing
- Rostering and scheduling information
- Archive data - Air Safety Reports
- Flight Data Monitoring and safety data analysis
- Archive Crew Duty hours, Archive Crew Sickness rate, Archive crew turnover rates
- Roster stability data

BALPA, the British Airline Pilots Association, was the recognised union through which any changes to crew terms and conditions had to be negotiated. The proposed 5/2/5/4 pattern was subject to vote after the UK CAA approval and before the pattern could be implemented across the company network. Among the 65% members who took part, the new schedule pattern gained 93% approval rating. Seven lifestyle questions were directed to the crew members to compare between both roster patterns. The 5/2/5/4 pattern gained the most of the votes in six questions:

- Q1. Which pattern enables a better work/life balance? (77%)
- Q2. Which pattern enables you to get more sleep? (74%)
- Q3. Which pattern do you feel less tired/fatigued on? (91%)
- Q5. Which pattern do you feel more alert on? (84%)
- Q6. Which pattern enables a more regular sleep pattern? (91%)
- Q7. Which pattern enables you to perform more safely at work? (84%)

Fatigue indicators	April	Previous month	3 month	12 month
Commute	8%	7%	5%	6%
Delay(s)	31%	21%	24%	27%
Early start time	8%	38%	22%	28%
Early to Late transition	8%	21%	14%	10%
Health	8%	10%	8%	7%
Home issues	8%	10%	12%	17%
Home rest	31%	14%	23%	24%
Hotel rest	38%	17%	20%	12%
Insufficient rostered rest time	31%	24%	28%	26%
Late finish	38%	28%	32%	29%
Late to early transition	8%	0%	3%	4%
Long duty day	54%	55%	59%	54%
Long-term fatigue	23%	31%	20%	16%
Positioning	8%	21%	16%	9%
Roster disruption	38%	24%	26%	23%

BREAKTHROUGH AND CONTROL

Juran's Breakthrough and Control is a management system that represents producing ideal product features and minimum deficiencies at lowest possible cost in three basic tasks. Initially, the management sets the strategic and operational goals, including the the financial and quality planning. Second step leads to prevention and correction of the "bad" change - it is known as control. The control consists of measuring actual performance in comparison to the standards or requirements that were set during the planning process. The target of second step is stability. Last task, the breakthrough represents creating of a "good" change. It is a deliberate change towards higher levels of organisational performance that is already being maintained by the control.

Applied to the easyJet study case, the study resulted in a change of corporate attitude and establishment of management system elements for the oversight of fatigue risk supported by a just safety culture (Stewart, 2009). Based on confidentiality and non-punitive reporting, new safety data protocols had to be established. An analysis with the results of the study had been presented to the stakeholders. The study represented a trigger response by the operator to multiple fatigue related signals into the management group by presenting an overlook of crew performance and historical analysis of incident and leading to the concept of improvement breakthrough. The initial results caused the management to review the adequacy of current fatigue codified controls in relation to the risk oversight requirements of the low cost carrier business model. A managerial approach to fatigue related risk manifestation had to be adapted and led to a process redesign as a new method of an "acceptable means of compliance". Also, a control process to monitor fatigue related risks had to be established. It meant an actual step beyond the planning, control and breakthrough control (Stewart, 2009).

FATIGUE RISK MANAGEMENT SYSTEM SET UP

Components of SMS (Safety Management System) are:

- Safety Policy and Objectives
- Safety Risk Management
- Safety Assurance
- Safety Promotion

FRMS is an essential part of the SMS and represents as defined by ICAO: "A data-driven means of continuously monitoring and managing fatigue-related safety risks, based upon scientific principles and knowledge as well as operational experience that aims to ensure relevant personnel are performing at adequate levels of alertness." (ICAO, 2011)

The FRMS according to the ICAO draft document:

- Should be an integral part of an established SMS (Safety Monitoring System)
- Applies SMS principles and processes to proactively identify and continuously manage fatigue safety risk
- Functions within a regulatory oversight framework
- Can enhance safety within the envelope of prescriptive flight/duty time limits

ICAO also formed a Fatigue Risk Management subcommittee inclusive of easyJet. The goal was a FRMS set up as a next step to the flight time, flight duty time, duty time and rest periods amendment proposals for the amendment of Annex 6, Part I. The guidance developed included(Stewart, 2009):

- Guidance for the development of FRMS
- Flight time, flight duty periods and rest periods for fatigue management
- Fatigue Risk Management Concepts and definitions
- Essential components of an FRMS
- Roles and responsibilities of operators, employees and regulators
- Guidance for development of fatigue risk management regulation
- Guidance on FRMS education and awareness training

EasyJet adapted the FRMS to manage operational challenges of flight and duty time limitations and rest requirements and by acknowledging the FRMS framework a developing a fatigue safety performance model.

Causal factors of fatigue will vary individually - there might be high workload combined with intensive short-haul scheduling and sleep deprivation which is a typical occurrence at low cost airlines operations. Scheduling factors, circadian disruption, sleep deprivation and extended duty periods can also affect crew alertness and performance. Another contributing factors are inadequate restorative sleep, environment, commute time, individual factors, work factors and family obligations. All the antecedents of fatigue are linked to sleep deprivation but sleep deprivation is both a cause and a consequence of fatigue (Stewart, 2009).

Searching for the adequate risk management model to be applied at easyJet, the SIRA framework has been established. System Integrated Risk Assessment (SIRA) acts in a proactive manner. A range of event inputs merges with a "system sensory net" that gathers technical, human performance and system data. These are put into an intelligence process where causal patterns are being classified and analysed. The cycle continues into decision making, intervention design, risk mitigation and monitoring. The model allowed to be applied after a wide range of evidence was collected over an extended period, including basic technical and human performance input, company tailored surveys and in-flight performance measures. All data were analysed by a fatigue and rostering model that identified vulnerable areas in regards to human circadian periodicity and high risk areas. Following, the roster had to be redesigned and the new schedule was required to be

monitored. The adjusted roster pattern gained popularity within the flight crews and conveyed greater operability to the airline. Generally, the roster optimisation contributed to the lower risk of cumulative limits being a constraint, less reserve days to compensate for disruptions, increased productivity, lower sickness rates and higher retention rates (Derbyshire).

FRMS is subject to the variable nature of fatigue risks. There are areas that are considered to be more challenging, such as cumulative fatigue, individual differences, sector workload, complacency but also the difference between the flight deck and cabin working environment.

CONCLUSION

British low cost airline easyJet had a long path since its establishment in 1995. It served one base, leased two airplanes and was basically a virtual airline. A few years later on, in 2008, it recorded an airline operating out of 20 bases on 170 aircrafts and employing about 7000 employees. The progress came along with many challenges, such as utilisation of the crews who suffered under fatigue. Thanks to Captain Simon Stewart who conducted a fatigue study, easyJet became an airline convenient to the crew rostering. The study contributed to the knowledge of fatigue risks within low cost carriers operations as previous regulations (CAP 371) have been primarily designed around long haul operations and do not reflect the operations characteristic for low cost airlines.

There has not been an adequate number of fatigue research at low cost carriers, easyJet being an extraordinary. It is caused by many factors, mainly as of the low cost carriers operations characteristics and company culture.

The study comprised a long-term process with multiple steps and methodologies in consideration. The outcome led to an enhanced comprehension of fatigue risk, roster improvement and Fatigue Risk Management System introduction that was based on non-punitive reporting and just culture principles. EasyJet went beyond the planning, control and breakthrough process by establishing FRMS - Fatigue Risk Management

System that helps to mitigate fatigue of their crews. The key was to differentiate between the FTL and FRMS and the proper set up of the fatigue reporting system. Also, using experience of fatigue reports largely contributes to the legal knowledge, as actual airline operation might find the difference between being “paper safe” and the “actual safety”.

However, the study was based on the prescriptive rules of CAA CAP371 that transitioned to the EASA rules start of 2016. The transition combined with high market demand on flight crew brought along repeatedly the fatigue issue that needs to be resolved in order to meet the future company plans.

REFERENCES

- [1] Fatigue Risk Management Systems. Implementation Guide for Operators. IATA, ICAO, IFALPA, 2011.
- [2] Fatigue Risk Management at easyJet - a case study. <http://www.raes-hfg.com/reports/30oct12-SMSandFatigue/30oct12-Derbyshire.pdf>, retrieved on 23th October 2016.
- [3] Stewart, S.: The easyJet Fatigue Risk Management System (FRMS). Presented at the FAA Fatigue Management Symposium: Partnership for Solutions. Vienna, VA, 2008.
- [4] Stewart, S., Koornneef, F., Akselsson, R. and Turner, C. (2009) Developing a Safety Management System for Fatigue Related Risks in easyJet. HILAS deliverable, 2009.

AUTHOR INFORMATION

Andrea Brezoňáková, First Officer B737 Norwegian, Norway, PhD. student Air Transport Department, University of Žilina, Slovakia

EFFECTS OF HIGH LEVEL OF AUTOMATION IN THE AIRCRAFT COCKPIT ENVIRONMENT ON PILOT SKILLS AND FUTURE TRAINING REQUIREMENTS

Ing. Daniela Ficová

Qatar Airways, Qatar

Air Transport Department, University of Zilina, Slovakia

daniela.ficova@gmail.com

doc. Ing. Benedikt Badánik, PhD.

Air Transport Department, University of Zilina, Slovakia

benedikt.badanik@fpedas.uniza.sk

Abstract - The present and future challenges of the commercial air transport industry require to maintain growth trends in air traffic and at the same time to ease congestion in the skies without compromising high safety standards. This all leads to natural evolution of the aircraft cockpit environment. The progress starts now with implementation of head-up displays, airport moving maps, interactive electronic checklists, enhanced vision using infrared cameras to enable night time vision and synthetic 3-D vision systems. In future, the technology development will continue with I4D operations, digital taxi real-time uplink of the cleared taxi route via Controller-Pilot Data Link Communication and much more. These modern cockpit features and their necessary future upgrades enable pilots to capitalize on their strengths and help them manage their weaknesses. Information from these systems are presented to the pilots in transparent manner which makes their decision-making process more efficient and safer, especially under stress. Taking into consideration future trends in the cockpit environment, the growth of the air transport and safety requirements, it is necessary to review role of pilots. Aviation is a sphere where progress and continuous innovation is inevitable. Therefore, it is necessary to keep up with the evolution and adapt also the pilot training and education. Many major world top rated airlines have already implemented for example evidence-based trainings as they realized that the role of the pilot in the cockpit is changing. The basic pilot skills are essential but in nowadays air transport operation we also need to take into account that pilots need to have certain managerial skills and therefore balance the training accordingly to make it more efficient. Whether we like it or not, the times of visual approaches and manual flying, especially in big commercial operations, are slowly disappearing. We need to understand this progress and adjust the structure of the pilot training accordingly to be able to deliver the best level of safety efficiency.

Key words - automation, future aircraft cockpit environment, human-machine interface, safety challenges, situational awareness, skills degradation, training.

INTRODUCTION

Since the very first flight on December 17, 1903 when one of the Wright brothers successfully flew for the first time in the history and his ground speed reached 6.8 mph, the aviation has made enormous progress. [3] If we want to analyse the evolution, we need to settle a baseline. For purposes of this article, we will aim the analyses on automation in the aircraft cockpit environment. More specifically, how the pilots perceive it and what is their attitude towards the cockpit automation. Based on this analyses, we can better understand, how to adjust the training to make aviation more efficient and safe.

The main goal in the adoption of aircraft cockpit automation technologies is to decrease the errors caused by human factors. On the other hand, real operation and empirical researches showed that the automation causes new types of errors in the cockpit. Based on aviation accidents survey, the automation errors are mostly related to FMS (Flight Management System) and sudden loss of automation. The FMS supports pilots in flight planning, navigation, performance management and monitoring of flight. The automation enables pilots to capitalize on their strengths and should help them manage their weaknesses.

In order to have a better understanding of this thought, it is necessary to know pilots' attitude towards this phenomena. To understand it, we conducted a survey. This survey and study is aimed at the effect of high automation in the aircraft cockpit environment and its impact on flight safety. The survey was conducted on a group of 128 air transport pilots of the most advanced airline jet aircraft (B787, B777, B737NG, A320, A330 and A380). The group consisted of Airline Instructors/Examiners, Line Captains, Senior First Officers, First Officers and Second Officers. The pilots were from the major world airlines such as Qatar Airways, Amiri, Etihad, Emirates, Norwegian, Vietnam Airways, Ryanair, Travel Service and Lufthansa. Average age of the respondents was 38. 10% of the pilots were women and 90% men. Average flown hours of the pilots were 9500 (total flight time). The summary of personal interviews and the survey is shown in the tables and charts hereinafter.

For global understanding and analysing of the high cockpit automation, its evolution, challenges, future training requirements and its impact on overall safety, it is necessary to compare current perception of the automation from all points of view – pilots, companies, training, ATC, industry and future air transport growth. The survey done for the purposes of this article takes into consideration the pilots' point of view.

SKILLS DEGRADATION, SITUATIONAL AWARENESS, ADVANTAGES, SAFETY CHALLENGES

Looking back to history, big wars produced many military pilots and set a baseline for the big boom of aviation in terms of technology and personnel. The source of pilots was huge and pilot flying skills were, thanks to thousands of flown hours without autopilot, amazing. Later, between 1970s and 1990s, civil pilots earned their honourable place in aviation maintaining the perfect understanding of the aircraft logic. It was standard that pilots grew up in aero clubs closely connected with all the aspects of aviation surrounded by other passionate and dedicated pilots and ground staff. Later development of aviation technology brought innovations and need for crew resource management (CRM) among the crew members. This again enhanced the professionalism and safety level of air transport.

Looking at global aviation industry now, it is obvious that the air traffic has reached its capacity ceiling at many airports and airspaces. On top of that, air traffic is still growing. Even the world fleets' growth rate is tremendous and the number of new aircraft being delivered every year continuously increases [1]. This production and deliveries will in turn drive a growing need in well-trained pilots and crews to fly and operate these aircraft. Human resources are a limiting factor.

Older generation is retiring and more and more new pilots need to be trained to proficiency. The training need to be completed as fast and as cheap as possible in order to be competitive and efficient. We need to cover the world big need for air personnel.

One of the answers is automation. Cockpit automation brings great advantages. Year 2015 pride itself for fatal accidents translating into a rate of 0,03 accidents per million flights [1]. If we study through world aircraft fleets, it is obvious that highly automated aircraft types have significantly lower fatal rate over years [2]. The fact is, the automation also brings new challenges. For experienced pilots who have built sufficient pilot skills, it is very good and strong tool. On the other hand, for pilots, especially cadets/second officers, who were not given enough time to absorb basic flying skills and experience, it could bring challenges such as insufficient understanding of some principles, logic of the systems and more. The recent aviation fatal accidents confirm this. [2] Generally, pilots with experience have strong intuitive reactions (basic pilot skills). If cadet pilots are not given enough practise and opportunity to build these intuitive reactions and depend solely on automation, this is not the right way how the cockpit automation should be used. It is caused by the pressure from the aviation industry on producing pilots fast.

Airlines are aware of this development and of the high reliability of the aircraft systems and encourage pilots to use the automation up to its full capacity. They know how to prioritise and optimise the training to match the current needs. Good idea how to maintain and enhance pilots' flying skills is to give them for example 1 extra simulator per year to practice manual flying (no autopilot, no autothrust, no flight director, manual go-arounds, visual circuits and more scenarios). Such a solution of course brings high costs and is demanding on simulator capacity. Another way how to increase the awareness is to encourage pilots to keep up with the automation, its logic and function and educate them to fully understand it. The results of the survey and interviews indicate that pilots have quite good awareness of all the automation. We need to keep up and lay emphasis especially on second officers/cadets as the current fast trainings and booming air transport development do not provide them with sufficient time to adapt.

RESULTS OF THE SURVEY

The following charts indicate various pilots' attitudes as regards the progressive deployment of the automation to the cockpit environment.

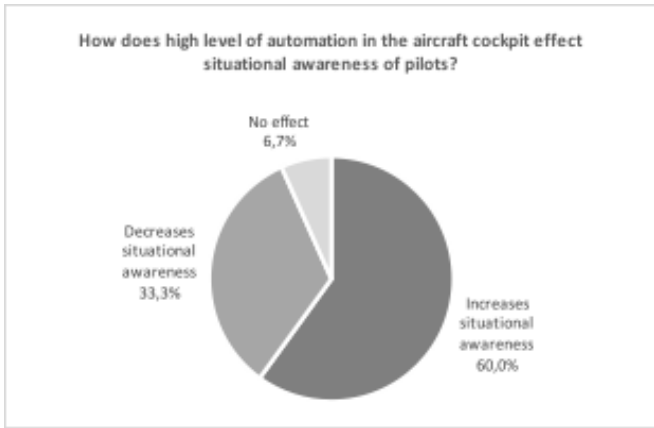

Figure 1 – How does high level of automation in the aircraft cockpit effect situational awareness of pilots?

Based on Figure 1, 60% of the survey respondents agreed that high level of cockpit automation increases situational awareness. This confirms the main objective of the automation – to increase pilots’ situational awareness by decreasing their workload.

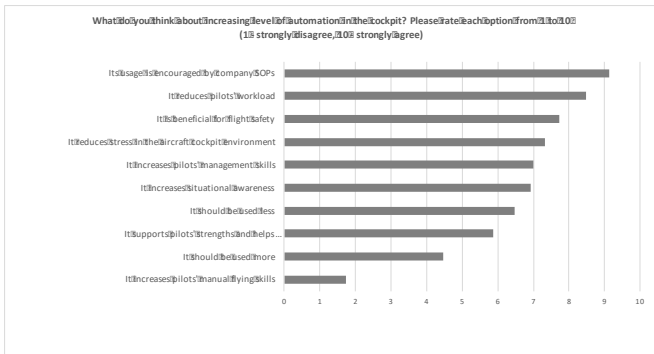

Figure 2 - What do you think about increasing level of automation in the cockpit? Please rate each option from 1 to 10

(1 - strongly disagree, 10 - strongly agree)

Regarding Figure 2, pilots generally strongly agreed that the usage of the cockpit automation is encouraged by the company’s standard operating procedures, it reduces their workload, and it is beneficial for flight safety and increases pilots’ management skills and situational awareness. The lower weighted average of the results showed that pilots agreed the automation should be used less and at the same time it helps to manage their weaknesses and supports their strengths. Pilots generally disagreed that the automation should be used more and strongly disagreed that the automation increases pilots’ manual flying skills.

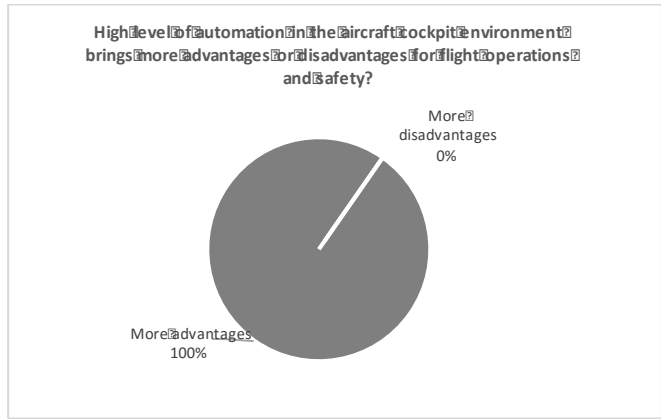

Figure 3 - High level of automation in the aircraft cockpit environment brings more advantages or disadvantages for flight operations and safety?

Figure 3 brings surprisingly united opinion on advantages/disadvantages which brings high level of cockpit automation regarding flight operations and safety. 100% of the respondents agreed it brings more advantages than disadvantages. This result definitely confirms the purpose of the cockpit automation.

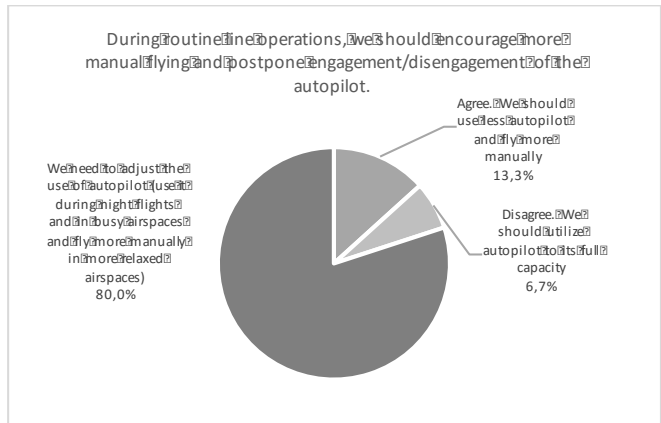

Figure 4 - During routine line operations, we should encourage more manual flying and postpone engagement/disengagement of the autopilot.

The respondents’ opinions slightly differed in question regarding encouraging more manual flying and postponing engagement/disengagement of the autopilot during routine line operations (see Figure 4). 80% of the pilots agreed we need to adjust the use of autopilot (use it during night flights and in busy airspaces and fly more manually in more relaxed airspaces). 13,3% of the pilots agreed we should use less autopilot and fly more manually and 6,7% agreed that we should utilize the autopilot to its full capacity.

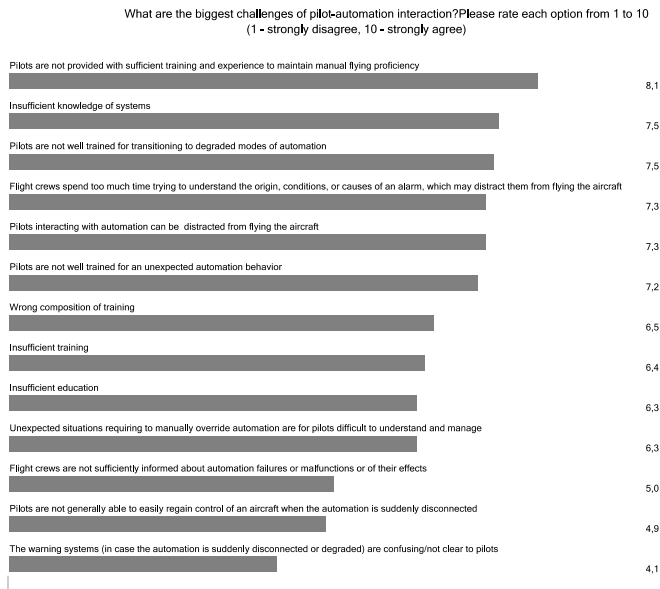

Figure 5 - What are the biggest challenges of pilot-automation interaction? Please rate each option from 1 to 10 (1 - strongly disagree, 10 - strongly agree)

Based on the pilots' responses, the biggest challenge of pilot-automation interaction (see Figure 5) is that pilots are not provided with sufficient training and experience to maintain manual flying proficiency. Here we can ask questions: What kind of proficiency is more important nowadays and what kind of proficiency will be of higher importance in the future: the right usage of the automation or excellent manual flying skills? How to balance these two closely connected requirements efficiently?

Next, pilots also agreed a drawback is also insufficient knowledge of the systems. The respondents also assigned high priority to difficulties in transitioning from automated to manual flight. This is obviously caused by insufficient manual flying. This is why pilots do not feel comfortable and confident enough during manual flying any more.

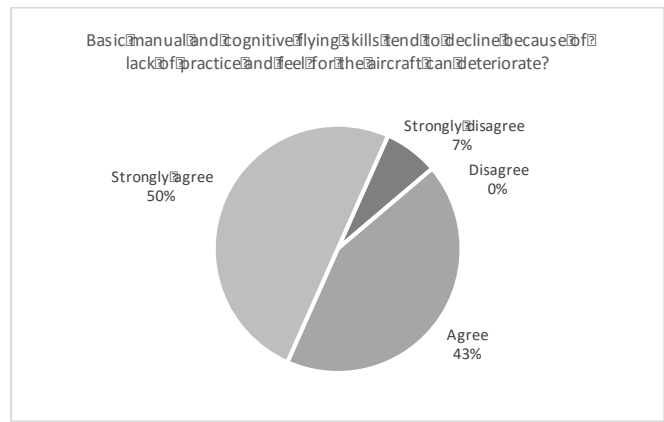

Figure 6 - Basic manual and cognitive flying skills tend to decline because of lack of practice and feel for the aircraft can deteriorate?

Based on the chart shown in Figure 6, 93% of the pilots agreed that basic manual and cognitive flying skills tend to decline because of lack of practice and feel for the aircraft can deteriorate. 7% strongly disagreed.

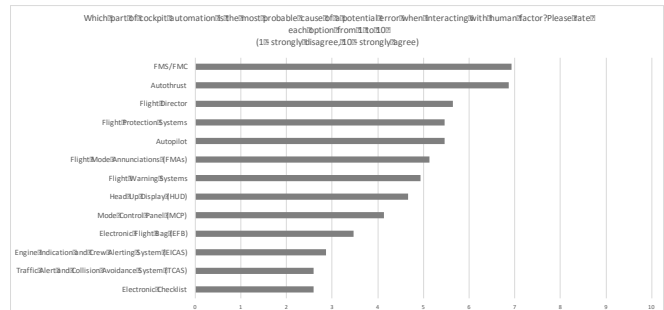

Figure 7 - Which part of cockpit automation is the most probable cause of a potential error when interacting with human factor? Please rate each option from 1 to 10 (1 - strongly disagree, 10 - strongly agree)

Some parts of cockpit automation are more probable cause of a potential error when interacting with human factor. Figure 7 depicts the pilots' opinions on the importance of these automation systems. The highest rating had FMS/FMC, then autothrust, flight director, flight protection systems, autopilot and flight mode annunciation (FMA). The rest of the selected systems were assigned low importance. These systems were: flight warning systems, head up display (HUD) and mode control panel (MCP). Pilots disagreed that electronic flight bag (EFB), engine indication and crew alerting system (EICAS), traffic alert and collision avoidance system (TCAS) and electronic checklists would have significant impact on the potential error when interacting with the human factor.

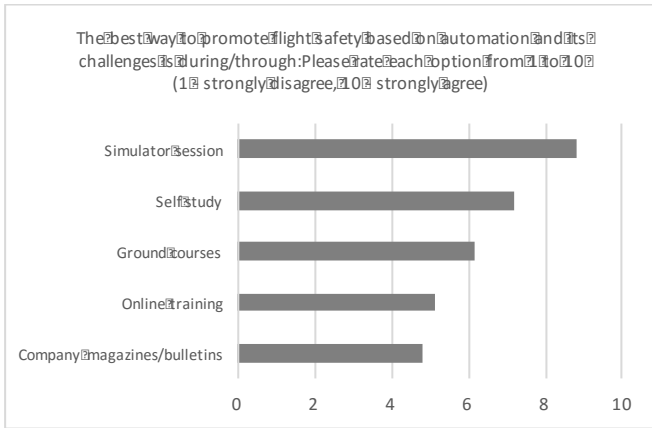

Figure 8 - The best way to promote flight safety based on automation and its challenges is during/through: Please rate each option from 1 to 10 (1 - strongly disagree, 10 - strongly agree).

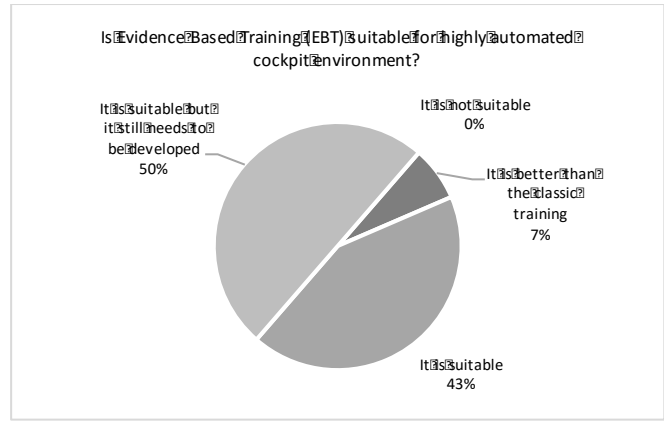

Figure 10 - Is Evidence Based Training (EBT) suitable for highly automated cockpit environment?

Figure 10 shows that the pilots' feedback on the evidence based training (EBT) is generally good.

In the survey, the pilots generally agreed that the best way to promote flight safety based on automation and its challenges is through simulator sessions, self-study and ground courses. (Figure 8)

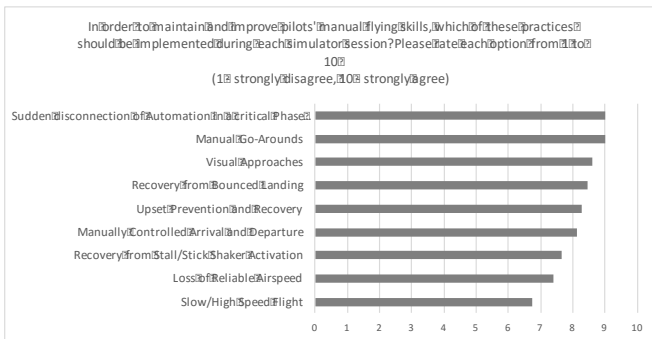

Figure 9 - In order to maintain and improve pilots' manual flying skills, which of these practices should be implemented during each simulator session? Please rate each option from 1 to 10 (1 - strongly disagree, 10 - strongly agree)

In order to maintain and improve pilots' manual flying skills, the respondents were asked which practices should be implemented during each simulator session. The highest priority was given to sudden disconnection of autopilot in a critical phase of flight, manual go-arounds, visual approaches, recovery from bounced landings, upset prevention and recovery, manually controlled arrivals and departures, recovery from stall/stick shaker and loss of reliable airspeed. Little lower importance was given to slow/high speed flight practise (Figure 9). Based on these results, pilot generally want more manual flight training during the simulator sessions.

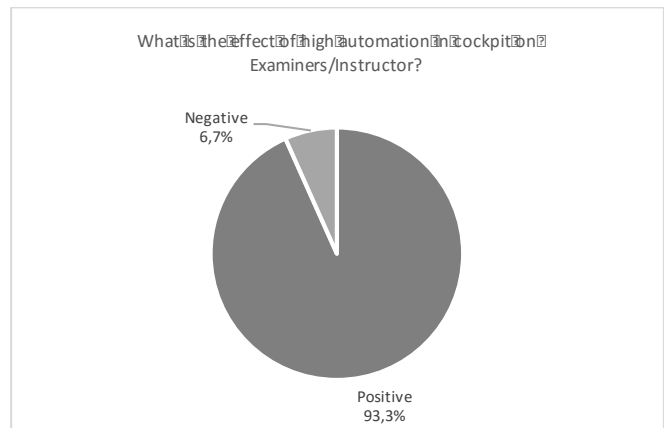

Figure 11 - What is the effect of high automation in cockpit on Examiners/Instructor?

Regarding the effect of high automation in cockpit on Examiners/Instructor, majority of the respondents agreed the effect is positive. It lowers their workload and they can focus more on training. This makes the training process more efficient. See Figure 11.

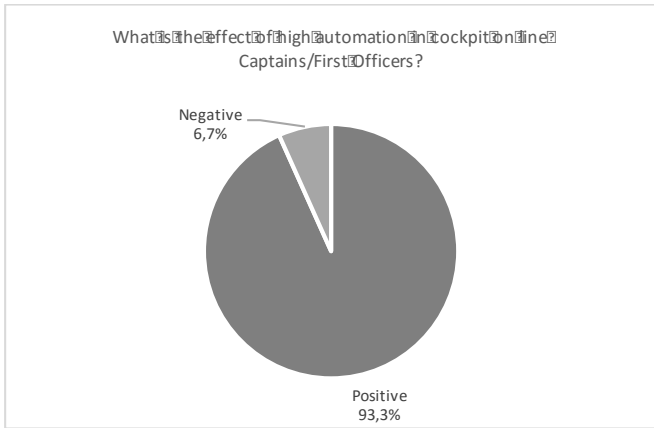

Figure 12 - What is the effect of high automation in cockpit on line Captains/First Officers?

Regarding the effect of high automation in cockpit on line Captains/First Officers, it is also generally agreed that the effect is positive. Provided that the professional captains and first officers have sufficient skills, the automation makes the operations way more efficient and safe. See Figure 12.

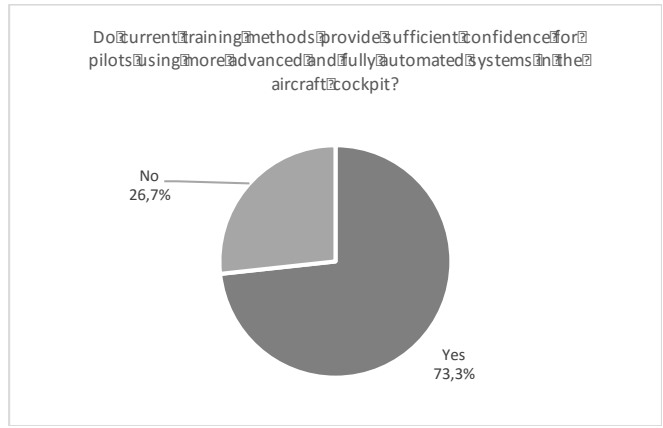

Figure 14 - Do current training methods provide sufficient confidence for pilots using more advanced and fully automated systems in the aircraft cockpit?

The chart in Figure 14 shows that approximately 73% of the respondents agreed that the current training methods provide sufficient confidence for pilots using more advanced and fully automated systems in the aircraft cockpit.

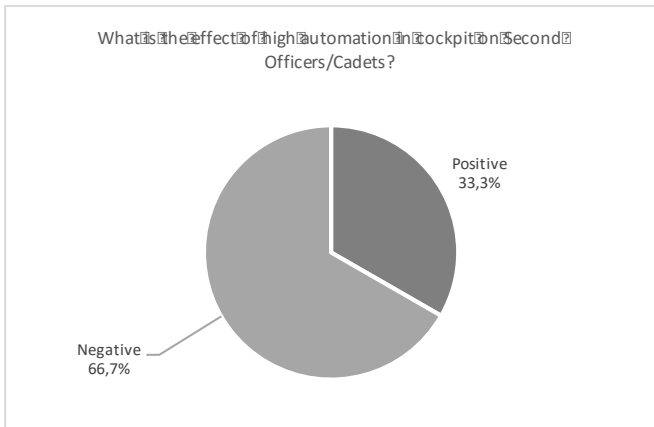

Figure 13 - What is the effect of high automation in cockpit on Second Officers/Cadets?

Approximately 67% of the respondents agreed that the effect of high automation in cockpit on Second Officers/Cadets is negative. The second officers/cadets need to build “intuitive” flying skills and get as much manual flying experience as possible before relying on automation. In this way they fully understand the logic behind the automation and use the automation right. See Figure 13.

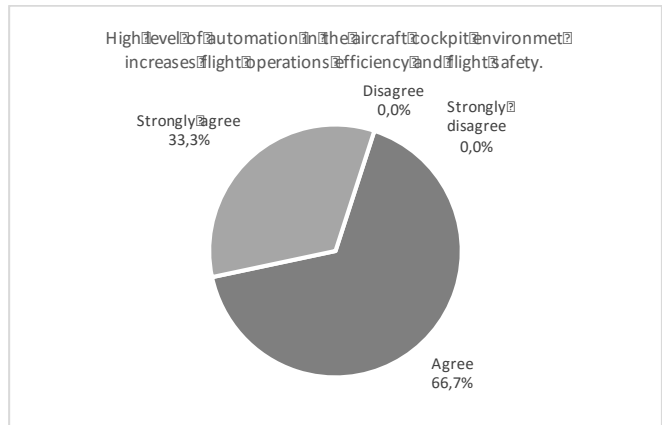

Figure 15 - High level of automation in the aircraft cockpit environment increases flight operations efficiency and flight safety.

Based on Figure 15, approximately 67% of the pilots agreed that high level of automation in the aircraft cockpit environment increases flight operations efficiency and flight safety.

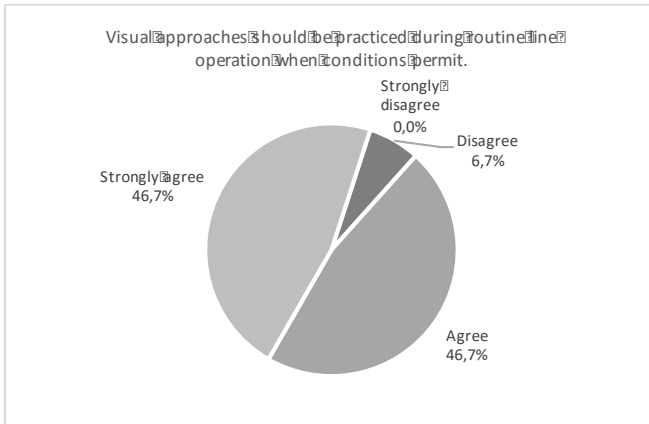

Figure 16 - Visual approaches should be practiced during routine line operation when conditions permit.

Approximately 93% of the respondents agreed that visual approaches should be practiced during routine line operation when conditions permit. See Figure 16. This result confirms the need for more manual flying practice.

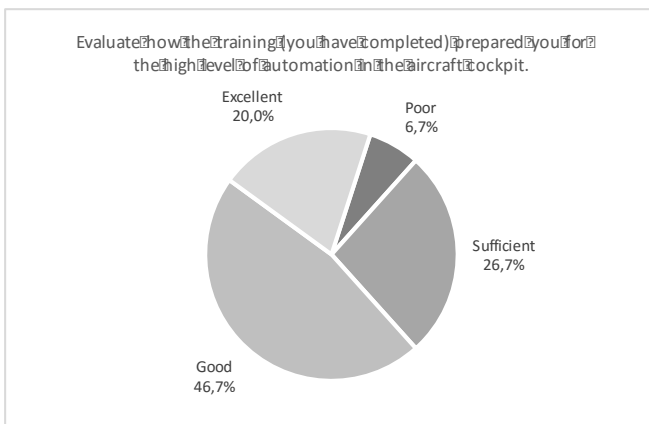

Figure 17 - Evaluate how the training (you have completed) prepared you for the high level of automation in the aircraft cockpit.

Finally, the Figure 17 depicts various opinions on how the training (the pilots have completed) prepared them for the high level of automation in the aircraft cockpit. 6,7% of the respondents thought the preparation was poor. 20% thought it was excellent, 26,7% considered it to be sufficient and 46,7% found it to be good.

DISCUSSIONS AND INTERVIEWS RESULTS

Some additional ideas were collected on what should be changed in the current pilot training (FTO or airline level) so it better addresses issues of increased level of automation in the aircraft cockpit. Many of the respondents agreed on high need for more manual flying in order to maintain skills. Next, there is need for more normal manoeuvre training without the

head up display (HUD) and autothrust as many major airlines do not allow it under normal operations. Results also showed the pilots' need for more upset recovery simulator training and an advanced knowledge of the automatic modes logic. Some of the respondents would like to be given an opportunity to provide their companies with specific feedback about their specific training needs. Generally, both examiners/instructors and line pilots were happy with the new trend of training – evidence based training (EBT). They found it efficient.

Few respondents expressed their concern on the general ability of pilots regarding the usage of various levels or parts of automation that indicates a widespread lack of in-depth knowledge of how the system should be used efficiently; indicating further basic training should be applied to advance system knowledge before continuing to use the automation in normal or non-normal situations.

Especially airlines examiners/instructors agreed that there is need for more flying experience without using autopilot before joining an airline and better understanding of autopilot modes.

CONCLUSION

Preliminary research outcomes suggest that the automation in the aircraft cockpit environment undoubtedly increases flight safety. It supports pilots' strengths and manages pilots' weaknesses. The automation significantly eliminates errors caused by human factors. On top of that, the cockpit automation is being developed by the world's top experts. The trend of aviation surely shows need for even further increase of cockpit automation.

The results of the survey imply that even within airline pilot training environment, "the 70:20:10 Model for Learning and Development" is valid. (70% means real experience, 20% means social interaction with colleagues, 10% is formal education)

One needs to be aware what the automation does, how it should be used, and how to benefit from it as much as possible without compromising safety and pilots' knowledge and skills.

Xunzi (Confucian scholar) said: "Not hearing is not as good as hearing, hearing is not as good as seeing, seeing is not as good as knowing, knowing is not as good as acting; only when a thing produces action can it be truly learned."

REFERENCES

[1] Airbus, A Statistical Analysis of Commercial Aviation Accidents 1958-2015,

- [2] Boeing. Statistical Summary of Commercial Jet Airplane Accidents Worldwide Operations | 1959–2015
- [3] Tom Crouch, Who Flew First?, AIR & SPACE MAGAZINE, September 2013
- [4] ICAO Training Report, Vol. 1, No1 – July/August 2011. The challenges of Continuous Modernization. Addressing looming skilled personnel shortages and the need for industry-wide technology upgrades.
- [5] EASA SIB No 2010-33, Flight Deck Automation Policy - Mode Awareness and Energy State Management, issued 18 Nov 2012.
- [6] Masson M. (2011). EASA Automation Policy. EASA Conference Staying in Control – Loss of Control (LoC) Prevention and Recovery, 4-5 Oct, Cologne, Germany.
- [7] Masson M. (2012). EASA Automation Policy: Bridging Design and Training Principles. European Aviation Safety Seminar (EASS) 2012, Flight Safety Foundation, 29 Feb – 1 Mar, Dublin, Ireland.
- [8] Masson M. (2012). EASA Cockpit Automation Policy – Where Training Meets Design. Preliminary Results of the 2012 Survey. 7th Annual International Flight Crew Training Conference, Royal Aeronautical Society, 26-27 Sep, London.
- [9] The Boeing Company. General Information – All Model Flight Crew Training Manual.
- [10] Federal Aviation Administration. ENHANCED FAA OVERSIGHT COULD REDUCE HAZARDS ASSOCIATED WITH INCREASED USE OF FLIGHT DECK AUTOMATION. Office of Inspector General Audit Report. Report Number: AV-2016-013 Date Issued: January 7, 2016
- [11] Bombardier. BM7013.16 Flight Deck Philosophy. Revision 2008.07.23
- [12] Wood, S.: Flight Crew Reliance on Automation. UK Civil Aviation Authority, 2004/10, West Sussex (2004)
- [13] Wickens, C.D.: Complex Systems, Process Control, and Automation Engineering Psychology and Human Performance, 3rd edition., pp. 538–547. Prentice-Hall, Upper Saddle River, New Jersey (2000)
- [14] Wood, S.: Flight Crew Reliance on Automation. UK Civil Aviation Authority, 2004/10, West Sussex (2004)
- [15] Baberg, T.W.: Man-machine Interface in Modern Transport Systems from an Aviation Perspective. Aerospace Science & Technology 5, 495–504 (2001)

AUTHOR INFORMATION

Daniela Ficová, Airline Pilot B787 Dreamliner, Qatar Airways, Qatar
External PhD. Student, Air Transport Department, University of Zilina, Slovak republic

DEVELOPMENT OF A RISK ASSESSMENT TOOL FOR SESAR'S DESIGN-IN SECURITY APPROACH

Karol GÓTZ, Martin HAWLEY

Winsland Ltd., Richmond, UK

karol.gotz@winsland.org, martin.hawley@winsland.org

John HIRD

EUROCONTROL, Brussels, Belgium

john.hird@eurocontrol.int

Chris MACHIN

Aztech BVBA, Mechelen, Belgium

chris.machin@aztech.be

Abstract - To support the approach of 'design-in security' taken by the SESAR Programme, the authors have iteratively developed a support tool, known as 'CTRL_S' that guides users through the security risk assessment process. Whilst these risks are mostly generic, based on prototype system architectures or extrapolations from current systems, the approach supports the development of security controls through to operations. Key aspects of the CTRL_S tool have been to support 'cross-sectional' analyses of risk assessments and to create a collaborative knowledge-based approach.

Key words - security; security management; air traffic management; security risk assessment; security tools.

INTRODUCTION

The year 2016 sees the closure of the first phase of SESAR, a European programme also known as the technological 'pillar' of the 'Single European Sky' (SES). As SESAR has been developing new operational concepts and supporting technologies, an underlying concern has been the security of future Air Traffic Management (ATM) systems, with focus on 'cyber' security. Within SESAR, the aim is to 'design-in' security to reduce security risk by precipitate action at the design stage and reduce costs in deployment, hence SESAR projects have been encouraged to perform risk assessments from an early stage. This means that security requirements should be included in the 'Safety and Performance

Requirements' developed for the industrialisation and eventual deployment phases of SESAR.

In many respects the inclusion of security in ATM operational development follows the path taken in introducing safety as a design requirement. Safety assessment was never intended to be the preserve of experts only and so too was security in SESAR, which led to a method-driven approach to be followed by all projects with 'hands-on' support by security experts. Another similarity is that for security, methods used in other industries have been adapted for the specific nature of ATM. Those charged with developing the methodology have also sought ways to reduce the burden of its application, not least by road-testing the methodology throughout the programme (around 20 risk assessments are being entered into the tool). This has led to initial methods being refined and simplified and supporting tools to be developed. One such tool is 'CTRL_S', so named to symbolise the security controls to be applied to SESAR-developed technology.

THE EVOLUTION OF CTRL_S

Early on in the SESAR programme few risk assessments were carried out and these tended to be at a high level. The spreadsheet model was applied to a test case to explore ease of use for large scale assessments. The test case was a

risk assessment that identified 23 Primary Assets (items which are important for ATM operations such as information and services) and around 70 Supporting Assets (the people, procedures, infrastructure which provided the primary assets), of which about half were used in the scope of the assessment. Threat scenarios were created from 22 generic threat types.

The principle adopted was to enter data only once and allow this to be propagated throughout the spreadsheet. The risk assessment method, based on ISO27005, has certain steps that could be described as a series of array transformations. The scale of the test case would make it difficult and time consuming to undertake the risk assessment using manual table entry and manipulation.

Whilst the test case illustrated the benefits of automated steps, using MS Excel had some drawbacks, principally that there was a loss of traceability from end to end in the process. For example, the risk methodology takes the maximum impact of a compromise of confidentiality (C), integrity (I) or availability (A) on a primary asset through to the subsequent steps. At the stage of applying controls however, it is important to retain a knowledge of the different C, I or A impacts for correct control choice. This was deemed overly complex to implement in MS Excel and therefore the authors opted to use MS Access. This decision was based on the expediency needed at this stage in the programme, recognising that MS applications were widely used within the SESAR community.

A further requirement for the tool was to be able to consolidate the data from all risk assessments so that analyses across multiple risk assessments could be carried out. Such analyses were articulated as ‘end-to-end-scenarios’ with the intent of exploring the different controls that might be applied to particular supporting assets, or the different impacts assessed for different primary assets. In developing this solution it was apparent that the architecture being developed could be useful in a wider collaborative sense, such as exchanging information between the central repository to build catalogues of assets, threats, controls etc., as well as exchanging results.

DESCRIPTION OF CTRL_S

In this section we describe the overall function and architecture of CTRL_S.

A. CTRL_S functions

The CTRL_S tool has been designed around the SESAR risk assessment method and is structured in the following steps:

1. Describe the SESAR ‘Solution’ being assessed. (SESAR Solutions are units of operational and technological improvements within the context of ATM modernisation).
2. Define Primary Assets. This includes the impact assessment, where users enter the impact on the ATM

system if there were a compromise of C, I or A on the Primary Asset.

3. Define Supporting Assets.
4. Link Supporting Assets to Primary Assets, or vice-versa. In the first pass, the supporting assets are assumed to inherit the maximum impact of the primary assets supported. The database maintains the separate CIA impacts for traceability as discussed earlier.
5. Define threat scenarios, whereby a potential threat could act on a supporting asset and thereby instigate the impact defined for the one or more primary assets that it supports.
6. Determine risks, by reviewing each threat scenario’s impact and attaching an estimate of likelihood.
7. Determine treatment for each risk, mostly to treat the risk by recommending generic controls. At the early design stages generic controls only are used because the detailed system implementation is unknown. For example data may be recommended for encryption, but not to what type or level.

In addition to the above there is a vulnerability step in development, whereby users may assign generic vulnerabilities to supporting assets and use this to ‘down-select’ threats. The approach to vulnerability assessment is not defined in detail within the SESAR risk assessment methodology so the approach taken is that of the EBIOS methodology.

To make the above steps easier for users, a number of features have been developed:

- A catalogue approach, whereby catalogues are defined for known assets (primary and supporting) types of vulnerability, threats and controls.
- Administration tools so that users can create their own assets, threats, controls and vulnerabilities and make links between them. Furthermore, controls can be specified for each threat type, or vulnerabilities can be linked to those threats that may exploit them.
- Comment fields, to preserve the rationale for decisions taken in the risk assessment, such as: impacts determined, supporting assets included in the assessment, reviewed risks, controls applied, residual risks.

B. Knowledge sharing in CTRL_S

An essential feature of the tool is to support knowledge sharing and this is done through a series of data tables or ‘catalogues’. For the SESAR programme the catalogue approach was appealing because there is a common use of supporting assets. For example, several SESAR solutions may in future be implemented on a common ‘Controller Working Position’ (CWP). As risk assessments are carried out for different SESAR Solutions, a body of knowledge is built up around the perceived risks to particular supporting assets and the controls which should be applied. This can lead to further investigations across several risk assessments, essentially carrying our cross sectional analyses on asset types, risks or control recommendations. The idea behind this

type of analysis is to learn from different risk assessments and also identify possible gaps.

C. CTRL_S architecture

CTRL_S is a database tool designed to help users proceed with Security Risk Assessments (SRA). It comprises of two main parts, a local and centralised part. The local part is a standalone tool for security risk assessment. The Central Repository stores all the catalogues, SRA results and users' short details. Currently the CR is stored on the cloud because it is used by multiple organisations.

The local part CTRL_S; is a relation database tool built on the formal steps of the SESAR Security Risk Assessment Method. MS Access is available to most users and if not MS Access Runtime may be used to run the tool. CTRL_S presents all steps needed for the risk assessment in a comprehensive and clear way to users.

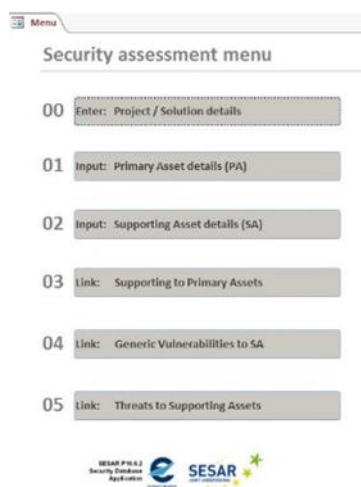

Figure 1 Part of the CTRL_S tool main menu

As the local copy is a standalone file, users are required to use one file for each assessment. Whilst this does not allow collaborative work, it is a practical way of entering data and maintaining security. To keep records of highly sensitive data and information secured, it is reasonable to store such records 'in-house', therefore separated from the outside, non-corporate networks. The local part enables users to work with given / downloaded inputs (catalogues) or to create their own inputs. These two ways can be used for each element of the SRA, Primary and Supporting Assets, Vulnerabilities, Threats and Controls.

The following figure represents relationship between the local and the centralised part of CTRL_S.

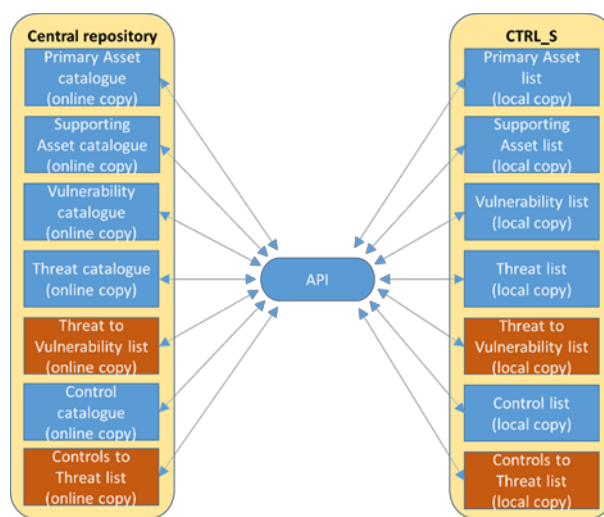

Figure 2 Data synchronised between CTRL_S central and local part

The CTRL_S catalogues are pre-defined lists of items or connections between them. The local part of CTRL_S is empty on first use, requiring the catalogues to be downloaded. The download is via a secured connection and is a subject of log-in procedure. The synchronization (download/update/upload) process is not automatic, which gives users control over the content that is shared.

Catalogues and pre-defined lists of connections are stored in the Central Repository. Connection between the CTRL_S and the Central Repository is secured by SSL. Not all data is synchronised with the Central Repository, which leaves the more sensitive risk assessment rationales and descriptions to the local part.

Where users create new catalogue entries they are initially flagged for local use only. For instance, a user may create a new supporting asset, which may have not been previously defined or is a sub-component of an existing asset that the user wants to address in detail. An administrator role in the central repository is then used periodically to determine whether the new asset should be available for wider use and adopted in the asset catalogue.

The Central Repository also hosts unique records for each user, but as these may not all be 'approved' they are not necessarily available to other users (Figure 3).

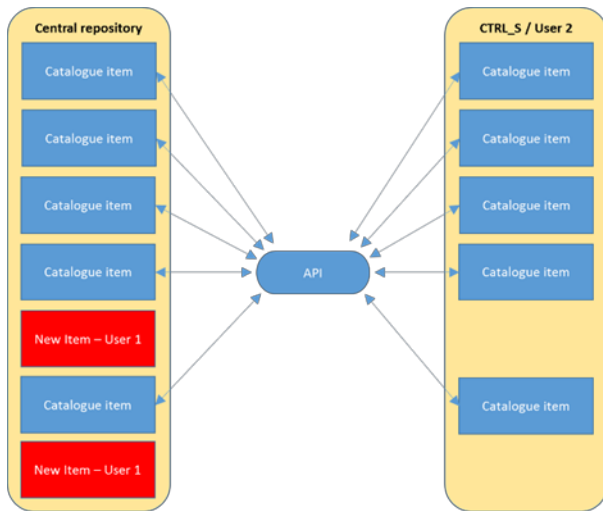

Figure 3 User level access to data stored within the Central Repository

A procedure has been developed for reviewing and adopting new catalogue entries. Following the procedure, the user is required to contact security experts for support in finding a suitable solution within the current catalogue.

In summary, the CTRL_S architecture provides a means of sharing knowledge throughout the SESAR security community of practice. Each local MS Access database application is used to capture a single risk assessment. The central database is used to download the latest catalogues at the start of a risk assessment and to upload the key parameters of the risk assessment (assets used, risks identified, controls recommended).

CONCLUSIONS

In this paper we have described the rationale and formulation of CTRL_S, an MS Access based support tool for conducting

security assessments in the SESAR programme. The tool has proven to be popular within the SESAR security transversal area's 'community of practice', who have also contributed greatly to improving its usability and functions. Whilst CTRL_S has been developed for SESAR, it could also support more general application to the ATM domain and wider.

REFERENCES

- [1] European ATM Master Plan Ed. 2, October 2012.
- [2] R Koelle and M Hawley, 'SESAR security 2020: how to embed and assure security in system-of-systems engineering?', Integrated Communications, Navigation and Surveillance Conference (ICNS), 24-26 April 2012.
- [3] L'Agence nationale de la sécurité des systèmes d'information (ANSSI), 'Expression des Besoins et Identification des Objectifs de Sécurité', 2010.
- [4] NIST - Security controls, <http://csrc.nist.gov/groups/SMA/fisma/controls.html>, online 15th April 2016.
- [5] ISO/IEC 27002:2013, http://www.iso.org/iso/catalogue_detail?csnumber=54533, online 15th April 2016.
- [6] F Bergomi et al, 'Beyond Traceability - Compared Approaches to Consistent Security Risk Assessments', 2013 International Conference on Availability, Reliability and Security.
- [7] M Hawley, K Götz, J Hird, Ch. Machin, 'Design-in security for air traffic control', International Conference on Availability, Reliability and Security (ARES), 8-12 September 2014.

SAFETY ASSESSMENT FOR LIGHT REMOTELY PILOTED AIRCRAFT SYSTEMS

Giorgio Guglieri

Dipartimento di Ingegneria Meccanica e Aerospaziale, Politecnico di Torino, Italy

giorgio.guglieri@polito.it

Gianluca Ristorto

Mavtech srl, Bozen, Italy

gianluca.ristorto@mavtech.eu

Abstract - In the last years, Remotely Piloted Aircraft Systems (RPAS) have been developed for a variety of civil applications, such as agriculture, aerial photogrammetry and topographic mapping, environmental monitoring, search and rescue, prevent of fires and disasters, environmental research, monitoring of artistic heritage and general photography and videos. Multi-rotor and fixed-wing configurations are the most common platforms, but for the next years lighter-than-air vehicles (i.e. blimps) could represent an important niche market. In order to establish a set of rules to ensure the safety of RPAS operations, many countries have developed regulation for RPAS with a Maximum Take-Off Mass (MTOM) of less than 150 kg. In 2015, ENAC, the Italian aviation authority, has published the second edition of the regulatory issues for this kind of aircraft. This edition looks ahead to the forthcoming common EU regulation and further amendments will be considered based on (EASA, 2015) and further EASA reports. The reference rules introduce a distinction between RPAS with a MTOM equal to or larger than 25 kg and RPAS with MTOM of less than 25 kg. The operator must provide to ENAC a series of documents that demonstrate that the system is compliant with the regulatory restrictions, in particular the results of risk assessment in order to motivate the safety of the in-flight operations. The aim of this paper is the presentation of a novel methodology for risk assessment applied to different RPAS with a MTOM lower than 25 kg, also including lighter-than-air configurations. This methodology concerns with ground impacts and does not cover the aspects of mid-air collisions. The results of this analysis provide a comprehensive insight for mission feasibility and operational implications in a set of realistic application cases. Practical solutions are proposed for risk mitigation of RPAS operations enforcing a concept of general validity, also compliant with forthcoming common EU regulations, applicable at continental level.

Key words - Remotely Piloted Aircraft Systems, Unmanned Aerial Vehicles, Certification procedures, Risk Assessment.

BACKGROUND

Unmanned Aircraft Systems (UAS) have been hugely developed in recent years. In particular small Unmanned Aerial Vehicles (UAVs) can be used in civil application such as agriculture, traffic monitoring, prevention of fires and disaster, search and rescue, environmental research, pollution, monitoring of the artistic heritage but also general photography and videos. Many countries have developed regulation to allow UAS integration in their National Airspace Systems (NAS). The regulations basic principle give to UAS an Equivalent Level of Safety (ELOS) to that of manned aviation.

In December 2013, the Italian Civil Aviation Authority (Ente Nazionale per l'Aviazione Civile, ENAC) published the regulation on RPAS with MTOM of less than 150 kg and the regulation came into force at the end of April 2014.

In 2015, the Italian Civil Aviation Authority (Ente Nazionale per l'Aviazione Civile, ENAC) has published the second edition of the regulatory issues for RPAS with MTOM of less than 150 kg. This edition looks ahead to the forthcoming common EU regulation and further amendments will be considered based on (EASA, 2015) and further EASA reports. The use of the term RPAS is to emphasize that, although not on board, the pilot is always present and has the capability to control anytime the RPAS flight.

The regulation makes a distinction between RPAS with MTOM equal to or more than 25 kg and RPAS with MTOM of less than 25 kg. For the latter simplified procedures are applied if the operations are not critical. Non-critical and

critical operations are defined in (ENAC, 2013). Non-critical operations are those operations conducted in areas such that an impact on the ground does not cause fatal injuries to people on the ground or severe damage to third parties (buildings, infrastructures, ...) on the ground. Non-critical operations are performed in the volume of space up to 150 m (500 ft) above the ground and up to 500 m radius. The operator must provide to ENAC a series of documents that state that the system is compliant with the regulation. The operator must provide to ENAC the results of risk assessment in order to motivate the safety of the planned operations, for both critical and non-critical specialized operation.

Several works have been made in assessment of risk for UAS operations. Clothier (2006) provided a discussion on the definition and application of safety objectives to ensure appropriate requirements for UAS operations. A simple ground fatality expectation model is also used to illustrate the influence of safety objectives variation on the design and operations of UAS. Lum and Waggoner (2011) proposed a risk model for both midair collision and ground collision. The same model is applied in (Lum et al, 2011) to assess the risk associated with operating an UAS in a populated area. Weibell (2005) introduced the concept of risk mitigation for small UAVs. Size of potential impact area, kinetic energy at impact and system design of small UAVs decrease the ground fatality risk.

The aim of this paper is the presentation of a novel methodology for risk assessment applied to different powered RPASs with a MTOM lower than 25 kg, also including lighter-than-air configurations, eventually tethered for critical operational environments. This methodology concerns with ground impacts and does not cover the aspects of mid-air collisions. The results of this analysis provide a comprehensive insight for mission feasibility and operational implications in a set of realistic application cases. Practical solutions are proposed for risk mitigation of RPAS operations enforcing a concept of general validity, also compliant with forthcoming common EU regulations, applicable at continental level.

The paper is organized as follows. Powered RPAS risk assessment is presented in section 2, while the case of a lighter than air unpowered vehicle (tethered blimp) is illustrated in section 3. The description of the RPAS and the blimp is given in Section 4 while the operative scenario is illustrated in Section 5. Section 6 provides the risk assessment results. The paper concludes with discussion of the results.

The buffer area

The buffer area is a safety distance between the area of operations and adjacent areas that are not subjected to overflight in normal operation. Adjacent areas may be involved in case of uncontrolled flight of the RPAS. The buffer area is computed considering the behavior of the aircraft during a failure. Typically for a multicopter is considered a ballistic trajectory, while for the fixed-wing aircraft a glide constant angle of 45 degrees is assumed during the falling phase.

Method for risk assessment

The methodology here proposed (Guglieri et al., 2014) concerns with ground impact and does not cover the aspect of mid-air collisions. The method considers:

- Casualty area of impacting debris (Ac).
- Population density (Dp).
- Probability of fatal injuries to people exposed to the crash (Pf).

RPAS dimensions (wingspan or propeller diameter for fixed-wing aircraft and diagonal wheelbase for multicopter), glide angle (γ) and height and width of an average human determine Ac. For further details see (FAA, 2000).

Pf is computed considering the kinetic energy at impact and sheltering. Sheltering is an important factor considered in this method. Indeed, trees, buildings, vehicles and other obstacles can shelter a person from the impact, reducing the probability of fatal injuries. The sheltering factor in Pf is an absolute real number. In (Guglieri et al., 2014) Pf is evaluated according to a qualitative estimation of the operative scenario (Table 1).

European airline industry is highly dynamic, competitive and has gone through many changes. The term *low-cost airlines* is often used for carriers if they have homogeneous operations that lead to reducing operational costs as much as possible. However, there are variations of the business model, as well as significant diversities between airlines (Calder, 2002); (Gillen, Morrison, 2003). Nevertheless, the success of LCCs has not risen from market deregulation alone. Liberalisation played notable role, but it was not sufficient condition for the spreading of the LCCs. Other significant catalysts that supported the entry of low-cost airlines in the aviation market include entrepreneurship, population, airport availability, or price transparency. The typical LCCs profile could be described by three key components: product, market positioning and operating costs (see Table 1).

Table 1 Sheltering factor

Sheltering	Area
0 %	No obstacles
25 %	Sparse trees
50 %	Trees and low buildings
75 %	High buildings
100 %	Industrial area

The sheltering percentage (from 0% to 100%) is associated to the type of shelter that trees and/or buildings may provide to people on the ground. Sheltering percentage must be averaged over the area of operations, buffer zone included (indicatively for a 2km x 2km square) and weighted with the population density.

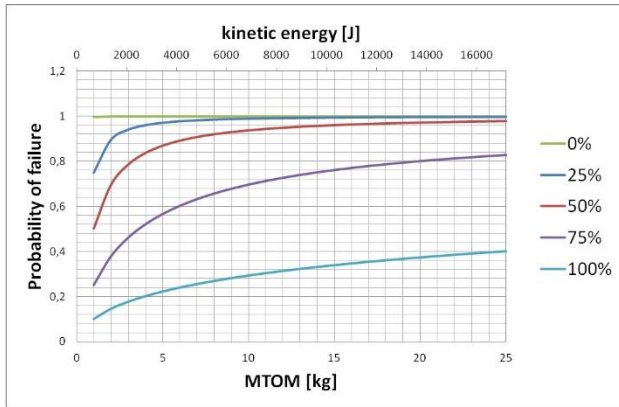

Figure 18 Probability of fatality as a function of RPAS MTOM and percentage of sheltering, @ V = 37 m/s

Probability of fatality as a function of the MTOM is presented in Figure 18. Sheltering percentage is the parameter. The graph is obtained starting from the kinetic energy at impact computed as

$$E_{CIN} = \frac{1}{2}MV^2 \quad (1)$$

Where M is the MTOM and V is the velocity at impact. In this case V is set equal as the free fall velocity from an altitude of 70 m, that is approximately 37 m/s.

In this paper the maximum acceptable probability for on ground victims per fatal RPAS accident is computed as in (FAA, 2000) with the percentage sheltering factor proposed in (Guglieri et al., 2014):

$$P = \frac{N}{A_C \cdot D_P \cdot P_f} \quad (2)$$

where N is the number of on ground victims per flight hour and it is set equal to 10^{-6} as safety objectives.

In case of nonhomogeneous population density areas, the introduction of a G probability factor considers that RPAS may crash in a specific area

$$P_i = \frac{N}{A_C \cdot G_i \cdot D_{P,i} \cdot P_{f,i}} \quad (3)$$

The reciprocal of the maximum probability is then compared with the reliability of the RPAS. Because the components of this kind of aircraft derive from model aircrafts, it is impossible to evaluate the reliability of the overall system. (FAA, 2015) assumes an acceptable value for MTBF of 100 hours.

LIGHTER THAN AIR UNPOWERED VEHICLE RISK ASSESSMENT

The buffer area

In order to evaluate the buffer area some simplifying hypotheses are considered:

- The disengagement of the payload and its impact on people on the ground is considered lethal.
- The impact of the envelope is considered inoffensive because the kind of material.
- The height of the people is neglected.
- The model of impact is punctual.

The horizontal distance covered by the falling payload represents the buffer area. When there is no wind, the blimp will stay on the vertical of the anchoring point and the payload will fall inside a cone of semi-aperture $\alpha = 30^\circ$ (Chyba! Nenašiel sa žiaden zdroj odkazov.). In this condition, the buffer radius is

$$r_{xP} = L \cdot \tan \alpha \quad (4)$$

where L is the height of the falling payload (length of the retention cable).

In windy conditions, the blimp assumes different position due to the aerodynamic drag that affect the envelope (Chyba! Nenašiel sa žiaden zdroj odkazov.).

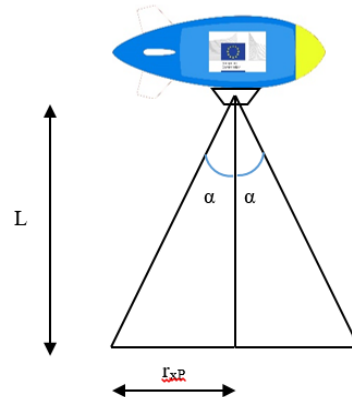

Figure 19 Blimp position in no wind condition.

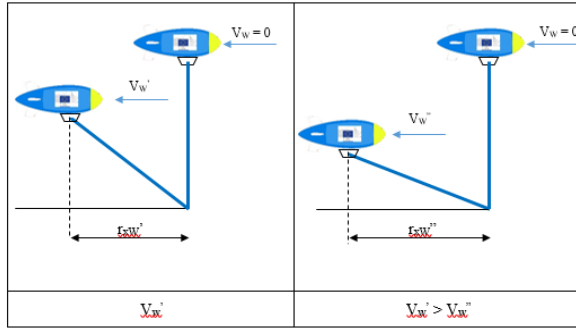

Figure 20 Blimp position in windy conditions.

The buffer radius is

$$r_B = r_{xP} + r_{xW} \quad (5)$$

and it is measured on the vertical of the anchoring point. Furthermore, according to **Chyba! Nenašiel sa žiaden zdroj odkazov.** the horizontal distance covered by the falling payload in windy conditions is lower than the horizontal distance in still air.

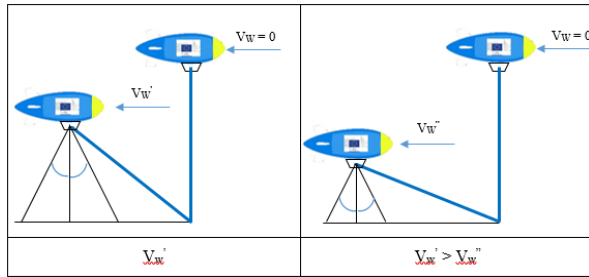

Figure 21 Effect of the wind on the horizontal projection of the falling payload.

Retention cable ultimate wind load

The wind speed for which the retention cable breaks is calculated by matching the aerodynamic drag and the ultimate load of the retention cable:

$$\frac{1}{2} \cdot \rho \cdot V_W^2 \cdot S \cdot C_D = R_C \quad (6)$$

where

ρ	Air density	1.225 [kg/m ³]
V_w	Wind speed	[m/s]
S	Equivalent sphere frontal surface	[m ²]
C_D	Sphere drag coefficient	0.47 [-]
R_C	Ultimate load of the retention cable	3850 [N]

Reversing eq (6), we obtain the ultimate wind load:

$$V_W = \sqrt{\frac{2 \cdot R_C}{\rho \cdot S \cdot C_D}}$$

Wind limitations

It is assumed a maximum operator strength of

$$F_{lim} = 30 \text{ kg} = 294.3 \text{ N}$$

According to equation (7), it is possible to operate in windy condition if the aerodynamic drag of the equivalent sphere is lower than the maximum operator muscular strength.

$$F_W = \frac{1}{2} \cdot \rho \cdot V_W^2 \cdot S \cdot C_D < F_{lim} \quad (7)$$

THE AERIAL VEHICLES

Four reference RPASs developed by MAVTech srl (www.mavtech.eu), a former spin-off of Politecnico di Torino, have been considered for the risk assessment. The MH850 is a fixed-wing aircraft, characterized by tailless wing-body configuration, two twins non-movable vertical fins at wing tips, electric propulsion in tractor configuration (Figure 22). Wings are made of EPP (Expanded Polypropilene) thus the aircraft is durable for damages. The wingspan is 872 mm, the fuselage length is 450 mm, the propeller diameter is 230 mm and it weighs 1 kg. The AGRI-2000 (Figure 23) has the same configuration of the MH850 except that the electric propulsion is in pusher configuration and the entire structure is in molded EPO. The wingspan is 2120 mm, the fuselage length is 770 mm, the propeller diameter is 330 mm and the Agri-2000 weighs 4 kg. The Q4-Rotor-Light (Q4L, Figure 24) is a multicopter characterized by four booms and four rotors. The diagonal wheelbase is 0.6 m and it weighs 1.8 kg. Finally, the Q4-Rotor-Power (Q4P, Figure 25) is the heavier version of the Q4L. The diagonal wheelbase is 1.880 m and it weighs 7.5 kg.



Figure 22 – The MH850



Figure 23 – The AGRI-2000



Figure 24 – The Q4L



Figure 25 – The Q4P



Figure 26 – Blimp ZNYL-900
(www.technofly2008.com).

The model of the tethered blimp is the ZNYL-900 (Figure 26) and it has a double envelope (inner envelope polyurethane, outer envelope nylon). The ZNYL-900 has inflatable stabilizers. The fuselage length is 9 m, while the maximum diameter is 3,38 m. The estimated volume is 45 m³ and the ZNYL-900 has a maximum payload of 10 kg. The retention cable is in Dyneema® SK99 and its main features are summarized in Table 2.

Table 2 – Retention cable main features

Length (Max)	Diameter	Ultimate Load	Linear weight
[m]	[mm]	[N]	[g/m]
120	1.5	3850	1.6

A winch is used to stretch the retention cable. The winch has a maximum load capacity of 20 kg.

SCENARIO

Two types of scenarios have been considered for powered RPAS risk assessment: a non-critical scenario and a critical one. The non-critical scenario is characterized by uniform population density of 5 habitants per km² and a sheltering percentage of 25%. The critical scenario is a real case. The area considered is that of Torino Aeritalia Airport (I-LIMA). It is located in the North-West of the city, on the border between Torino and the town of Collegno. The area is depicted in **Chyba! Nenašiel sa žiaden zdroj odkazov.**, while **Chyba! Nenašiel sa žiaden zdroj odkazov.** shows the area of operation (red circle, 400 m radius), the buffer area (green circle, 600 m radius) and the adjacent areas (yellow circle, 700 m radius). Torino Aeritalia Airport can be a promising site for RPAS experimental activities. Flight operations take place in the red circle. The site is characterized by different population density and offers

different kind of shelter for people on ground. Agricultural lands (North) are characterized by low population density and few trees offer poor shelter. Whereas, industrial buildings (South and West) offer high population density but also high values of sheltering factor. In order to evaluate the average population density and sheltering factor, the area has been partitioned in 3 slices (Figure 29). For each area, population density ($D_{p,i}$) and sheltering percentage (P_s) are estimated and the average value has been evaluated (see Chyba! Nenašiel sa žiaden zdroj odkazov.).



Figure 27 – Torino-Aeritalia Airport

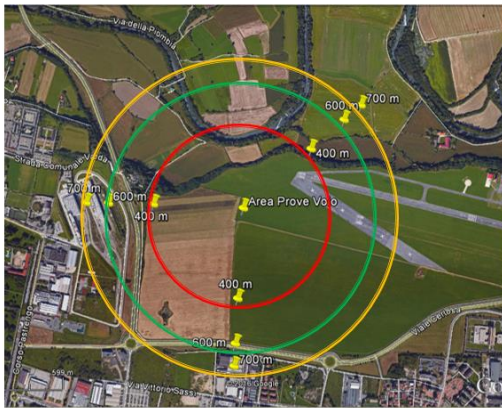

Figure 28 – Area of operations (RED), buffer area (GREEN) and adjacent area (YELLOW)



Figure 29 – Partition of the area

Table 3 - Estimation of population density and sheltering percentage for each slice of the scenario

Sector	$\Delta\alpha$	G_i	S	Habitants	$D_{p,i}$	Sheltering %
[-]	[deg]	[-]	[km ²]	[people]	[people/km ²]	[%]
1	85	0.236	0.363	50	138	50
2	65	0.181	0.278	100	360	75
3	210	0.583	0.583	10	11	25

The probability of fatality is then estimated for each RPAS in each sector of the scenario.

RESULTS

Powered RPAS risk assessment results

Results for non critical scenario are shown in Table 4, while Table 5, Table 6, Table 7 and Table 8 illustrate the results for critical scenario of each aircraft considered in the risk analysis.

Table 4 – Results for non-critical scenario ($D_p = 5$ people/km²)

	A_c	P_f	P	1/P
	[m ²]	[-]	[1/h]	[h]
MH850	2,247	0,559	0,159	6
AGRI-2000	2,924	0,876	0,078	13
Q4L	4,907	0,750	0,054	18
Q4P	15,957	0,950	0,013	76

Table 5 – MH850 results for critical scenario

Sect.	A_c	D_p	G_i	E_{cin}	Shelt.	P_f	P	1/P
[-]	[m ²]	[people/km ²]	[-]	[J]	[%]	[-]	[1/h]	[h]
1	2,247	138	0,236	1472	50	0,514	0,027	38
2		360	0,181		75	0,258	0,026	38
3		11	0,583		25	0,762	0,091	11

Table 6 – AGRI-2000 results for critical scenario

Sect.	A_c	D_p	G_i	E_{cin}	Shelt.	P_f	P	1/P
[-]	[m ²]	[people/km ²]	[-]	[J]	[%]	[-]	[1/h]	[h]
1	2,924	138	0,236	5886	50	0,799	0,013	76
2		360	0,181		75	0,477	0,011	91
3		11	0,583		25	0,947	0,056	18

Table 7 – Q4L results for critical scenario

Sect.	Ac	Dp	Gi	Ecin	Shelt	Pf	P	1/P
[-]	[m ²]	[people/km ²]	[-]	[J]	[%]	[-]	[1/h]	[h]
1	4,579	138	0,236	2739	50	0,659	0,010	98
2		360	0,181		75	0,351	0,010	105
3		11	0,583		25	0,876	0,039	26

Table 8 – Q4P results for critical scenario

Sect	Ac	Dp	Gi	Ecin	Shelt	Pf	P	1/P
[-]	[m ²]	[people/km ²]	[-]	[J]	[%]	[-]	[1/h]	[h]
1	15,332	138	0,236	11411	50	0,881	0,002	440
2		360	0,181		75	0,587	0,002	587
3		11	0,583		25	0,976	0,010	96

Lighter than air vehicles risk assessment results

The following tables summarize the effect of wind on height of the blimp (h), horizontal projection of the falling payload (rxP), horizontal distance of the blimp with respect the anchoring point and buffer radius (rB) for three different lengths of the retention cable $L = \{20, 40, 100\} [m]$ and for a net thrust (FN) of 10 kg.

Table 9 – Buffer radius (L = 20 m)

L = 20 m	FN = 10 kg			
Vw	h	rxP	rxW	rB
[kt]	[m]	[m]	[m]	[m]
0	20,00	10,00	0,00	10,00
5	19,32	9,66	5,18	14,84
10	13,63	6,82	14,63	21,45
15	7,66	3,83	18,48	22,30
20	4,54	2,27	19,48	21,75

Table 10 – Buffer radius (L = 40 m)

L = 40 m	FN = 10 kg			
Vw	h	rxP	rxW	rB
[kt]	[m]	[m]	[m]	[m]
0	40,00	20,00	0,00	20,00
5	38,63	19,32	10,37	29,69
10	27,25	13,63	29,28	42,91
15	15,30	7,65	36,96	44,61
20	9,08	4,54	38,96	43,50

Table 11 – Buffer radius (L = 100 m)

L = 100 m	FN = 10 kg			
Vw	h	rxP	rxW	rB
[kt]	[m]	[m]	[m]	[m]
0	100,00	50,00	0,00	50,00
5	96,54	48,27	26,08	74,35
10	67,93	33,96	73,39	107,35
15	38,10	19,05	92,46	111,51
20	22,61	11,30	97,41	108,72

Table 12 shows the parameter of the equivalent sphere and the retention cable ultimate wind load.

Table 12 – Retention cable ultimate wind load

FN	ds	S	VW
[kg]	[m]	[m ²]	[m/s]
10	4.20	13.92	31.0

The following table summarize the aerodynamic drag due to different wind conditions and for three different lengths of the retention cable $L = \{20,40,100\} [m]$ and for a net thrust (FN) of 10 kg.

Table 13 – Aerodynamic drag of the equivalent sphere for different wind speed (L = 20 m)

L = 20 m	FN = 10 kg		
Vw	dS	S	FW
[kt]	[m]	[m]	[N]
0	4.21	13.92	0
5	4.21	13.92	32

10	4.21	13.92	130
15	4.21	13.92	292
20	4.21	13.92	519

Table 14 – Aerodynamic drag of the equivalent sphere for different wind speed (L = 40 m)

L = 40 m		FN = 10 kg	
Vw	dS	S	FW
[kt]	[m]	[m2]	[N]
0	4.21	13.92	0
5	4.21	13.92	32
10	4.21	13.92	130
15	4.21	13.92	292
20	4.69	17.28	520

Table 15 – Aerodynamic drag of the equivalent sphere for different wind speed (L = 100 m)

L = 100 m		FN = 10 kg	
Vw	dS	S	FW
[kt]	[m]	[m2]	[N]
0	4.21	13.92	0
5	4.21	13.92	33
10	4.21	13.92	131
15	4.21	13.92	295
20	4.69	17.28	524

COMMENTS AND CONCLUSIONS

According to Table 4, for the non-critical scenario, the reciprocal of the maximum acceptable probability is lower than the reliability accepted for this kind of aircraft. Thus, operations are allowed for every RPAS considered in this analysis.

The application of mitigation factors, such as probability of fatality and probability factor that RPAS may crash in a specific area, increase the maximum acceptable probability of the (FAA, 2000) method. According to Table 5, Table 6 and Table 7, the flight operations of MH850, AGRI-200 and Q4L are safety in that scenario, while for the Q4P (Table 8), sector 1 and 2 exceed the minimum reliability accepted for this kind of RPAS. Thus, a restriction of the area of operation has to be considered, as shown in Figure 13. Flight operation of Q4P are allowed only in the dashed red area.

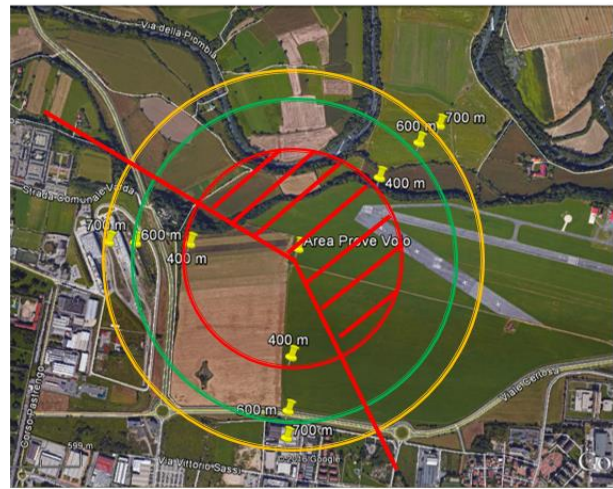

Figure 30 Restriction of the area of operation for the Q4P

In the lighter than air unpowered blimp exercise, a buffer radius that varies as a function of the length of the retention cable has been defined (cleared area):

- L = 20 m, buffer radius: rB = 23 m
- L = 50 m, buffer radius: rB = 46 m
- L = 100 m, buffer radius: rB = 114 m

Operations should be limited, according to the wind speed. In particular operations are allowed if the wind speed do not exceed 15 kt. As a comment, the present risk assessment methodology can be extended also to powered lighter than air vehicles where the tether is removed and a line of sight radial distance is considered for the definition of the cleared area.

ACKNOWLEDGMENT

The work here proposed is within the activities of the S-APR project, funded by the Autonomous Province of Bozen, Italy.

REFERENCES

- [1] Dalamagkidis K., Valavanis K.P., Piegler L.A., 2011. On Integrating Unmanned Aircraft Systems in to the National Airspace Systems, Springer, Mar. 2011
- [2] EC, 2008. Regulation (EC) No 216/2008 of the European Parliament and of the Council, 2008.
- [3] ENAC 2013. Regolamento Mezzi Aerei a Pilotaggio Remoto, 1st Edition, 16th December 2013.
- [4] ENAC, 2015. Remotely Piloted Aerial Vehicles Regulation - Issue No. 2, Rev. 1, 2015.
- [5] EASA, 2015. Introduction of a regulatory framework for the operation of unmanned aircraft.
- [6] EASA, 2016. Prototype Commission Regulation on Unmanned Aircraft Operations. 22th August 2016

- [7] FAA 2000. Expected Casualty Calculations for Commercial Space Launch and Reentry Missions, FAA-AC431.35.
- [8] FAA, 2015. Unmanned Aircraft Systems (UAS) Registration Task Force (RTF) Aviation Rulemaking Committee (ARC), «Task Force Recommendations Final Report», November 21, 2015
- [9] G. Guglieri, A. Lombardi, G. Ristorto, 2015. “Operation Oriented Path Planning Strategies for RPAS”. In American Journal of Science and Technology, vol. 2 n.6 pp. 1-8
- [10] G. Guglieri, F. Quagliotti, G. Ristorto, 2014. “Operational Issues and Assessment of Risk for Light UAVs”, Journal of Unmanned Vehicle Systems, Canadian Science Publishing (NRC Research Press), pp 11, pagine 119-129, ISSN: 2291-3467.
- [11] Shelley, A. V., 2016. A Model of Human Harm from a Falling Unmanned Aircraft: Implications for UAS Regulation. International Journal of Aviation, Aeronautics, and Aerospace, 3(3). <http://dx.doi.org/10.15394/ijaaa.2016.1120>

AUTHOR INFORMATION

Giorgio Guglieri, Professor, Dipartimento di Ingegneria Meccanica e Aerospaziale, Politecnico di Torino, Italy.

Gianluca Ristorto, junior engineer technical specialist, Mavtech srl, Bozen, Italy

THE IMPACT OF SAFETY AND SECURITY STANDARDS ON COMFORT IN BUSINESS AVIATION

Ing. Júlia Hankovská

ABS Jets, Czech Republic

julia.hankovska@gmail.com

Assoc. prof. Benedikt Badanik

Air Transport Department, University of Zilina, Slovakia

benedikt.badanik@fpedas.uniza.sk

Abstract - Aim of this article is to evaluate the impact of safety and security standards on comfort in business aviation. The comfort that the article is focusing on is not only related to cabin layout and luxury furniture. The comfort factors in focus are related to services, operation capacity, and flexibility of last minute flights and reliability of business aviation services. Main section of the article covers current situation in the business aviation market in Europe. Next part of the article offers an insights into the impact of safety and security standards on improvement of clients comfort. It explains contradictions between what is allowed by safety and security standards and what is required by clients. Final part of the article outlines the possibilities of how to increase the level of comfort factors and respect all the safety and security standards at the same time.

Key words - business aviation, safety and security standards, comfort factors

INTRODUCTION

Business Aviation is small but inevitable part of air transport industry and it is by nature secure and private. The annual number of Business Aviation clients carried by European operators is around 3,5 million while number of clients of commercial airlines is around 800 million as it is shown by the following graph.

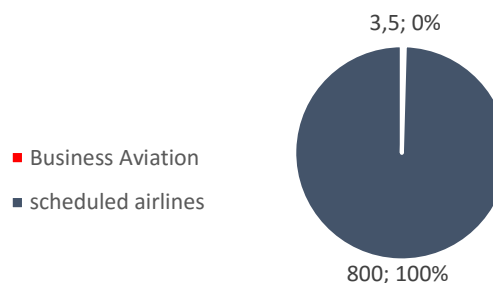

Graph 1: Business Aviation passengers annually in Europe compared to passengers of scheduled airlines (in million) (EBAA)

Beginning of the paper offers clarification of the term “comfort in business aviation”. The comfort is generally defined as “a cause or matter of relief or satisfaction”. It is not affected only by physical features of airline product e.g. furniture and cabin layout. Comfort in business aviation is also related to the services, flexibility of flights, aircraft capacity and the crew duty.

This paper offers a clients’ point of view on safety and security issues in business aviation.

This paper considers business aviation as an “on demand operations of aircraft in VIP configuration with increased comfort and extra on board services”.

Number of passengers using business aviation services is rather limited but the number of destinations they require transportation to is rather big. As business aviation travellers require swift transportation services, with no delays, the closest airports must be chosen. They cannot afford lengthy transfers or lost baggage, therefore they prefer small airports which are not used as bases by many big airlines. Business aviation allows them to enhance their productivity, make efficient use of their time and money, and in return add real value to local and national economies.

The comfort which is expected by clients who decided to use business aviation services means to put minimum effort but to get maximum of satisfaction.

Whole process starts in moment when client needs to get from one point to another.

Next part of the paper presents the way the passengers use business aviation services. The best scenario is to set the date and destination and operator will take care of everything else, client just comes to the airport, board an aircraft and travel to his/her final destination, where he/she gets off of the aircraft and does not take care about anything else.

Provision of business aviation services is limited by numerous internal, national or international regulations.

SAFETY AND SECURITY REGULATIONS IN AVIATION

Operators mostly operate small aircraft, with maximum take-off weight (MTOW) up to 45 tonnes and with a maximum seating capacity of 19 seats.

Security advantage of small aircraft is less people. Less potential danger of terrorism or other conflicts between people on board. Due to small number of seats, aircraft are more comfortable and people feel calm and relax. The size of aircraft also influences its capability to cause damage on the ground. The bigger the aircraft, the greater the damage and the greater the attraction for hijacking and for unlawful acts.

As far as business model is taken into account, business aviation are frequently operated as charter flights. Ownership of aircraft is usually fractional. Most of flights are private (corporate or leisure) not general public flights. It limits also risk of terrorism or public threat.

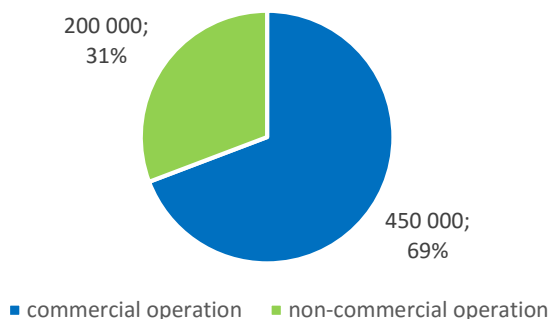

Graph 2: Number of airport movements in Europe (EBA)

700 000 business aviation airport movements in EU per year, around 450 000 are operated commercially (for remuneration), 250 000 non-commercially, mostly by corporations operated as business-supporting flights. Only 3-4% of the non-commercial flights are by individuals who fly for private reasons (including leisure flights).

Business aviation operators offer and sell flights, not seats. Individual tickets are not sold. In practice that means that

passengers know each other. It is not group of unknown people who are going to stay few hours together on board.

Nowadays the needs and wants of business aviation passengers are very specific. They would like to have as much comfort and flexibility as possible. They are however required to follow all different kinds of specific requirements.

This paper focuses on some of them, e.g. screening, security checks etc.

According to the regulation EC 300/2008, all departing passenger shall be screened by Walk-Through-Metal-Detection equipment. If the alarm is activated the person shall be required to be screened one more time or searched by hand. Even owners of aircraft must complete the security check. Also the cabin baggage of all departing passengers shall be screened prior to being allowed into security restricted areas and on board of an aircraft.

Even diplomats must undergo all security procedures.

The lack of communication skills of security staff and misunderstanding of the business aviation model, often cause a poor customer services.

If the passengers transfer from one country to another the customs check is necessary. Some airport require the passengers out of the aircraft. For business aviation passengers it is another complication. Business passengers prefer customs officials boarding the plane after landing and doing the check on board aircraft.

Another regulation which impact the business aviation operation is slot coordination. Main reason of slot coordination even the airport or ATC slots is to effectively use airport capacity and air space (the paper considers EU air space) and another reason is to provide air transportation services as safe as possible.

However, for the Business Aviation it means great time limitation, which could affect passengers' schedule.

Even for the purposes of slot allocation and grandfather rights - airlines using the slots in one season may claim them in the following season. This also applies to business aviation operators, but only if they operate schedule flights. For most of business aviation operators it is almost impossible to acquire grandfather rights.

Related to safety there are also crew limits – flight time limitations, which must be observed if the flight is commercial. For the flights with private status more tolerable rules are applied. The question is whether it is safe enough.

COMFORT VS. SAFETY AND SECURITY - INNOVATION

The main objective of this paper is to find the way how to innovate business aviation services with a view to increase capacity and reliability of business aviation flights while meeting all requirements related to safety and security.

Client has always been top priority for business aviation. And the most important aim of this sector of aviation is to satisfy all his/her needs with a view to keep his/her loyalty.

In some cases client does not even know what his/her specific needs are. Customer care department assists the client in specification of his/her particular needs and travel arrangements.

This paper focuses on increased security of business aviation services. The question is how to meet increased security requirements and keep up with the requirement for increased comfort.

European Business Aviation Security idea

If the authorities knew the owners of aircraft or frequent flyers, it could be possible to make security processes much faster.

As previous graph 2 shows, there are not so many passengers using the business aviation services.

One of the suggestions is to make a business aviation security clients database (for geographic area, for example for Europe or it could be bigger), which will include people who fly by their own aircraft or frequently fly with for business. The idea is similar like for the airport staff. Clients will be checked by operator. Operators know their repeating customers and they will be able to add people to the business aviation client list. Of course even operators must be authorised to do that. The condition for authorisation would be strict and operator would have a safe history of operation.

The airports must also be authorised. The area of business aviation would be marked and separated from other parts of the airport. For example at the Prague airport there is terminal 3 dedicated for general and business aviation. It would be a good candidate to get business aviation security authorisation.

Handling providers taking care of business aviation flights will need to be better trained and authorised for taking care of such clients. The handling agents will have also security training especially created for them.

Simplified draft of this security project, let's say European business aviation security, will focus on operators, handling agents and airport authorities. The certified operators will consecutively build a business aviation community of frequent flyers and travelling will become much easier and faster for these people.

Their journey could then look like this:

- they will come at the airport and meet with handling agent who will be security trained and will properly know the client
- client will simply and smoothly get to the aircraft which will be ready to fly

The idea may seem to be complicated but after difficult beginning it could bring another advantage for business aviation. It could increase value of business aviation and the most important to rise the comfort level of clients.

The price for this service could be part of VIP handling price, definitely it will be a little bit higher, especially due to security training of handling agents, but according to our experience the business aviation clients are willing to pay more for services which help them to get to their destination faster. This consideration

supposes the higher costs in the beginning, until the project will be implemented and tested, but from the point when the database will be mostly created and procedures set for the most secure operation, than costs will be reduced.

Very similar idea was recently tested at some airports across Europe. The benefit of flying without security check was only for aircraft owners. There was the obligation of operator to inform the airport about these passengers. Our idea is simpler because all involved certificated institutions like operator, handling agent and airport will have an access to the database and they could very quickly check the passenger only through ID. But it will not be necessary for the handling agent to know the client. He will wait for him in the airport hall and escort him to the aircraft.

The second step could be the use of business aviation security database also for customs purposes. If the database includes all necessary information, it will also increase the effectiveness of customs office at the airports.

Comfort of clients will remain as high as possible and all the security requirements will be met.

Business Aviation Slots

Another suggestion how to make business aviation more reliable is to increase daily aircraft utilisation through usage of the slots.

As indicated earlier, business aviation usually uses smaller airports which are not slot coordinated, but sometimes there is no other option. Again Prague could be taken as an example Prague, where the main airport is also the closest airport to city centre.

It is the most suitable airport for clients. Airports usually record number of business aviation movements, arrivals or departures. Base on this data the most appropriate slot could be chosen. Each airport has its own data according to which it would be possible to coordinate business aviation slots.

They can be accommodated in current system of airport slots. There are three different categories of slots to be used: ad-hoc, short or invisible slots.

Short slot will be shorter than usual slot, therefore it will not cause big delay for the rest of operation and it will be applicable for instance each hour.

In practise it could look like this:
 - the airport will set few hours (according to the historical data) which will have an ad-hoc slots. Each hour one slot.

- Business Aviation operator will be offered to choose the invisible slot within one hour after his request.

9:00	9:15	9:30	9:45	10:00	+ quick slot
5	5	5	5	5	1

Picture 1: Example of slots planning

-the invisible slot guarantees a take-off in specific time frame (within 5 minutes). Invisible because the rest of operation will not even notice this slot.

If the operator will not use this slot, he must ask for proper available slot.

This solution could affect the commercial operation but if it is set properly, it will affect commercial operation just slightly.

CONCLUSION

This paper is focused on increasing of business aviation reliability from clients' point of view. It offers options to increase comfort of business aviation clients.

Both considerations would need an in-depth research.

It is interesting to see that operators keep on improving their services for clients and they are able to keep up with more demanding safety and security standards.

Increased reliability brings improved business aviation services and satisfaction of clients.

REFERENCES

- [1] EBAA websites (various articles)
- [2] Business Aviation in Europe, Michal Pazourek
- [3] COM/2015/0599 final
- [4] REGULATION (EC) No 2320/2002
- [5] Regulation (EC) No 300/2008
- [6] COMMISSION REGULATION (EU) No 1254/2009
- [7] Regulation (EU) No 952/2013
- [8] Regulation (EEC) No **95/93**
- [9] Regulation (EC) No **545/2009**
- [10] Aviation: Airport Slots, Louise Butcher, 2012

PUBLIC SERVICE OBLIGATION ON EU AVIATION MARKET

Martin Hromádka, PhD.

Air Transport Department, University of Žilina, Slovakia

hromadka@fpedas.uniza.sk

Filip Škultéty, PhD.

Air Transport Department, University of Žilina, Slovakia

skultety@fpedas.uniza.sk

Abstract - The paper deals with public service obligation as one of the forms of state aid. Various quantitative parameters of public service obligation utilization within EU member states are analysed. Moreover, paper summarises focuses on economic aspects of public service obligation in European Union, especially levels of subsidies in particular member states.

Key words – Analysis, Imposed Routes, Public Service Obligation.

INTRODUCTION

Historically, liberalisation in EU markets as a significant milestone in air transport market history meant not just breakthrough in terms of market access but it also brought new elements of protectionism to the system. One of them was state aid, to use “modern” vocabulary. In the airport business, states tried to benefit their airports by giving them all kinds of operation aids. In this situation, the Commission had to react promptly, because without its intervention, this situation could disrupt the process of liberalisation. Based on these facts, the Commission developed guidance and rules regarding the application of state aid in air transport. Currently, according to the Commission rules and guidelines, there are several forms of state aid, which are addressed either for construction and operation of airport infrastructure or for users of airport infrastructure.

One of the forms of state aid is so called public service obligation (PSO). According to [1], PSO is defined as a form of service of general interest in which a state can subsidize an air connection. State can impose a PSO to ensure the adequate provision of scheduled air services to a peripheral or development region or on a thin route to any regional airport that is considered vital for the economic development but is not commercially viable.

To assure principles of equality and non-discrimination, EU unify conditions of state aid for subsidising air services under regulation 1008/2008. Each member state decides which routes are considered as essential and will be covered under PSO scheme. This paper deals with recent development in terms of quantitative usage of this kind of subvention.

TREND OF IMPOSED PSO ROUTES

Since introducing PSO in 1993, one can witness different approaches in terms of using PSO by EU member states. There are states that imposed a various routes under PSO scheme on one hand, while on the other, there are states that have not imposed any or only few routes under this regulation.

Since there is no database of imposed PSO routes, the trend of imposed routes will be assessed from data given by the Directorate-General for Mobility and Transport of the European Commission. Author was provided with data form 2013 and 2015.

Table 1 – PSO routes imposed in 2001, 2007 and 2013 - 2015 (Source – Official Journal of European Union)

	2001	2007	2013	2014	2015
Estonia	x	0	0	4	4
Czech Republic	x	0	3	0	0
Croatia	x	x	0	0	10
Cyprus	x	0	0	0	1
Finland	0	4	3	3	3
France	46	73	58	42	45
Germany	5	3	3	0	0
Greece	0	25	31	28	28

Ireland	5	7	7	3	3
Italy	6	31	41	20	22
Portugal	10	27	25	24	21
Spain	10	16	18	18	18
Sweden	1	11	11	10	10
United Kingdom	12	26	21	22	22
Iceland	1	7	7	0	0
Norway	61	40	62	51	51
Total	157	270	290	225	238

x – not a EU member at particular year

The number of routes operated in Europe under PSO contract has been growing more or less consistently throughout the selected period. In 1997, there were 67 PSO routes, 157 PSO routes in 2001, 230 routes in 2003 and 270 were imposed in 2007. In the recent history, the biggest numbers of imposed routes were in 2013 (total of 290 routes). In 2014 and 2015 one can see a slight decline with 225 and 238 routes respectively. All numbers include routes imposed in Norway and Iceland. These states are not member states of EU, but are members of EAA and when it comes to PSO routes, they are under same regulation as EU member states. [2]

One important fact that needs to be mentioned is that these numbers involve imposed routes only. In reality, the number of active routes with assigned operator is lesser. Many of imposed routes are being repealed or had unsuccessful tenders.

When comparing list of imposed routes in 2013 and 2015, one can see that some routes were successfully prolonged, new routes were imposed and some ended their operation. In 2015, 10 new routes were imposed by the newest member of European Union – Croatia four more were imposed by Estonia and one by Cyprus. On the other hand, three routes have not been prolonged due to unsuccessful tender in Czech Republic. Three routes in Germany ended their contract in 2013 and were not prolonged for years to come. In France, Italy and Portugal, several routes ended their service by 2015.

When comparing how PSO routes are used by “original” and “new” (joining EU in 2004 or later) member states of EU, the most routes are imposed in “original” member states. Only Austria and Benelux countries have never imposed PSO routes, probably due to sufficient access to air transport within their territory. On the other hand, far more “new” member states have never imposed any routes.

ANALYSIS OF PSO ROUTES IN 2015

In 2015, only 12 EU countries plus Norway imposed routes under PSO scheme. Complete list of current routes from official journal of EU as for December 2015 can found in Appendix A. Official journal briefly informs of country which imposes route, airport concerned, validity of PSO, geographical designation, type of market access, operating

airlines or airlines previously operating on particular route. Map of PSO routes in 2015 can be found in Figure 1.



Figure 1 – Map of PSO routes imposed within EU in 2015

I. PSO by designating country

Number of PSO routes by designating country can be found in Figure 2.

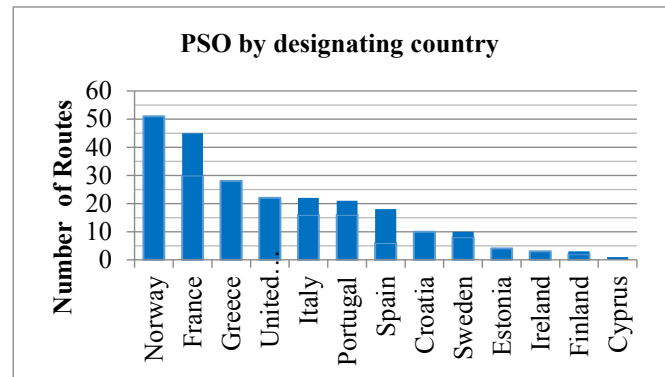

Figure 2 – PSO routes by designating country – 2015

(Source : Official Journal of European Union)

In 2015, Norway had the largest number of PSO routes among selected countries, 51 in total. Within EU, France had the largest number of imposed routes, as much as 45. France is followed by Greece with 28, United Kingdom and Italy both having 22 routes, Portugal had 21 and Spain 18 of those routes. Other member states imposed 10 or less routes.

II. PSO by market access

One of the ways in which PSO imposition can be classified is according to the market access to potential operators. It can be either restricted or open:

1. Open access to all EU carriers with specified service levels such as frequency, aircraft size or maximum prices.
2. Restricted access with a tender, which means that only one air carrier will operate that particular route after a successful tender process. Restricted access can be provided with or without a financial compensation.

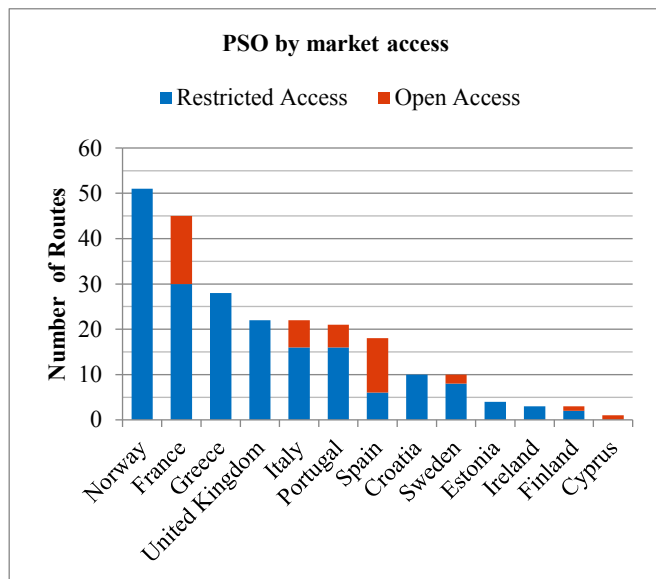

Figure 3 – PSO by market access – 2015 (Source : Official Journal of European Union)

Whether the market access will be restricted or open, is a responsibility of the administering authority of each member state. Figure 3 represents proportion of routes with restricted respectively open market access.

In the most states, restricted market access prevails. In Norway, Greece, United Kingdom, Croatia, Estonia and Ireland are all routes designed so that only one carrier will be selected after tender process to operate particular route. In France, only routes connecting French overseas territories and four routes within French mainland have open access to all carriers. In Portugal, restricted market access prevails as well; four routes with open access connect Lisbon with airports at Azores Islands and Madeira. Spain is the only country with prevailing open market access to PSO routes with two third of routes under this type of contract.

III. PSO by geographical type

PSO routes can be divided according to geographical area to three categories. This typology specifies if the route connects mainland, island or outermost territory. Routes with this type of division can be found in Figure 4.

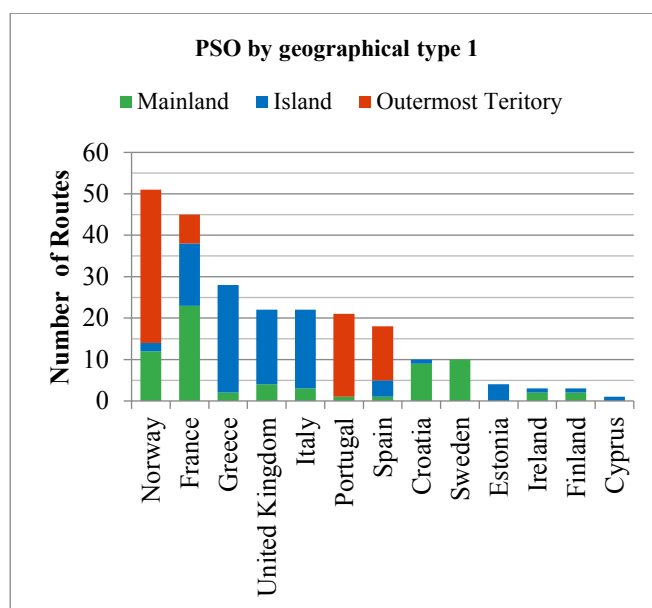

Figure 4 – PSO by geographical type – 2015 (Source : Official Journal of European Union)

Figure 4 shows typology of routes according to geographical type defined by the Commission. In Greece, United Kingdom and Italy, there are island routes dominating, while in Croatia and Sweden, there are only mainland routes imposed. The specific situation is in France, Portugal and Spain, where French overseas territories, Azores Islands, Madeira and Canary Islands are considered as outermost territories. In France, the majority of routes are mainland connections, while only seven routes connect French overseas territories. In Portugal and Spain, the vast majority of routes are connection to and within Azores and Canary Islands.

As this distribution of routes does not give a real picture whether the route is a connection between an island and mainland or island and island, I divided routes to four categories: (1) routes connecting airports in mainland, (2) routes between mainland and island, (3) inter island routes and (4) international routes. Routes with this type of division can be found in Figure 5.

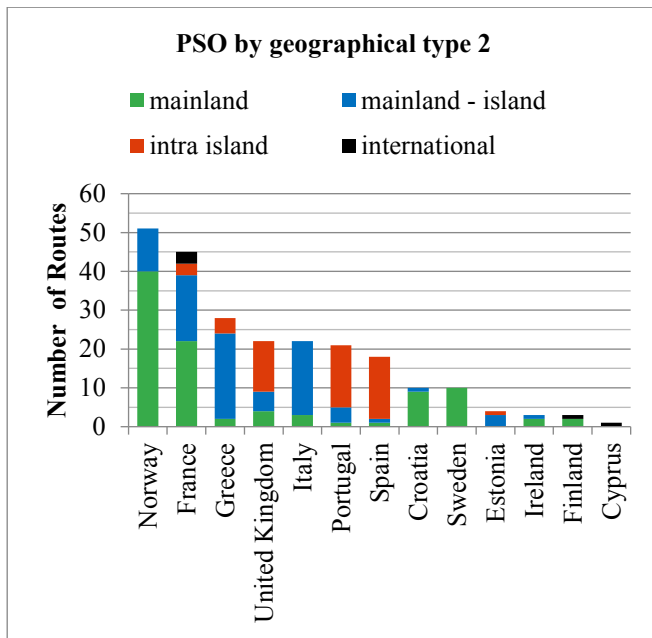

Figure 5 – PSO by geographical type – 2015 (Source : Official Journal of European Union)

This selected typology shows that the majority of routes in Norway are connections between mainland airports. However, these connections are mostly between sparsely populated north areas of Norway. In France, the distribution is more diverse. Three routes between Strasbourg and Amsterdam, Madrid and Prague are with international status. Another three routes connect islands of Guadalupe in Caribbean. Routes marked as a mainland – island connection are mostly consisting of routes between Corsica and French mainland. This group also contain four routes between Paris and French overseas territories (Guadalupe, Martinique, Reunion and French Guyenne). Remaining 22 routes are connecting airports in French mainland, with five mainland routes in French Guyenne. In United Kingdom, the majority of PSO routes are inter island connections in Scotland. The similar case is observed also in Portugal and Spain, where vast majority of routes are intra island connections in Azores, Madeira, Canary and Baleares. Finland has one international route from archipelago Aland to Stockholm. Route is established to connect Swedish population of Aland archipelago to Sweden.

IV. Share of PSO traffic on domestic traffic

PSO routes in Estonia and Ireland counted about 90 per cent of total domestic traffic in 2014. This high share is caused by small geographical area and small portion of domestic routes. In case of France and Portugal, one can see how widely they use their PSO routes in domestic services. In Italy and Greece, the share is slightly more than 9 % and PSO routes

are quite important in these countries. In United Kingdom, Sweden and Finland, the share of PSO routes is relatively insignificant. Share of PSO traffic on domestic routes in 2014 can be found in figure 6.

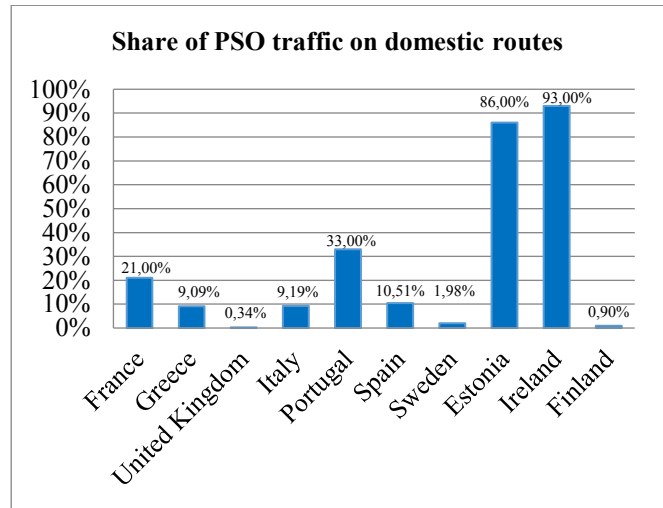

Figure 6 – Share of PSO on domestic traffic – 2014 (Source : Official Journal of European Union)

V. Number of passengers carried on PSO routes

Number of passengers (PAX) carried on PSO routes in 2014 can be found in Figure 7. France, which has the largest number of PSO routes, carried the biggest number of passengers on their PSO routes. In case of Greece, one can demonstrate that with the 28 PSO routes operated, the country carried less than half a million passengers. It is caused by a fact that these routes are operated with relatively small aircraft with seating capacity in average about 50 seats. Also, the frequencies are also lesser compared with routes in Italy or Spain. In United Kingdom, the majority of routes in Scotland are operated by small aircraft with average seating capacity of 14 passengers. Despite of relatively high number of operated routes, the number of carried passengers is slightly more than 71,000.

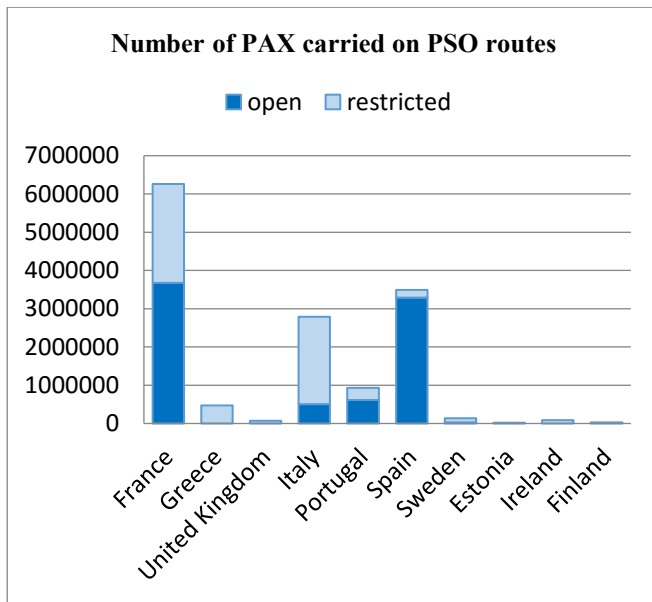

Figure 7 – Number of PAX carried on PSO routes – 2014
(Source : Official Journal of European Union)

VI. Service level characteristics

PSO contracts differ from fixed conditions and level of service required. By comparing the content of contracts between countries, there are prevailing features typical for each country. Service level summary characteristics can be found in Table 2.

Table 2 – Service level summary characteristics of PSO by Country [4]

Country	Minimum service frequency	Minimum seating capacity	Minimum aircraft size	Timetabling requirements
France-Corsica	All routes	Most routes	All routes	Most routes
France-Mainland	All routes	Some routes	All routes	Most routes
Ireland	All routes	All routes	Yes	All routes
Italy	All routes	All routes	All routes	All routes
Norway	All routes	All routes	Yes	All routes
Portugal	All routes	Most routes	Most routes	Some routes
UK	All routes	Some routes	Yes	Some routes
Spain	Some routes	All routes	No	Most routes
Sweden	All routes	All routes	Most routes	Some routes

Almost all contracts require minimum service frequency except of few routes in Spain. Majority of contracts specify minimum aircraft size required on particular route. This is not the case in Spain where the minimum aircraft size is not required, but to assure adequate level of offered seats, they specify minimum seating capacity per route, which needs to be complied.

VII. Amount of PSO subsidy by country

Amount of subsidy from national authorities given for establishing or maintaining PSO route is always the crucial part of the contract.

In France the average subsidy paid by passenger is in average of 40 EUR per passenger except the case of routes in French Guyana, when the compensation is almost four times higher. In case of three routes in Scotland, the average subsidy is also a bit higher – 88 EUR comparing to the average amount in Greece, Norway, Ireland or Finland.

The amount of subsidy given represented by region/country can be found in Table 3.

Table 3 – Service level summary characteristics of PSO by Country [4]

Area	Number of passengers	Public compensation (EUR)	Average subsidy (EUR per passenger)
Metropolitan France (2014)	386,482	24,404,000	63.14
Strasbourg - Madrid, Amsterdam, Prague (2014)	89,452	3,601,000	40.26
Corsica (2014)	2,090,777	75,000,000	35.87
French Guyana (2014)	37,155	5,474,000	147.33
Scotland, Glasgow - Tiree, Barra, Cambeltown (2009)	25,000	2,200,000	88.00
Greece (2011)	620,000	31,000,000	50.00
Norway (2014)	1,718,750	110,000,000	64.00
Ireland (2009)	223,695	12,360,000	55.25
Finland (2014)	24,648	2,800,000	46.59

CONCLUSION

Public Service Obligations in Air Transport exist to overcome a failure to perform a regular air service on some specific routes in a liberalised market. The Government wants to assure that an essential service is provided in a liberalised market where air carriers have no interest in

providing such service. It is considered as a form of state intervention, which is allowed and do not distort competition.

PSO scheme is very important topic for European Commission. This is supported by the fact that EU marked PSO regulation in new aviation strategy for Europe as a key feature. In Europe not many regions have an acceptable level of air transport services, that is why the European Commission is presenting a PSO scheme as a way how to ensure service to and from under-served regions. The applicable conditions in regulation 1008/2010 were conducted in 2011 – 2013, so that PSO rules deemed to fit its purpose. The Commission is to publish guidelines explaining the current rules governing PSO in 2016 to add this regulation added value. [8]

REFERENCES

- [1] GORDIJN H., VAN DE COEVERING P., 2006. Aviation as public transport: which regions are underserved? Netherlands Institute for Spatial Research, [online]. Available on the Internet: <http://abstracts.aetransport.org/paper/download/id/2330>
- [2] MINSHALL C., 2004. Use and Reform of the Public Service Obligation MSc thesis, Cranfield University
- [3] TOMOVÁ A., 2015. Are commercial revenues important to today's European air navigation service providers? In: Journal of air transport management. - ISSN 0969-6997. - Vol. 54 (2016), p. 80-87.
- [4] Moderation and elaboration of PSO/RDF. Application guidelines and study on regional economic justification of PSO/RDF, 2013. UNICONSULT Universal Transport Consulting GmbH, [online]. Available on the Internet: <https://www.google.sk/url?sa=t&rct=j&q=&esrc=s&source=web&cd=9&cad=rja&uact=8&ved=0ahUKEwiSw9eHpcfMAhVJfRoKHUTsBHAQFghcMAg&url=http%3A%2F%2Fwww.baltic-bird.eu%2Fservices%2Fdocuments%2Fcategory%2F45-results%3Fdownload%3D437%3Afinal-report-task-a-moderation-and-elaboration-of-pso-rdf-guidelines-workpacks-1-3-1-4&usq=AFQjCNGYlyg2CQz3i9LX2Tssj5eoQeXVqg>
- [5] NOVÁK A. et al. 2015. Airlines in Poland. In: Transport and communications : scientific journal. - ISSN 1339-5130. - No. 2 (2015), s. 17-21.
- [6] ROCQUE E., 2015. Presentation of the policies and regulations put in place in France and Europe, in order to develop regional routes, French civil aviation authority, [online]. Available on the Internet: <http://www.slideshare.net/aviacaocivilgovbr/secretaria-de-aviao-civil-ps-os-in-france>
- [7] KJAELAND F. MATHISEN T.A., 2012. Assessing the peripheral status of local airports. Journal of Air Transport studies, [online]. Available on the Internet: <http://etem.aegean.gr/files/jats32.pdf> ISSN: 1791-6771
- [8] KJAELAND F. MATHISEN T.A., 2012. Assessing the peripheral status of local airports. Journal of Air Transport studies, [online]. Available on the Internet: <http://etem.aegean.gr/files/jats32.pdf> ISSN: 1791-6771

ACKNOWLEDGEMENT

This paper has been created following the project in the process of solution which has been co-financed by the EU sources entitled „ Centre of Excellence for Air Transport Centrum- ITMS 26220120065.“



AUTHOR INFORMATION

Martin Hromádka, Lecturer, Air Transport Department, University of Žilina.

Filip Škultéty, Lecturer, Air Transport Department, University of Žilina.

LOW COST MARKET EVOLUTION – EDIFICATION FROM THE PAST, VISIONS OF FUTURE

Prof. Antonín Kazda

Air Transport Department, University of Žilina, Slovakia

kazda@fpedas.uniza.sk

Mária Mrázová

Air Transport Department, University of Žilina, Slovakia

mrázová@fpedas.uniza.sk

Abstract - This paper offers an analysis of the existing low-cost carrier business models, describes their historical evolution and predicts their future modifications in order to stay profitable in a fast changing environment. Air traffic is growing rapidly and therefore it is necessary to consider the major factors that influence the development. Following the trend of passengers' travel demand, it was identified that quality of services had become the paramount indicator while ticket price was progressively receding behind the scene. Cutting costs had become a continuous and long-term necessity for financial success in the airline industry. In spite of the fact that legacy airlines have adopted some strategies similar to low-cost carriers, they still were not able to match cost efficiencies in the same way as low-cost carriers. This paper presents a new airline product typology. We research where airline product is moving and point to similar examples from other business sectors and history. We also assess the future trends of low-cost carriers' business model development.

Key words - Low-cost carriers, legacy airlines, business models, future trends.

BACKGROUND

Development and fast growth of air transport after the WWII were controlled by strict IATA and governments regulations. International air services were regulated by enormous amount of bilateral agreements (Button, 2009) that included the control of stopovers, routes, frequencies, capacities and even on-board services like amount and quality of food and drinks. For legacy airlines, the situation has changed since deregulation which first started in the USA in 1978. Before

the deregulation the legacy carriers were in a monopoly on aviation market and suddenly new competitors with different strategies have appeared. The deregulation of transport was a revolution¹⁰ with significant impacts not only on air transportation but also on society and economy.

Low-cost airlines have become an increasingly global phenomenon that has dramatically reconfigured route patterns, processes, customer expectations and flight experience. These airlines are also known as *no-frills*, *discount* or *budget carriers* and concentrated themselves on lower fares, and lower level of comfort or extent of offered services compared to legacy carriers. Deregulation and liberalization processes were the first indicators that lead to the low-cost airlines' entrance on the aviation market.

Case studies related to the low-cost airlines have shown that the original Southwest Airlines concept has been a major inspiration to other low-cost carriers, and its business model has been repeated many times around the world (Bamber, G.J., 2009). The competitive strategy combines high level of employee and aircraft productivity with low unit costs by reducing aircraft turn around time particularly at the gate . Also, many low-cost typologies were presented, but none of them was aimed at a level of offered services, even though the low-cost airline product recently shows many improvements. Market saturation forced low-cost carriers to look at other ways of expansion as the orientation only on price-sensitive customers has become insufficient. Low-cost carriers had to offer a '*best match product*' as a reaction to

¹⁰ A revolution (from the Latin *revolutio*, "a turn around") is a fundamental change in political power or organizational structures that takes place in a relatively short period of time when the population rises up

in revolt against the current authorities. (<https://en.wikipedia.org/wiki/Revolution>; retrieved 9.10.2016)

competitive environment. The new typology of airline models is based on the market evolution since the deregulation and predicts how airlines' business model can evolve.

LOW-COST AIRLINE BUSINESS MODELS

European airline industry is highly dynamic, competitive and has gone through many changes. The term *low-cost airlines* is often used for carriers if they have homogeneous operations that lead to reducing operational costs as much as possible. However, there are variations of the business model, as well as significant diversities between airlines (Calder, 2002); (Gillen, Morrison, 2003). Nevertheless, the success of LCCs has not risen from market deregulation alone. Liberalisation played notable role, but it was not sufficient condition for the spreading of the LCCs. Other significant catalysts that supported the entry of low-cost airlines in the aviation market include entrepreneurship, population, airport availability, or price transparency. The typical LCCs profile could be described by three key components: product, market positioning and operating costs (see Table 1).

Table 1 Low-cost airline business model components
(Source: Mrázová, M., 2016)

Simple Product	Positioning	Low Operating Costs
Product based on no free services on-board	Focusing on non-business PAXs + leisure traffic	Lower airport fees, lower costs for maintenance because of new fleet + homogeneous fleet
Narrow seating due to greater capacity + free seating	Point to point traffic on short haul + high frequencies and usage of secondary airports	Lean sales based on high percentage of online sales
No Frequent Flyer Programmes (it is not a rule)	Aggressive marketing strategies	Quick turnarounds (boarding processes, no air freight, no hub/spoke services...)

However, we can find differences in business models even between the 'pure' low cost airlines. For example, the Southwest aimed at cutting down operating costs and allocating itself only on profitable routes (Gittell J, 2003), (Taneja N., 2014). Southwest grew by offering a simple product – low fares that were designed to compete with the prices of automobile or bus transport, rather than with other airlines. Southwest is also known for quick turnarounds to minimise time on the ground and high

percentage of the load factor. It concentrated on four basic features that were expected as the core airline business, focused on reduction of delays, complaints, mishandled bags and pilot deviations. Southwest's success was driven by the right choice of a product – reliable low-cost travel. The product simplicity was represented just by a good service, a good fare and being in the destination on time.

The success of Ryanair was based on stimulation of demand, particularly from fare-conscious leisure but also business travellers. Also, they set fares on the basis of the demand for particular flights. All of this is linked with the concentration of Ryanair on the lowest possible operational costs on one side, and maximum ancillary revenues on the other side. In addition, in 2014 Ryanair's revenue model consisted of 58% core revenues, 20% subsidies and 22% ancillary revenues such as hotel reservations, baggage fees, food on-board, insurance and car rentals (Ryanair, 2014).

The business model of AirAsia is based on three basic low-cost airlines features: simple product, product positioning and the lowest operating costs possible. Moreover, AirAsia has many competitive advantages, such as frequent, reliable schedules; use of only secondary airports; courteous but limited passenger service; simple and lean management structure.

The above examples show three different LCCs that have the same status of low-cost carrier, but each of them used different strategy. For instance, Southwest Airlines offers a few destinations but with more daily frequencies, which is convenient for business travellers. Ryanair offers many destinations but with lower daily and weekly frequencies, which is convenient for holiday travellers. AirAsia combines both many destinations and frequencies, but its essential strategy is based on wide range of online services. Their webpage is very user-friendly, not 'intricate' as in case of Ryanair.

As any other business, low-cost airlines must expand by increasing their market share to be able to stay competitive. Based on the recent global trends, in particular in the LCC sector, we expect that the trends from USA and Asia markets will be also reflected in Europe. Low-cost carriers don't focus anymore just on the price sensitive customers (as they used at the beginning of the low-cost carriers' era) but they endeavour to strengthen their market position by higher frequency of flights. This trend is apparent in the US (JetBlue) or in Asia (AirAsia) and seems to be applicable in Europe as it has a potential to gain new passengers oriented on value offered services while preserving the product definition based on the low fares.

However, no single model will match all the requirements of the market due to fast changing air transport environment. There are not just economic or demographic factors influencing the trends of air transport development. Aircraft technology, fuel availability or fuel prices also have significant impact on airline product development from the long-term point of view. There are also other factors that were not previously associated with the pure LCC business model. It includes a use of global distribution systems (GDS) and travel agents, seat allocation, Frequent Flyer

Programmes, long-haul services or codeshare as typical features for Full Service Carriers (FSC).

Conversely, product changes can be noticed not only within the LCC segment. Market pressures forced many airlines to adopt hybrid models – where FSC operate services with some cost-cutting measures for financial viability, while LCCs start to offer some exclusive additional services in order to increase their market share and stay profitable. This results in convergence of business models– on one side FSC try to achieve lower costs, while LCCs are upgrading products and services.

PASSENGER EXPECTATIONS

In order to identify possible directions of airline product development, we ran a passenger survey, which aimed at identifying passenger needs and wants with respect to an airline product specification, features of product customers are missing or expecting, and which low-cost airline they would like to fly and why. The survey was run in 2016 using online (SurveyMonkey) questionnaire. We addressed in total 815 respondents and received 532 answers, representing 65.3 % rate of return.

From seven options of product features, the respondents marked as the highest-priority *flight safety, flight schedule and ticket prices*. These factors mostly influence customers' decision making process in their choice of low-cost airline. Any change in flight safety can have negative impact on customer. Flight safety can be also linked with aircraft fleet, therefore new aircraft, which LLCs usually use, can decrease problem of fear of flying which could be the problem of airlines which are using older aircraft types. Flight schedule can be the attribute that can differentiate airlines from competitors if timely flights will be adhered to and flight cancellations or delays will be reduced as much as possible. The price policy is important to be able to keep loyal customers and attract new potential customers due to a strong competition from LCC carriers but also from full service carriers segment.

From optional services we evaluated: guaranteed flight connections; frequent flyer programmes; wifi on board; flight entertainment; priority boarding; 2nd checked baggage; 2nd cabin baggage; name or flight change; seat reservation and free food. From among these options (it was possible to check more alternatives), a 2nd checked baggage was selected as the most preferred service by 72% of customers. The second preferred option was guaranteed flight connections, with the 56 % of the customers. However, this could hardly be included as an optional service by most of LCC airlines as it requires creation of hub and spoke system which results in considerable cost increase.

According to customer satisfaction (rated from 1 to 4) we evaluated ten LCC airlines and sorted them in three groups: *economy* (with mean value of customer satisfaction less than two), *premium* (the mean value from two to three) and *fancy* (the mean value higher than three) (see Figure 1).

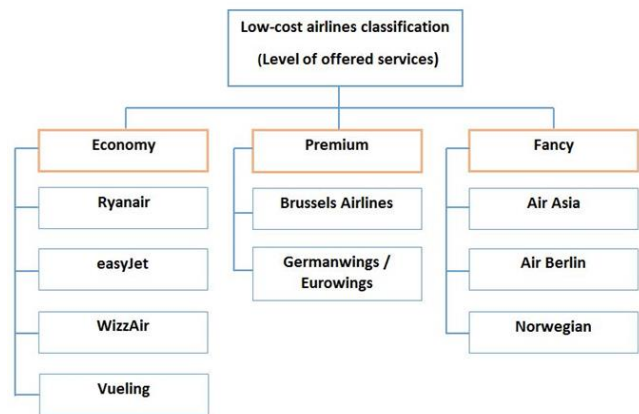

Figure 1 Low-cost airlines classification according to level of offered services (Source: Mrázová, M. 2016)

SCENARIO WRITING - LOW-COST CARRIERS FUTURE SPECIFICATIONS

Based on the survey results as to passenger expectations, , analysis of case studies related to the low-cost airline business models and expert elucidation, possible scenarios of future LCC trends were drawn up.

The findings confirmed that all low-cost contemporary models are mostly based on the Southwest Airlines business model concept. Southwest offered just *essential product* (transportation from destination A to destination B on short-medium haul flights) and oriented just on so-called *price conscious customers*.

Lately, airlines started to adopt new strategies in order to improve airline product. Even the ‘pure’ LCCs were forced to modify their product. For instance, Ryanair introduced *business plus* travel class in August 2014. It was presented as a response to customers desire based on a flexibility and a better schedule that ensures flights to the required business destinations – e.g. Madrid or Barcelona (three or four times daily returns). Ryanair also started campaign ‘always getting better’, made changes in the quality and design of cabin crew uniforms, and tries to improve staff behaviour towards customers. However, evaluating Ryanair against best practices indicates that there is still much to be done. While part of their cultural lag is digital, it also reflects the historic lack of competitive pressures (from other low cost carriers) on many of their routes.

The orientation on only price sensitive customers was linked with the orientation on quality-conscious customers, too. Saturation of the market limited the conditions for further expansion therefore future low-cost airline product improvements could be expected in terms of quality of passenger services and product personalisation, which will also increase income from ancillary services (see Figure 2).

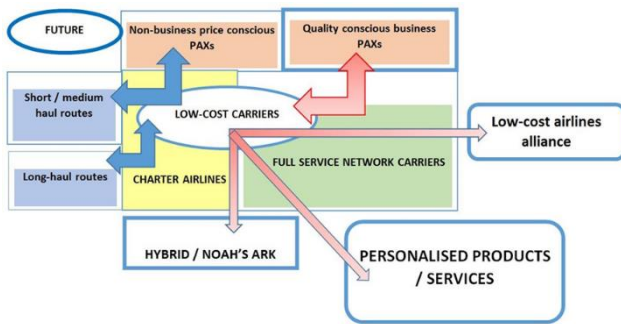

Figure 2 Future low-cost airline product development

[Source: Mrázová, M. 2016]

CONCLUSION

Since the beginning of the deregulation process when the first low-cost carriers appeared, airline products have changed considerably. While the start of deregulation caused a real revolution in air transportation, subsequent transformation of 'pure' low cost business models are an evolution¹¹. Expanding of the LCCs in the price sensitive sector of passengers caused that the carriers hit limits for growth and they have to explore other business opportunities to overcome market saturation. One of possible strategies is a product 'hybridisation', to cover as much of a market share as possible. The first representative of this market strategy is Singapore Airlines that was successfully followed by AirBerlin and other carriers, including legacy Lufthansa. The low-cost airline product is moving towards product personalisation where the customer will precisely define what kind of services they expect and desire. Additional services that represent customers' needs and wants will be important in the offer of low-cost carrier business model. Due to strong positions of LCCs the full service carriers can lose their share of market in Western and Central Europe. At the same time, network carriers might have to withdraw or downsize their operations on some routes. Therefore, stronger low-cost carriers will probably fill additional gaps in route networks that were before served by full service carriers.

REFERENCES

- [1] Bamber, G.J., Gittell, J.H., Kochan, T.A. & von Nordenflytch, A. (2009). "Up in the Air: How Airlines Can Improve Performance by Engaging their Employees". Cornell University Press, Ithaca,
- [2] Button, K. (2009). The impact of US-EU Open Skies agreement on airline market structures and airline networks. *Journal of Air Transport Management*, 15.

- [3] Calder, S. (2002). *No Frills - The Truth behind the Low-cost Revolution in the Skies*. London: Virgin Books L.
- [4] Gillen, Morrison. (2003). Bundling, integration and the delivered price of air travel: are low cost carriers full service competitors? *Journal of Air Transport Management* 9 (1), pp. 15-23.
- [5] Gittell J. (2003). *The Southwest airlines way*. McGraw Hill
- [6] Kavková, A.: *Úvod do štúdia sociológie podniku*, Bratislava: Alfa, 1978
- [7] Mrázová, M.: *Low-cost Carriers Operational and Economic Model Development*, University of Žilina, 2016
- [8] Ryanair. (2014, April). Full year results 2013. Retrieved July 2014, from https://www.ryanair.com/doc/investor/present/quarter4_2013.pdf
- [9] Taneja, N. (2014). *Designing future oriented airlines businesses*. Ashgate Publishing Company.
- [10] *Airport Typology Impact of low cost carriers operations*, Ing. Marek Turiak 2015;

ACKNOWLEDGEMENT

This paper has been created following the project in the process of solution which has been co-financed by the EU sources entitled „ Centre of Excellence for Air Transport Centrum- ITMS 26220120065.“



AUTHOR INFORMATION

Antonín Kazda, Professor, Air Transport Department, University of Žilina, Slovakia

¹¹ A process of slow change and development. (<http://www.merriam-webster.com/dictionary/evolution>; retrieved 9.10.2016)

IS IT JUST CULTURE MEASURABLE? – CAN WE MODEL THE JUST CULTURE CONCEPT?

Mária Kováčová

LPS SR, š.p., Slovakia

maria.kovacova@lps.sk

Ján Bálint

Flight Preparation Department, Faculty of Aeronautics, Technical University of Kosice, Slovakia

Jan.balint@tuke.sk

Antonio Licu

EUROCONTROL

antonio.licu@eurocontrol.int

Ivana Kazimírová

Virgin Australia

ikazimirova@yahoo.com

Abstract – Just Culture (JC) has now widely been recognized and accepted as an essential condition for protecting and promoting the reporting of safety occurrences by aviation professionals without undue fear for criminal or corporate sanctions. Determining an optimal implementation of JC is therefore a basic requirement for its modelling and effectiveness in the ATM domain. Early efforts in EUROCONTROL to measure JC performance as required under EU law have now become obsolete in view of the advancing insight in developing indicators and markers for the measurement of JC in Air navigation Service Providers. This article identifies the need to explore and measure the emergence of new concepts such as JC and its interaction with the classical safety regulatory environment. It describes and discusses the recent initiatives of the EUROCONTROL Just Culture Task Force towards reviewing the performance review model. It analyses and proposes the use of smart technologies for improvement and for adaption and better calibration of more accurate measurement, together with the identification the enablers and issues around an organization to facilitate the Just Culture implementation. Finally, it will address questions related to identifying the key elements for effective measurement of JC and how to address the reactions by the various actors in responding to JC measurement soft and hard law

Key words – effectiveness, just culture, modelling, measurement, occurrence, performance, reporting system, safety, severity.

INTRODUCTION

The concept of “just culture” has become better understood and accepted by aviation personnel. The removal of real or perceived obstacles against the establishment of a “just culture” in aviation (or other transport modes such as railway or maritime) does not necessarily require the creation of additional legislation at international/regional level, but should concentrate firstly on appropriate clarification and implementation initiatives at national and corporate level.

A “just culture” in aviation has been described initially by EUROCONTROL SAFREP TF as a culture in which front line operators or others are not punished for actions, omissions or decisions taken by them that are commensurate with their experience and training, but where gross negligence, wilful violations and destructive acts are not

tolerated. Subsequently this description has been captured by EU and has been formally enacted in European legislation namely in EU Regulations 691/2010, 390/2013 and 376/2014.

A schematic representation where to delineate “just culture” is represented in the figure 1.

Just Culture signifies the growing recognition of the need to establish communication and training initiatives and advance arrangements between the aviation safety sector, regulators, law enforcement and the judiciary to avoid unnecessary interference and to build mutual trust and understanding in the relevance of their respective activities and responsibilities.

Here is a less diplomatic version: Just Culture is about creating a workable balance between Safety and Sanctions through an important message: Stay away from professionals that make an honest mistake, but someone who consciously takes an irresponsible risk should be sanctioned. It is that simple – it is that complicated.

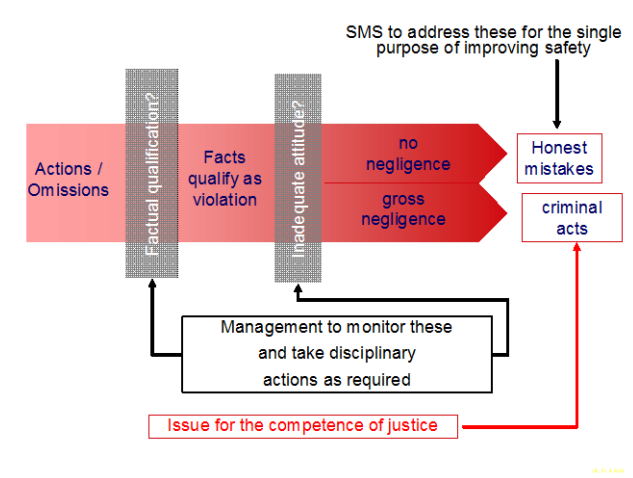

Figure 1 – Just Culture concept

ENGINEERING A JUST CULTURE

The basic engineering principles related to reporting culture in the light of JC principles can be borrowed from different areas such as medicine, oil and gas industry, nuclear industry, etc. Research of some successful methods and schemes indicates that 5 factors are important in good quality and proper quantity of incident reports. These factors are important for creation of climate of trust and for positive motivation of employees:

- Protection against disciplinary proceedings (as far as it is practicable and legally acceptable);
- Dis-identification;
- Independence of investigation team from internal bodies with authority to institute disciplinary proceedings;
- Accessible and user friendly reporting system;
- Ease of making report.

Best practice to establish JC can be described briefly in these steps:

1. Define the legal aspects
2. Define policy and procedures
3. Establish easy and clear methods for reporting
4. Set-up roles and responsibilities
5. Develop required forms and templates
6. Provide fast feedback to reporter
7. Create an educational plan

The first steps towards alleviating or changing the legal constraints could be for individual states:

- To clearly identify the issues at stake and the circle of national authorities to be involved, in their specific environment;
- To define a process for the establishment of the dialogue required between all national parties involved;
- To conduct a legal analysis of the issues arising from the implementation of JC in ANSP, from which a clear vision and action plan will emerge.

In order to reconcile with the judicial system, the two most important issues are – indemnity against disciplinary proceedings and establishing a corporate JC policy that supports reporting and investigation of incidents.

THE 2010 – 2019 MODEL

The E.U. Commission Regulation Nr. 691/2010 of 29 July 2010 lays down a performance scheme for air navigation services and network functions and amends Regulation (EC) No 2096/2005 laying down common requirements for the provision of air navigation services.

The establishment of the above-mentioned scheme derive from what is stated in the Regulation (EC) No 549/2004 of the European Parliament and of the Council of 10 March 2004 laying down the framework for the creation

of the Single European Sky, the so called “Framework Regulation”. It requires the setting up of a performance scheme for air navigation services and network functions by means of implementing rules.

The aim of the performance scheme is to provide a contribution to the sustainable development of the air transport system by improvement of overall efficiency of the air navigation services across the key performance areas of safety, environment, capacity and cost-efficiency, in consistency with those identified in the Performance Framework of the ATM Master Plan, all having regard to the overriding safety objectives.

The questionnaire was designed to provide an overall measure of the level of Just Culture implementation by the use of a yes/no response in a number of areas considered as essential for the Just Culture.

These areas are:

- Policy and its implementation.

This area has three sub-areas, as follows:

- o Policy elements;
- o Roles and responsibilities;
- o Training.
- Legislation;
- Occurrence reporting and investigation.

Each of these five areas has been identified as important for the development and maintenance of a Just Culture within an organisation. The policy area refers to a formal policy that an ANSP should have in place, which must be endorsed by top management as well as staff, cover a number of basic elements (such as a declaration of non-punishment in cases of self-reporting) and have a number of practical elements in place. Among these elements a clear definition and repartition of roles and responsibilities with regards to safety (in particular occurrence investigation), as well as appropriate training were identified as particularly important areas.

It must be understood that this does not evaluate in any way the internal performance of the ANSP but merely the strength of its Just Culture. If the said Just Culture is subject to external elements and negative pressures, an ANSP is all but unable to develop and properly maintain a fully functioning Just Culture. There are many such examples where the ANSP has done all in its powers to implement a Just Culture, yet the general environment in the State is not

supportive, therefore the ANSP is compelled to accept that its Just Culture may have significant limitations and has to accept the consequences. Last but not least, the area of occurrence reporting and investigation sits at the core of the Just Culture and it is also the part that would immediately benefit from a proper Just Culture within any organisation. However, its implementation also needs to follow certain rules and support the Just Culture.

All these elements have been considered and a number of questions relevant for the subject and for an ANSP were created. The answers are simple yes/no, whereby a “yes” answer would indicate the presence of that element in favour of the Just Culture.

ENHANCEMENT OF THE MODEL 2010-2019

At the beginning of 2010 was officially introduced model for measuring Just Culture development within the organisation itself and within the state too. This model was based on the experience of professionals involved in the JC task force. At that time no regulation was in place and not all organisations were compliant with main Just Culture principles.

Some of the European states and ANSPs had officially stated Just Culture policy but most of them were missing official internal process and of course clear correlation with criminal law within the country.

The first model of questionnaire consists of 24 questions which are mostly focused on the implementation stage of Just Culture principles. At that time was very important and necessary step to be taken by ANSPs and states. It was obvious that such questionnaire brought more questions on table not just how to implement JC principles but how to perform internal processes or processes on state level in line with these JC principles.

This questionnaire was very important step to bring attention of the ANSP management and employees but also the attention of aviation authorities as well as representatives of legal system of states to Just Culture topic. By history were common cases when JC principles were abused or evaded and by the outputs of this questionnaire were known case when punishment for involved personnel into incident was too strong or too weak.

This topic was after certain time finally taken into consideration of European Commission with the major intervention of EUROCONTROL and representatives of IFATCA. EC gave mandate to EASA to run survey and study regarding this topic and bring efficient solution. EASA

based on the knowledge and experience of aviation stakeholders majority proposed new regulation containing JC principles and new accident and incident reporting regulation.

At that time one of the most important deliverables of EUROCONTROL and Just Culture Task Force was the development of a model for a JC based national aviation prosecution policy which could be modified based on the specific need of the prosecutorial authorities. EUROCONTROL also provides support during implementation stage with its professional knowledge and experience and by sharing best practice across members States.

With the collective experience of 5 years of gaining information and know-how it was decided to move forward in Just Culture topic by the way of spreading knowledge through aviation stakeholders and through the national judiciary.

In Europe, the EU has not only formally enacted Just Culture as part of EU law, but it has also recently introduced in 2010 a new Regulation governing air accident and incident investigation that also addresses the need to achieve a balance between the objectives of the judiciary to determine whether criminality was involved, and the need for the aviation industry to be able to run a real-time self-diagnostic system without unnecessary interference from Justice.

The Regulation states that its purpose is dual: to regulate both "the investigation and prevention of accidents and incidents". It says: "An accident raises a number of different public interests such as the prevention of future accidents and the proper administration of justice. Those interests go beyond the individual interests of the parties involved and beyond the specific event. The right balance among all interests is necessary to guarantee the overall public interest."

Just Culture represents the fundamental recognition that both the aviation safety drive and the administration of justice will profit from a carefully established equilibrium, moving away from criminalisation fears. It is based on the understanding that controllers and pilots can blunder and that the line between an "honest mistake" and intentional or reckless behaviour can only be drawn by a judiciary professional.

That is easier said than done, of course. But the time has come to seriously query the added value of endless and generally unsuccessful efforts at International level to "protect" controllers and pilots against judiciary actions by

creating standards, regulations and laws that are supposed to shield them against interference by justice.

In the light of these findings, the team responsible for evolution of JC questionnaire decided to rebuild and modify existing model based on these priorities:

- do not to require by internal process fixed line on "acceptable" professional behaviour within organization;
- prescriptive questions will be used just in areas which are requested by regulation;
- by questions to focus on two areas of Just Culture – internal and external;
- introduction into questions workforce perception.

The new form of questionnaire is organized on three major domains (External, Corporate and Workforce) in order to provide a better understanding of the global results from all assessments.

The first domain, the "External domain" has three subcomponents which are presented as levels. The "Legislation level" is the first one, containing statements with respect to data protection legislative action and support. The "Judiciary level" is the second, presenting several ideas regarding the judiciary involvement towards the concept of Just Culture. The third level is the "Public/Media" including statements with reference to the interest towards Just Culture and their actions for and/or against it.

The "Corporate domain" is constructed on three levels, "Policy", "Procedures" and "Promotion". "Policy" includes various areas of analysis towards the implementation, support and endorsement towards a Just Culture Policy. The "Procedures" level is structured on sublevels in which information regarding safety data and reporter protection is assessed. Last but not least, the "Promotion" level displays main ideas formulated upon promoting best practice, data availability and awareness.

The "Workforce domain" has only one level of evaluation ("Perception") which is based on numerous assessments. This particular domain is related to the commitment, interest, awareness and understanding of the workforce with respect to policies, procedures and principles of Just Culture.

The JC Strawman is based on an algorithm that allows respondents to assess and score how well Just Culture in their organization. These final scores create an overview about the importance and implementation levels of each judgement in the context of supporting Just Culture in order

to better analyse and assess current developments and further improvements.

By verification of all above mentioned domains it can be ensured that Just Culture is not just officially implemented and stated but also performed by management and stated authorities and believed by every employee.

This new questionnaire is nowadays in simultaneous usage by certain ANSP for verification of the questions and if they are understandable and possible to prove for stated weight.

OTHER WAYS OF DEALING WITH JUST CULTURE

While a lot of progress has been made to understand and shape a position on Just Culture in the aviation field, the generally identified need to effectively bridge the gap towards the judicial world remains a challenge. Whereas all applicable legislation acknowledges the need to learn from serious incidents and accidents and that this can be best achieved by having a Just Culture approach with regard to reporting, the same legal provisions clearly recognise that there cannot be any prejudice against that the administration of justice of a state as a sovereign function that has to be fully respected

In aviation, certain initiatives are under way to establish a comprehensive repository for all relevant legislation, corporate and judiciary commitments or policies and guidance material relevant to an open safety culture. A fully accessible electronic JC Repository and Knowledge Centre would have the form of a living document with clear ownership, professionally and independently managed through e-media and with fully updated listings of applicable law and regulations as well as established policies and commitments that are signed off. It should also provide amendment, extension and implementation of JC related initiatives and commitments.

CONCLUSION

At the end it is crucial to ask the question how important is to properly measure just culture. Is it really so necessary to perform it in proper way? The answer is yes and no in the same time. Measurement of JC is feedback for states and management of organization needed to plan proper measures for improvement of JC.

Based on many research studies of diversity of cultures over the world, Europe, state and organization is well known the fact that for efficient change of culture you need change of generation. As very important indicator and cursor can be

the results from JC measurement. It is the effective way how to plan next steps by management and by States themselves. It can be also proof that within the area of your responsibilities you have achieved maximum level and the only way to success is just keep the way which was chosen at the beginning.

Main idea of positive Just Culture creation is to emphasize the importance for first line operators and managers to report occurrences in a supportive environment. Based on well-analyzed data streams we can improve our systems within aviation and ensure high level of safety and reduce the potential risk of accidents.

REFERENCES

- [1] REGULATION (EU) No 376/2014 OF THE EUROPEAN PARLIAMENT AND OF THE COUNCIL of 3 April 2014 on the reporting, analysis and follow-up of occurrences in civil aviation, amending Regulation (EU) No 996/2010 of the European Parliament and of the Council and repealing Directive 2003/42/EC of the European Parliament and of the Council and Commission Regulations (EC) No 1321/2007 and (EC) No 1330/2007
- [2] E.U. Commission Regulation Nr. 691/2010 of 29 July 2010 lays down a performance scheme for air navigation services and network functions and amends Regulation (EC) No 2096/2005
- [3] COMMISSION IMPLEMENTING REGULATION (EU) No 390/2013 laying down a performance scheme for air navigation services and network functions
- [4] EUROCONTROL (2014) – HINDSIGHT Magazine Issue 18 – Safety and Justice.
- [5] AMER M. YOUNOSSI, CHARLES HUBER: A common approach to safety performance measurement, Safety Management International Collaboration Group, 20 April 2010, pp. 1-3.
- [6] TONY LICU, EVE GRACE KELLY: 3rd SAFREP TF Report to Provisional Council European ATM Safety Performance Indicators, ATM Safety Framework Maturity Survey Methodology for ANSPs, Released - Edition 1, pp. 7-18.
- [7] A.L.C.ROELEN, M.B.KLOMPSTRA: The challenges in defining in aviation safety performance indicators, Preprint for PSAM 11 and ESREL 2012, 25-29 June 2012, Helsinki, pp. 1, 6.
- [8] ICAO: International standards and practices, ANNEX 19 to the Convention on International Civil Aviation, Safety Management, First edition, July 2013
- [9] TONY LICU, RADU CIOPONEA – Just Culture Survey of European ANSPs, 2011

- [10] SIDNEY DEKKER: Just Culture, Balancing Safety and Accountability, Second edition, Ashgate 2012
- [11] TONY LICU, EVE GRACE-KELLY: ATM Safety Framework Maturity Survey Methodology for ANSPs, 31 August 2009, pp. 7-13.
- [12] EASA: Executive Director Decision 2014/035/R of 16 December 2014 adopting Acceptable Means of Compliance and Guidance Material for point 1 of Section 2 of Annex I to Regulation (EU) No 390/2013 and repealing Decision 2011/017/R of the Executive Director of the Agency of 16 December 2011, AMC and GM for the implementation and measurement of safety (Key) Performance Indicators (S(K)PIs) — Issue 2
- [13] http://prudata.webfactional.com/wiki/index.php/Reporting_of_Just_Culture

[14] <https://www.eurocontrol.int/articles/just-culture>

AUTHOR INFORMATION

Ján Bálint, Professor, Flight Preparation Department, Faculty of Aeronautics, Technical University of Kosice, Slovakia.

Tony Licu, Head of Safety Department, NM Division, EUROCONTROL

Mária Kováčová, Head of Safety Department, Letové Prevádzkové Služby Slovenskej republiky, š. p.

Ivana Kazimírová, captain ATR-72, Virgin Australia

SELECTED ASPECTS OF APPLYING MODERN TECHNOLOGIES IN AVIATION TRAINING, EXEMPLIFIED BY POLISH AIR FORCE ACADEMY IN DĘBLIN

Assoc. Prof. Eng. Jarosław Kozuba, PhD

Polish Air Force Academy, Dęblin, Poland

jkozuba@wsosp.pl

Abstract - The application of more and more modern technology in contemporary aircraft and the related, frequently new, threats to aviation safety cause the training tools used in this process to be constantly enriched, and those already existing to be subject to constant upgrades. This article makes a reference to the application of modern aviation training tools in the process of training officer cadets – pilots, navigators, and technicians – at the Polish Air Force Academy (PAFA) in Dęblin. Various types of training devices have been characterized from the perspective of their application in the air training process. At the conclusion, reference was made to the modern training environment, exemplified by that dedicated to the training administered to M-346 aircraft pilot candidates.

Key words - Aviation training, aviation simulator, technologies, aviation personnel, PAFA.

INTRODUCTION

The results of the analyses conducted by the author of the article clearly point out to the fact that irrespective of the type of aviation, the aircraft, and its nationality, or the time period taken into consideration, it is the human being – the pilot, mechanic, air traffic controller – that is the underlying factor of almost 70% of undesirable flight-related events (Kozuba, 2013). Z. Błuszczynski, when considering the relationship between the human factor and the undesirable flight-related events (Błuszczynski, 1976), highlights the inadequacy of the actions taken by operators – pilots and other aviation personnel who closely connected with flights, their organization and safety – to the situation that occurred in a certain phase of flight. Such an inadequate action usually leads to an undesirable flight-related event. That situation occurs when threats caused by factors independent from human control have not been removed, or reduced to an acceptable level, despite the real possibilities of doing so. Every action is a result of a particular decision and the

related decision-making process. The factor which conditions the emergence of an undesirable flight-related event is usually the occurrence of several consecutive errors in the system of directing (management) an aviation organization, errors in handling the aircraft or in air traffic control, and / or operational errors committed by the air crew. The causes of erroneous decisions made by the pilot-operator are sought for at various stages of investigation whose aim is to discover them, taking into account particular complexity of the aviation system and its environment. Therefore, when discussing the causes of undesirable flight-related events, errors committed by the crew of the aircraft at various stages of the decision-making and implementation process are generally regarded as the key factor resulting in more or less serious consequences. Consequently, in the era when aviation technology is subject to dynamic development, great importance is attached to the quality of flight training, regardless of whether it is basic flight training or professional development training. Modern methods and tools used in the training process are expected to allow for the preparation of highly qualified aviation personnel having a high level of expertise and a broad range of skills which guarantee achieving the desired level of air mission execution at an acceptable level, from the perspective of aviation safety.

Speaking of flight training, we mean three cyclically repeated stages of that training (Fig. 1), the intensity of whose occurrence is dependent on, among other things, such factors as the training level of the pilot, the complexity of the air missions to be performed, the level of aircraft automation, etc.

In this article, the author relied on the training practice implemented at the Polish Air Force Academy (PAFA) and on the theory and research described in reference literature. The Polish Air Force Academy is a military-civilian

institution of tertiary education which prepares personnel for the needs of the Air Force units of the Polish Armed Forces, and for civil aviation.



Figure 1 Air training process
(Source: Author's own work)

Aviation training for pilots, technicians, and air traffic controllers is conducted within the framework of the 1st degree (BSc) and 2nd degree (MSc) study courses. The Academy also provides training for other personnel responsible for the accomplishment of air missions. Since 2014 the pilots have been trained according to a new flight training syllabus (Fig. 2), which allows them to achieve the flying time of 215-260 hours, depending on the particular pilot's specialization. Their training consists of two basic components, i.e. the training for ICAO rating endorsements using general aviation airplanes / helicopters, and the subsequent advanced air training, for which they are sent to the 4th Air Training Wing, where military trainer airplanes and helicopters are used.

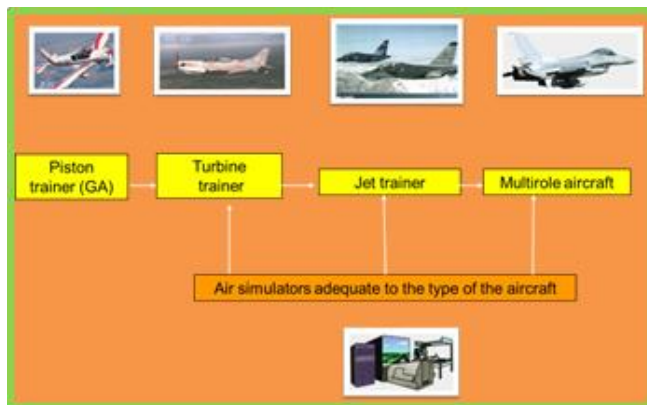

Figure 2 Algorithm for training jet pilots at the Polish Air Force Academy. Source: Author's own work
(Source: Author's own work)

MODERN TECHNOLOGIES IN ACADEMIC INSTRUCTION FOR AIR PERSONNEL

A crucial element in the preparation of the syllabus and the schedule of flight training is a skilful combination of theory

and practice, taking into account the relevant training methods and techniques. In the reference literature relating to technical training, and air training should be regarded as such, the ratio between lectures and labs / exercises / workshops should be 50% to 50%, indicating an increase of the latter to 60%. Confirmation of this view is also found in the conclusions of the so-called Dale theory (Fig. 3). According to this theory, the least effective lecture is a passive transmission of contents (listener – verbal presentation) – the trainee retains 10–20% of its contents. Therefore, each lecture / class should be enriched with multimedia presentation and practical activities – exercises, laboratories. The instructor / lecturer should strive to engage the trainee in a discussion with the aim of solving a given problem, which in turn should result in increased content retention to approximately 50%. On the other hand, allowing the listener to prepare to give a lecture, presentation, and to participate in the discussion during the class or laboratory exercises increases the content retention to approximately 90%. It should be emphasized that in the case of e-learning, lecture should be seen as a preparation for working "on the line", in close cooperation with the lecturer / instructor.

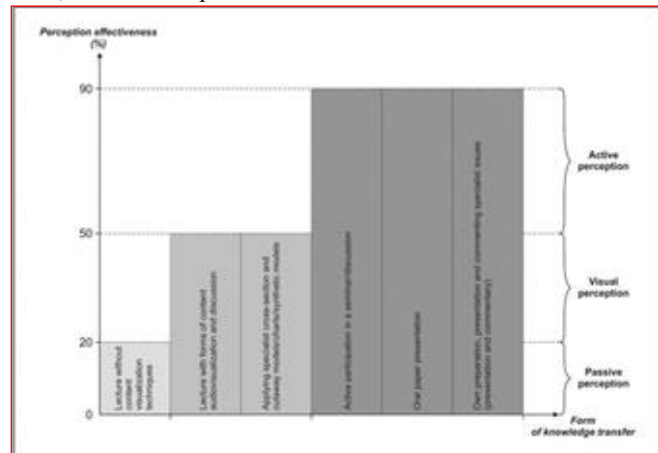

Figure 3 Influence of the method (technique) of conducting the classes on the training effectiveness
(Source: Author's own work. (Kozuba, 2013))

Modern tools of academic instruction, approved by ICAO for use in the air training process can be divided into four basic types:

- *Web Based Training* (WBT) – instruction delivered with the use of websites;
 - *Computer Based Training* (CBT) – instruction delivered with the use of a computer (Fig. 4);
 - *Blended Learning* (BL) - teaching, which combines the elements of a traditional course (lectures, classes) and the elements of distance learning;
 - *E-learning* – instruction delivered with the use of electronic media (computer, Internet, audiovisual equipment, etc.).
- Current aviation regulations allow the use of all of the above-mentioned training forms, but more attention should be paid to the last of them, e-learning. It should be stressed that lectures carried out in the traditional form can be seen as preparation for instruction delivered in the e-learning form. The reference literature presents a belief, which is reasonable

according to the author, "that the technology [e-



Figure 4 Modular Simulated Aircraft Maintenance Trainer (CBT) at PAFA. (Source: PAFA)

learning – author's note] alone is not a miraculous means to overcome the difficulties faced by the training systems. This technology should be used in conjunction with conventional forms of education [lectures, classes, labs, etc. – author's note], and not be treated as an alternative method which is autonomous in relation to other methods" (Delors, 1998). The fundamental problem with which we are dealing in the process of transforming a modular training program, for instance, e-learning program is a remote possibility, or lack thereof, of meeting the training objectives connected with the acquisition of practical skills by the trainees. We are speaking here of basic practical skills which are usually mastered by the trainee during the classes and labs carried out in the theoretical phase of the training. Therefore, in the opinion of the author, the flight training conducted in the form of e-learning should be complemented by using previously existing training forms, where the trainee can be in contact with a specific training device, flight simulator, a part of aircraft equipment, or the aircraft itself, with which he interacts when training practical skills. With so understood a form of flight training, the trainee is also likely to be supported by the instructor, and the emerging concerns can be addressed almost immediately during the lesson. With

respect to elements of pilot professional development, e-learning can be applied in a much wider range. E-learning may be treated as a separate form of expansion and consolidation of the pilots' knowledge, and an essential tool for verifying their theoretical knowledge, as specified by the relevant regulations and the aviation organization.

In conclusion, just as simulators cannot completely replace practical training on the aircraft, e-learning should not be a substitute for classroom instruction. Organizations selecting this method of training should review the level of skills of individual instructors they employ, taking into consideration the requirements of e-learning. The effects of training will always depend on the skills of instructors, which in all likelihood can be evaluated on the basis of the level of knowledge and skills demonstrated by the trainees after the course completion.

MODERN TECHNOLOGIES – TOOLS AND DEVICES ASSISTING FLIGHT TRAINING

Flying is a difficult, complex task requiring from pilots vast general knowledge base and technical expertise as well as a wide range of skills appropriate to the aircraft type and the tasks performed. The result is that particular attention is currently paid to the development of air training equipment, which is used in the process of basic training and professional development of pilots.

Air training devices, in addition to school/trainer aircraft, are practical and proven tool to assist the process of theoretical and practical pilot training (Fig. 5).

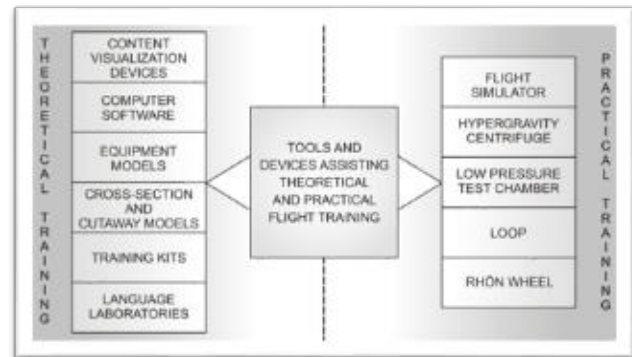

Figure 5 Tools and devices assisting flight training (Source: Author's own work)

Specialized training using air training devices is commonly administered to PAFA students. This form of training supports the process of flight training, and it is also a fundamental method of exerting a holistic impact on a pilot's organism, which comprehensively develops the desirable psychophysical traits in a trainee.

1. *Loop*¹², *single Rhön Wheel*¹³, and *Gyroscope*¹⁴ are qualified as Gymnastic Training Equipment for Pilots

¹² Loop is a kind of swing supporting full pendular movements, forwards and backwards, and, after unlocking, simultaneously left-right rotations around the longitudinal axis of the trainee's body [Stełęowski, Kłossowski, Wochoński, 2011].

¹³ Gyroscope is a kind of double Rhön wheel which, owing to its gyroscopic suspension, supports axial rotations around all axes passing through the

center of the trainee's body, simultaneously in all planes [Stełęowski, Kłossowski, Wochoński, 2011].

¹⁴ Rhön wheel supports alternating rotations around two different axes passing through the center of the trainee's body. When the trainee is tied in facing forwards, the rotation takes place around the sagittal axis in the frontal plane in both directions. When the trainee is tied in facing sideways,

(GTEP), which is used in pre-flightfitness-conditioning training for military pilots.

They affect the improvement of the pilots' psychomotor proficiency, especially their eye-hand coordination, spatial orientation, and balance, in all flight states. The research studies conducted by A. Stelęgowski, M. Kłossowski, and Z. Wochoński which concerned a group of PAFA cadets clearly indicate that the exercises using the GTEP mentioned above bring about beneficial, statistically significant, changes in such areas which are important for the pilot as: coordination, spatial orientation, strength and the speed of reaction to changes in the mission environment (Stelęgowski, Kłossowski, Wochoński, 2011) (Fig. 6).

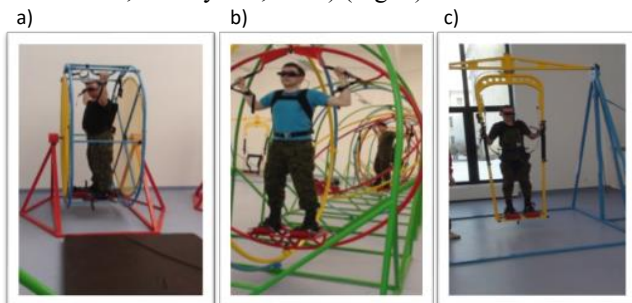

Figure 6 Training enhancing the resistance against motion sickness and developing the efficiency of eye-hand coordination, a) single Rhön wheel, b) gyroscope, c) loop – PAFA training equipment (Source: PAFA)

2. *Hypergravity centrifuge* is the device used for creating hypergravity. It is commonly used in aviation and aeronautics in order to examine the impact of hypergravity on the human organism. It consists of a long arm at the end of which there is an aircraft cockpit. During rotary motion the cockpit is subjected to strong centrifugal force (largely exceeding the weight) which creates hypergravity. Centrifuges can create forces of several dozen "g", exceeding the capabilities of the human body several times.

3. *Hypobaric chamber* is a device for testing and training aircrews under reduced barometric pressure in complex altitude combinations. The chamber is designed to perform the following tests: periodic – in order to determine the degree of the body resistance to the effects of oxygen deficiency and the influence of altitude; occasional – in order to determine the resistance of the immune system to oxygen deficiency or to regain such resistance; special – according to the desired profile [13].

4. *Flight simulator* is a technical device or a computer program which imitates the aircraft operation under real flight conditions. Simulators can be take the form from simple computer games to advanced flight simulators which are full-size, functional duplicates of the cockpit along with the on-board systems and instrumentation mounted on a hydraulic platform or hypergravity centrifuge, which produces hypergravity values equal to those occurring in various phases of the aircraft flight.

the rotation takes place around the sagittal axis forwards and backwards [Stelęgowski, Kłossowski, Wochoński, 2011].

Taking into consideration design complexity and the applied degree of fidelity in imitating cockpit instruments, equipment, and systems of the aircraft, as well as the manner of simulating the loads occurring during the aircraft manoeuvres, flight simulators (Flight Simulation Training Devices – FSTD) can be divided into four main groups:

1. *Full Flight Simulator (FFS)* (Fig. 7a) - the most technologically advanced simulator type. Complete, full-sized and functional cockpit replica of a certain aircraft type, model or series, combined with the appropriate computer system necessary to imitate the aircraft during ground and air operations. The system of visualization provides a view outside the cockpit, and the system of actuators imitates the physical sensations associated with motion. Devices of this type are used, among others, in training flight crews in dangerous flight conditions, acquiring the appropriate habits, and in maintaining currency.

a)



b)



Figure 7 Full Flight Simulator (Disorientation Simulator, a) and Flight Training Device (FTD - b) at PAFA (Source: PAFA)

2. *Flight Training Device (FTD)* (Fig. 7) – complete, full-sized and functional cockpit replica of instruments, equipment, and control panels of a given aircraft type, combined with the appropriate computer system necessary to replicate the aircraft during ground and air operations. These devices do not have to be equipped with visualization and motion imitation systems.

3. *Flight and Navigation Procedures Trainer (FNPT)* (Fig. 8a). In this type of simulators the cockpit is connected with a suitable computer system necessary to represent a particular type, or group of types, of aircraft during in-

flight operations. Devices of this type are used i.a. in training IFR flights and in navigation training.

a)



b)



Figure 8 Flight and Navigation Procedures Trainer (FNTP-II - a) and Basic Training Device (BTD- b) (Source: PAFA)

4. *Basic Instrument Training Device (BITD)* (Fig. 8b) – a device imitating the instruments of an aircraft (possibly displaying them on the screen) to be used in practicing at least the procedural aspects of an IFR flight.

Simulators approved for the training of licensed aviation personnel have to meet the requirements described in civil aviation regulations. Military simulators must meet the requirements specified by the contracting party. These requirements are largely consistent with those applicable in civil aviation. In these requirements great emphasis is put on the fidelity of the cockpit instrument replication, including certain versions of the aircraft, allowing to train the full spectrum of missions executed by a given aircraft.

The effectiveness of practical training using flight simulators is determined by a number of factors, including, among others, such as safety, economic, technical, methodological, etc.. Due to the fact that the desired level of simulator training effectiveness has to be accomplished, and to the versatility of flight simulator use, these devices must fulfill a number of functions. The essential functions of a simulator used for training and professional development of pilots may include:

1. *Demonstration function* – it is associated with the enrichment of the academic instruction process with practical elements, allowing to demonstrate the trainee

specific procedures, methods, and uses of equipment, instruments and onboard systems.

2. *Education function* – it is associated with such aspects as forming / mastering the trainee's skills and habits related to practical execution of tasks in the cockpit, the use of operating procedures, procedures to be followed in the event of an onboard emergency, improvement of multi-crew cooperation, improvement of skills regarding the use of phraseology, improving the skills of flight training instructors, etc.

3. *Personality function* – it is associated with the forming and development of desirable personal-professional traits of the pilot (trainee), preparing him, among other things, to execute air missions under high workload and / or in time deficit conditions, including the emergence of situations on board, or in the mission environment, which are new from the perspective of the pilot's (trainee's) current experience, etc.

4. *Adaptation function* – it amounts to it the improvement of the pilot's (trainee's) ability to perform "repetitive" tasks on board the aircraft, including those related to activities performed in complex and emergency situations. Exercises performed within the scope of this function are particularly important in preparing pilots for the execution of an air mission which is new from the perspective of their previous professional experience.

5. *Research function* – it is connected with checking the pilot's (trainee's) behaviour at various stages of the planned mission execution taking into account the specific structural and ergonomic, or automation solutions related to a particular aircraft type. It also amounts to checking the validity of theoretical assumptions related to the way of solving the problem onboard the aircraft by its crew, e.g. the validity of the assumptions about the way the crew should act in the event of a specific emergency situation onboard the aircraft. This function is also used whenever it is necessary to confirm the conclusions reached by air accident investigation boards, relating to the causes of an undesirable flight-related event.

6. *Screening function* – it consists in eliminating, permanently or temporarily, from further flight training persons who do not have predispositions (competences, knowledge, skills) to be pilots / perform specific aviation tasks.

7. *Control-examination function* – owing to which it is possible to carry out control / examination exercises in related to specific tasks and aviation ratings (Pielacha, 2000).

It should also be stressed that the effectiveness of the use of flight simulators in the recruitment and selection process, basic and advanced training of pilots, air accident investigations, or studies is conditioned by understanding their capabilities and limitations which apply to specific areas of activity in aviation. On the other hand, while creating them, apart from the use of certain modern aviation technologies, a very important element is the desire of the constructor to create such a mission environment for the pilot, which would be as close to the reality as possible, to take into account the knowledge of human capabilities and

limitations, including the knowledge concerning the possibility of receiving and processing information, as well as the cognitive factor with regard to the operational capabilities of the simulator.

Current flight simulators are also treated as an essential tool for improving the skills of "automatic" performance of certain activities on board the aircraft, and the efficient reception and selection of signals – data and information. Many psychologists believe (Terelak, 1975) that in relatively simple situations habits can replace thinking – automatic execution of actions. In complex, unexpected situations, such as unusual aviation failures a very important role is played by rapid assessment of the situation and programming the appropriate actions.

The fact that aviation simulators, regardless of their class, are effective training tools is also confirmed by the results of studies conducted worldwide. *Research studies that have been conducted so far clearly confirm the usefulness of flight simulators, including the simplest (BITD), in the basic flight training. Lintern et al. analyzed, as part of their research, the degree of transferring the pilots' landing skills from the flight simulator to the training aircraft in the initial phase of flight training. The first group of pilots in training held two landing sessions landing using a flight simulator before the commencement of practical training in the air. The other group – the control group – did not have that kind of training prior to starting the practical training in the air. The investigators proved that the first group of trainees needed approx. 1.5 hours of flight training less before the first solo flight, in comparison with the other group, which had not had prior simulator training. In this case, we are only speaking of one particularly important and difficult element of flight training – learning to land (Lintern, Roscoe, Koncoe, Segal, 1990).*

Dennis and Harris, on the other hand, examined the effects of simulator training on the practical flight training using Microsoft Flight Simulator (v.4.0), which is a gaming program based on a personal computer (PC) For one hour, each trainee executed flight tasks, such as straight flight and coordinated turns. Then, the trainees commenced practical flight training. The results of comparative analyses of the results achieved by the trainees with prior simulator training with those who had not been subjected to such training explicitly confirmed that the first group more easily mastered the elements of the exercise which had been practiced earlier on the simulator. Furthermore, these studies confirmed the view that simple PC simulators are effective tools in the formation of the aviation skills in the initial phase of flight training (Harris, Harris, 1998).

On the other hand, the results of the research conducted by Vaden and Hall (Vaden, Hall, 200x) pointed out to the fact that the aircraft motion imitation platform does not perform a significant role in the acquisition of skills by the pilot. Using the meta-analysis method, they examined the impact of the aircraft's plane of motion, which is an integral part of the flight simulator, on the development of pilot skills. The research studies showed little effect of using this type of equipment on increasing the effects of flight training in relation to the transport aircraft pilots. They also pointed to

the fact that the costs related to the upgrading of the simulator with this function, as well as additional physical load of the pilot during the execution of exercises on the Full Flight simulator, have no significant effect on reducing the number of hours of practical flight training carried out by the flight crew in the air. On the other hand, they did not refer to the impact of this training on improving the skills of the crew in the use of the resources which were at the crew's disposal during the actual flight.

Interviews which the author conducted with a group of instructors from the air training centers in the Republic of Poland point to the fact that the FNPT-2 simulators provide high efficiency of training and screening, particularly in relation to exercises concerning IFR flight procedures and procedures used in emergency situations, aircraft maneuvers during air mission execution, as well as preflight activities in the aircraft cockpit.

Taking into account the above test results, it is possible to put forward a thesis that modern flight simulators provide a high degree of training efficiency in basic flight training of pilots.

The Polish Air Force Academy has more than thirty types of simulators which are used in basic and advanced training of aviation personnel, including simulators certified by the civil aviation authority. Their use is associated with acquainting novice pilots with the airplane, its handling technique, navigation and basic combat missions. They are used for the selection and training of pilot candidates (Fig. 9a, b), the advanced flight training, the training of all flight phases, the assessment of the execution of specific air missions, as well as training and integrating air crews during MCC and CRM trainings.

The flight training syllabus for PAFA pilot cadets includes 120 hours of simulator training during the four years of study. The situation is slightly different with regard to training / professional development of jet aircraft pilots in the Polish Armed Forces units. Apart from navigation and flight maneuver functions, simulators of that type also imitate the functions resulting from the combat missions executed. The number of hours of simulator training depends on the intensity and the type of tasks he performs within the scope of his duties.

In the aviation units, flight simulator is treated, apart from the application mentioned above, as a valuable tool preparing pilots for regaining currency in the event of long time between flights. In addition to the advantages related purely to the training, the use of simulators can significantly reduce training costs in comparison with the execution of the same training using the real aircraft. The US Air Force estimates that the cost of one hour of training on the C-5 aircraft is approx. \$ 10,000 whereas one hour of training using the C-5 simulator is \$ 500.

a)

MODERN TECHNOLOGIES – PRACTICAL TRAINING

In 2016, PAFA joined military centres training air personnel using equipment which is compatible with each other in terms of ergonomics from the basic to the advanced training level. Aircraft cockpits, from the general aviation level, through school-trainer aircraft, to airliners, are equipped with the newest generation of avionic equipment whose visualization is based on liquid-crystal displays. (Fig. 10) The method of data imaging, and operating the onboard equipment based on modern solutions, which can often be regarded as similar in terms of ergonomics, enables the pilot in training to move in the same, gradually enriched, interior (passenger aircraft cockpit) mission environment. This is particularly important for the aspects connected with the "workload" and / or situational awareness of the pilot.

It should be stressed that academic instruction and simulator training at different stages of training Polish Air Force Academy cadets is based on modern teaching / training systems. The Integrated Training System (ITS) should be considered to be the top achievement with that respect. In addition to the M-346 Aermacchi aircraft, it also includes a complete Ground Training System (GBTS) (Fig. 11). That system enables trainee pilots to undergo a full package of academic instruction and simulator training prior to practical in-flight exercises. Owing to the implementation of that system it is possible to improve the safety and the quality of training with simultaneous significant financial savings.

The integrated M-346 aircraft training system consists of the following components:

1. *Electronic classroom* – is a concept of using computer software to create applications for education and training. With regard to M-346, Electronic Classroom is an application called CBT (Computer Based Training). It contains chronologically and thematically arranged lessons in the following topics: aircraft systems, aerodynamics, navigation, and normal and emergency procedures. Students of the course are responsible for individual study under the specified daily schedule. CBT also includes supervision of lecturers, who, address the emerging questions with their knowledge and experience, and explain potential issues. The technology implemented in CBT uses 2D and 3D interactive models, including audio commentary guiding students through individual topics. Training management and learning progress are recorded in the Learning Management System, which also includes dedicated units to evaluate learning progress.

2. *Desktop Trainers / Simulated Based Training (SBT)* – is a concept of using a personal computer (desktop or laptop) to learn some elements of the knowledge about the aircraft and operating its systems. The most common format is the application that allows the trainee to practice operating the controls in the aircraft cockpit (e.g. operating the UFCP – Up-Front Control Panel and MFD – Multi Function Display). The application is limited to the presentation of the effects of the pilot's impact on individual systems or



b)



Figure 9 Comprehensive scientific-training system for pilot selection (a) and the ejection training device (b) at PAFA (Source: PAFA)

The advantage of simulators is undoubtedly enable pilots to perform simulated air missions and practise behaviour in emergency situations, the implementation of which on the trainer aircraft would involve a very high risk of an undesirable flight-related event. Another reason for the use of simulators in military aviation is the level of knowledge transfer, which is comparable with that acquired from flying actual aircraft. The results of research studies related to the areas connected with the effectiveness of simulator training clearly indicate that the knowledge, skills, and habits acquired during the training are directly reflected in the willingness of the pilot to perform the specific aviation tasks in the air. R. Moorman et al. conducted a study related to flight simulator knowledge transfer, which covered the period 1957-1986 (Terelak, 1975). Using meta-analysis, the authors conducted the studies, and their results have enabled them to find out that simulator training permanently leads to improving the training effects achieved by jet pilots, as much as practical air training using a specific aircraft type. This regularity, however, was not confirmed in relation to helicopter pilots. In another study, Corveta and Dunlap focused their research on the simulator training effectiveness taken by jet pilots, with respect to items such as landing manoeuvre, IFR flight, and performing tasks in a training area, such as bombing (Carreta, 2010). In all of the above-mentioned research areas the results clearly indicated a high usefulness of flight simulators with regard to the development of pilot skills.

a)



b)



c)



d)



Figure 10 The cockpits of Zlin (a), Orlik ATC II (b), M-346 (c), and F-16 (d) aircraft (Source: PAFA)



Figure 11 A comprehensive training system for M-346 aircraft pilots

(Source: Author's own work, developed on the basis of (internet sources))

aircraft control components (such as e.g. operating the navigation system), with the possibility of performing a flight or executing a mission, but with limited functionality and visualization.

3. *Training Management Information System (TMIS)* – IT system combining the operation of individual IT subsystems managing the M-346 training. Such subsystems include, among others: Integrated Logistic Support (ILS), elements of GBTS (Ground Based Training System), and Learning Management System (LMS). TMS designed to manage the following: training, the availability of aircraft, the use of simulators, planning training and maintenance activities involving the aircraft and other equipment.

4. *Mission Planning and Debriefing Stations (MPDS)* — common tool used for supporting the M-346 aircraft as well as FMS and FTD simulators. It supports planning, briefing, and uploading the mission planned on a memory card. The data is then uploaded on the aircraft or simulators. They are the basis for setting the aircraft's systems and determine a scenario according to which a flight is performed. MPDS comprise a workstation with a single or multiple screens, wall projection displays, and space planning and debriefing. MPDS is the basic component which manages the planning, debriefing and evaluating the trainee.

5. *Real Time Monitoring Station (RTMS)* – enables real-time monitoring of the task being performed, and its modification from the ground through a Data Link. RTMS technology in conjunction with LVC and Data Link also enables conducting formation flights which combine the use of simulators and real aircraft.

6. *Instructor Operating Station (IOS)* – FMS or FTD simulator workstation which manages training and mission execution. The station is equipped with controls to allow the instructor to take over the control from the student in order to demonstrate and training component. In addition, the station allows the instructor to introduce a target aircraft or an aircraft to fly in a formation, which are piloted by the

instructor using the controls located on the console station. Mission management enables to declare the assumed meteorological and tactical conditions, as well as conditions related to the systems of the aircraft.

7. *Operational Flight Trainer (OFT) / Flight Training Device (FTD) / Part Task Trainer (PTT)* – part-task simulator used to familiarize the trainee with the aircraft systems, and to train aircraft handling in VFR / IFR navigation flights, emergency procedures, and, in conjunction with the FMS, to serve as a platform for formation flights and the implementation of tactical scenarios. It is characterized by excellent graphics and user-friendly interface but, in comparison with FMS, it has a limited field of vertical and horizontal visualization (120/60 degrees).

8. *Full Mission Simulator (FMS)* is an example of the highest level of virtual technology implementation in flight training. Using it, it is possible to imitate, in a 1:1 ratio (considering the realness of training), all flight and training phases, including sensor integration (Fire Control Radar, Targeting Pod, Electronic Warfare System, Data Link), in order to create complex tactical scenarios. This helps reduce training costs and increase the availability of aircraft for other tasks. FMS enables to perform, among others, flights in the formation of two and four aircraft, offensive and defensive manoeuvring in dog fight using weapons, to perform tasks using a radar and a targeting pod, perform strike missions using weapons, to fly in NVG (Night Vision Goggles), and using HMD (Helmet Mounted Device). In combination with the FTD, the FMS simulator is able to carry out the formation tasks. Furthermore, the FMS and FTD with LVC technology (Live Virtual Constructive based on Data Link and ETTS) and the use of RTMS (Real Time Monitoring Station) are capable of performing tasks simultaneously in connection with real aircraft executing an air mission [internet sources].

The system described above combines the functions of a basic and an advanced training subsystems, and a subsystem for training pilots who are in the so-called continuous training. Elements of the system fully secure various training stages with regard to academic instruction and practical simulator training. In the Polish Air Force Academy, this system will be used in the third stage of training (Fig. 2), for cadets who are candidates for F-16 jet pilots.

CONCLUSION

The introduction of modern aviation technology has led to the rapid development of training tools commonly used in academic instruction, and in both simulator and practical air training. At present, it is difficult to imagine the training for aviation personnel without this type of training tools. Despite the fact that such training devices are usually expensive, their advantages have caused them to become common training tools. These devices are particularly useful in enhancing the pilot (aircraft crew)-machine (aircraft) cooperation. The relatively low cost of reconfiguring

simulation devices causes that they faithfully imitate the cockpits of aircraft used in air operations, and thus allow the pilot, aircraft mechanic, or air traffic controller to achieve a high level of adaptation to acting in a new mission environment task, which is particularly important from the perspective of the complexity and high dynamics of the mission environment variation affecting the above-mentioned air personnel. These activities are additionally supported by the utilization of modern technologies (e.g. control automation, glass-cockpits, etc.) in all aircraft types used at all stages of flight training. Because of all these advantages, aircraft manufacturers, more and more frequently offer comprehensive training systems for pilots (M-346), or aircraft mechanics (F-16), at the same time not forgetting the simplest training devices from today's perspective – BITD.

REFERENCES

- [1] Błoczyński, R. (1976). "Psychologia lotnicza – wybrane problemy". BWW, Warszawa,
- [2] Carreta, T.R., (2010). "Transfer of training effectiveness in flight simulation: 1986-1997 (Technical Report AFRL-HE-AZ-TR-1998-0078)". Mesa, AZ: U.S. Air Force Research Laboratory, Human Effectiveness Directorate, (in:) Marlussen M., Hunter D.R., Aviation psychology and human factors. CRC Press, New York,
- [3] Delors, J. (1998). "Edukacja. Jest w niej ukryty skarb". Stowarzyszenie Oświatowców Polskich Wydawnictwa UNESCO, Warszawa,
- [4] Harris, K.A., Harris D. (1998). "Computer-based simulation as an adjunct to ab initio flight training". International Journal of Aviation Psychology No 8/1998,
- [5] Kozuba, J. (2013). "Selected aspects of forming pilot situational awareness". PAFA, Dęblin,
- [6] Lintern, G., Roscoe S.N., Koncoe J.M., Segal L.D., (1990). "Transfer of landing skills i beginning flight training". Human Factor No 32/1990,
- [7] Pielacha, R. (1994). "Imitatory kierowania samolotami w kształtowaniu nawigatorów wojskowych". Research Study, PAFA, Dęblin, in: Leszczyński, R. "System selekcji kandydatów do Sił Powietrznych". Research Study, PAFA, Dęblin,
- [8] Stelęgowski, A., Kłossowski M., Wochoński Z. (2011). "Wpływ ćwiczeń na lotniczych gimnastycznych przyrządach specjalnych (LGPS) na sprawność motoryczną i skład ciała". WIML, Polski Przegląd Medycyny i Psychologii Lotniczej No 1/ Vol.17/2011,
- [9] Terelak, J. (1975). "Higiena psychiczna i pilot". MON, Warszawa,

[10] Vaden, E.A., Hall, S. (2005). "The effect of simulation platform motion on pilot training transfer: A meta-analysis". *International Journal of Aviation Psychology* No 15/2005.

[11] <http://www.leonardocompany.com/en/-/gbts>, access on. 10th January, 2010,

[12] <http://www.m-346.com/m-346/szkolenie-pilotow/system-etts>, access on 10th October, 2016,

[13] <http://www.m-346.com/dla-mediow/galeria-zdjec/m-346-szkolenie/category/5-szkolenie>, access on 10th October, 2016,

[14] <http://www.m-346.com/m-346/szkolenie-pilotow/system-gbts>, access on 10th October, 2016,

[15] <http://www.wiml.waw.pl/node/90>, access on 3rd February, 2011.

AUTHOR INFORMATION

Jarosław Kozuba, Professor PAFA, Vice-Rector for Science, National Security and Logistics Department, Polish Air Force Academy, Poland

EVALUATION OF ASYMPTOTIC LEARNING OF OPERATOR – PILOT IN SYMBIOTIC SIMULATOR ENVIRONMENT

Pavol KURDEL

Department of Avionics, Faculty of Aeronautics, Technical University of Košice, Slovakia

Pavol.kurdel@tuke.sk

Tobias LAZAR

Department of Avionics, Faculty of Aeronautics, Technical University of Košice, Slovakia

Tobias.lazar@tuke.sk

Alena NOVÁK SEDLÁČKOVÁ

Air Transport Department, University of Žilina, Slovakia

Alena.sedlackova@fpedas.uniza.sk

Abstract - The paper provides a scheme of basic methods in use which accept the concept of symbiotic principles in the research of operator – pilot skills in artificial and natural environments. New aviation technology is designed in concord with the principles of converted information of the use of aviation technology. Handling and control of sophisticated flying apparatuses require increased demands on operator – pilots learning. Considering high price and safety of aviation technology, the requirements on the preparation of technical flight operators are increasing too. Motivation and the answer to the above mentioned problems require the implementation of methods which can state the reasons of such requirements as the basic attribute in the human reaction to possible system and random errors in a scientific way. The paper presents a suggestion of basic used methods which have been implemented in the research of skills in the environment which has been specially designed for the solution and looking for answers to the connection of individual operator skill of operator – pilot with the concept of construction ability of a flying apparatus.

Key words - asymptotic learning, skill, mathematical models, evaluation of locomotion skills.

BACKGROUND

Currently, the most common feature in the field of civil aviation is the safety. This scientific area is very important for many research institutes. In the Slovakia are interested in this field Department of Avionics, Technical University of Kosice and Air Transport Department in cooperation with

Flight Training Organization (Approved training organisation –SK.ATO.01) – Air School of the University of Zilina. [9] They research this area in the view of the impact of a human factor on safety, the flight-checking and verification of technical equipment and their quality as well as the relationship of the operator/pilot and the aircraft. An important part of the research is the application of results in practice and in the teaching process at the universities, too. Students should be educated comprehensively, they need to have a knowledge and very good technical background but also the aviation legislation (air law) is necessary, because that provides a framework for all activities in civil aviation. Thus prepared student-researcher can be a part of next theoretical and practical simulations that will lead to increasing the safety and quality of civil aviation. [10].

During the flight, the unique mission of the operator - pilot (OP) lies within the responsibility for the selected or programme-determined doctrine of the aircraft position along the flight trajectory. The mutuality of the relationship of the OP and aircraft completes the image of the ergatic system, in which the OP is tied to the object (aircraft). The operator – pilot makes a decision about the optimization of the aircraft control in complex flight situations in which the aircraft might find itself. During the flight, the OP decides about the change of aircraft control to manual one, which is the main feature of the selective method of the performance

of flight ergatic system control along the determined flight trajectory [3]. The space which will further on be called an area of successful task solution (ASS) is the final solution of aircraft operation along the selected route. As it follows from the above presented short description, the quality of control (automated) and the control of board information systems of the aircraft by the operator – pilot decides about the total effectiveness of aircraft control along the determined flyway. Then, finishing the flight can be evaluated as a successful one once the determined conditions, which can be finally evaluated as successful ones, are met or as an unsuccessful one if the conditions for control quality are not met. Because quality presents the mutuality of internal ties working in the aviation ergatic system (AES), the term of local quality estimation will be used as follows [7]. Local estimation is tied to one cycle from N – number of controls (see Figure 2), for which the following is valid:

$$\hat{P}\{Xq \leq Q_{ASS}\} \rightarrow P, \quad (1)$$

where:

Xq – coordinates of AES position in Q_{ASS}

Q_{ASS} – area of successful solution of the flight task

P – obtained probability of Q_{ASS} position

It follows the above presented assumption (1) that it is necessary to consider procedures which enable to calculate the variable of the estimation of learning and determine the area of successful solutions QASS when estimating the local quality of the control of the aircraft by the OP [1].

It is well-known that learning of flight ergatic systems (controlled by a human) is connected with the notion of „saturation“, where the learning curve has exponential character. The condition is that every control cycle and every AES position along the flight trajectory has a random variable function assigned, which possesses the following characteristics [2]:

$$q(i) = \begin{cases} 1, & \text{when } Xq \in Q_{ASS}, \text{ e. g. success} \\ 0, & \text{when } Xq \notin Q_{ASS}, \text{ e. g. failure} \end{cases}$$

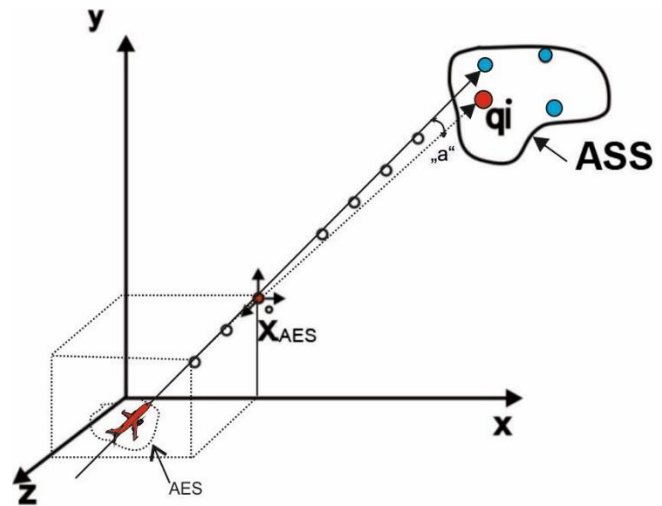

Figure1: Coordinates of the position of reaching the element q_i in the area Q_{ASS} on a flying apparatus controlled by an operator - pilot. (OP) (Source:[1])

1. ESTIMATION OF LEARNING SUCCESS OF THE OP TO CONTROL AES

The above described images of the OP quality in the control of ergatic system can be represented by a sequence of estimation variable $y(i)$, number of N – cycles of OP’s interventions into the control of ergatic system [4]. It is supposed that the positioning of the ergatic system saturated in space-time has a programme-like character. The equation (1) can be expressed by a recurrent relationship of the following type:

$$y(i) = a \cdot y(i - 1) - (1 - a) \cdot q_i \quad (2)$$

where:

$y(i)$ – presents the estimation of aircraft control quality,

a - presents informative parameter by which OP’s motivation for the control of the ergatic complex and positioning of ergatic complex control are connected.

The content of the time constant „T“ which is the time constant of the ergatic complex is the source of information. Figure 2 shows suitable expression of the meaning of the parameter „a“.

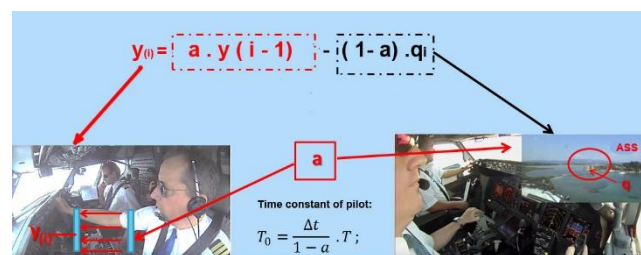

Figure 2: Image expression of the recurrent equation with the expression of parameter of importance parameter (Source:[1])

a- Presents the ability of the pilot to perceive the features of the control object in the space-time. Perception of the OP's information ability is supported by the avionic complex which is decisive for the aircraft constant T [7].

The equation (2) presents a recurrent equation of the ergatic process when solving a task of observing the position $[[q_i]]_{ASS}$. It is determined that if:

$q_{i_{ASS}} = 1$, and the vector control function [0] is $F \subset Q_{O_{ASS}}$

$q_{i_{ASS}} = 0$, and the vector control function [0] is $F \not\subset Q_{ASS}$

It is supposed that the informative character of the parameter „a“ lies within the area:

$$0,5 \leq a \leq 1 \quad (3)$$

It is possible to determine the limit positioning of ergatic system into QASS according to the character (3) by the following probability:

$$P(q_i = 1) = p_i$$

$$P(q_i = 0) = 1 - p_i$$

It is possible to estimate the importance of the recurrent equation depending on those values from the equation (2) exactly [5].

Let the ties of the operator – pilot and the controlled object be determined by the relationship of OP's time constant T_0 and time constant T – of the flying object (controlled). The ties are defined as follows:

$$T_0 = \frac{\Delta t}{1-a} \cdot T; \quad (4)$$

It is supposed that „a“ is determined by the relationship

$$a = 1 - \frac{4 \cdot \tau_{x=0}}{T};$$

where:

τ_x - presents the time outside the programme-determined flight trajectory.

Based on those considerations it is possible to determine a discrete graph of object control, Figure 3.

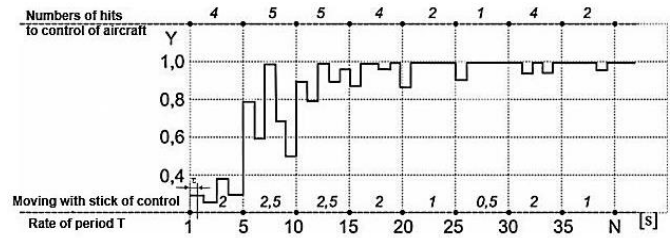

Figure 3: Position of the aircraft control stick by the operator – pilot in the determined range of N – cycles of AES control (Source: Authors)

The presented consideration allows to perform a recurrent equation (2) transformation into a differential one in the following form:

$$T_0 \cdot \dot{y}(t) + y(t) = q_i(t) \quad (5)$$

The problem presented here has been realised as a programme and in practice in the conditions of a lab workplace on the simulator provided by the company Virtual reality media Ltd. Comparison of obtained results has been performed by the method of simulation according to the following scheme [8].

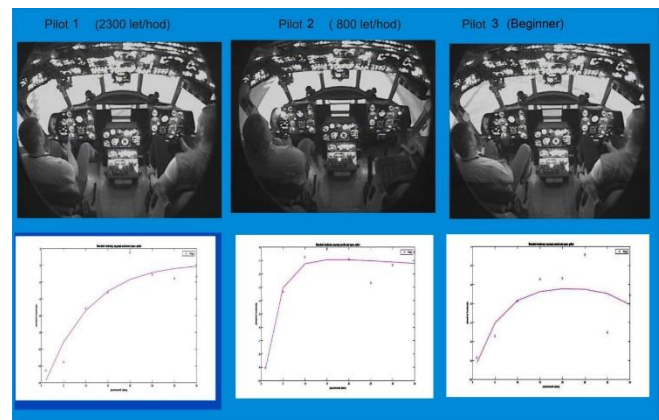

Figure 4: Estimation of learning success of the operator – pilot to control AES according to the training degree (Source: Authors)

Output data in Figure 4 offer mean values of the data of average values of helicopter longitudinal slope angle interleft with characteristics continuous course. The analysis of graphic courses shows that the output of pilot No. 1 (professional, 2500 flight hours) during the period of 35s has an exponentially growing course, at the end the helicopter position is stabilised on the value of longitudinal slope angle 0°, which is an ideal case for further completion of the navigation task (flight circuit according to valid legislation regulations). [1][5]

The output of the pilot No.2 (800 flight hours) also has exponential course with faster onset but the value of longitudinal slope angle on the edge of the area of successful task solution within 35s is not stabilized precisely on the value 0°. The comparison clearly shows that this part of methodological research is essential and highlights the skills of both pilots obtained by continuous learning and practical training. Within observed 35s, the beginner pilot could not reach the required longitudinal slope position and the following fulfilment of the navigation task has been impossible. This situation fully illustrates the lack of obtained skills of the paper authors.

2. ANALYSIS OF OP'S LEARNING SUCCESS TO CONTROL AES

On the base of analysis in the programme environment of matlab the following has been obtained:

The graphs of asymptotic course of successful obtaining ASS (Figure 4) have only theoretical and educational importance. Objective measurements and OP's learning experience have shown that when an individual is learning how to control an aircraft there occurs so-called variable delay which influences the effect of its quality. The model of the variable delay, which has been used in the research of OP's skill, can be expressed by a programme, the part of which contains the model of aircraft control stick positioning during AES control (Figure 3).

Models of ergatic systems are used in the design of specific AES and their adequacy is verified in the process of their realisation. A particular ergatic process is usually performed with the help of simulators. The computer systems of contemporary and perspective simulators contain the architectures of hybrid information systems. Due to the above mentioned reason, the analogue as well as discrete methods of the estimation of ergatic systems parametric sensitivity do not cease to possess practical importance [5].

Next, the attention is devoted to the model of the ergatic system, by the function of which compensation process is realised by the control of AES by the operator – pilot and with the influence of outer errors. There is defined compensation role aimed at:

- a) the OP's skill in the compensation of the influence of errors implemented into the selected board information system - simulator,
- b) the definition of the recommendations, constraints and limits of OP's compensation skills,
- c) the possibilities of compensation errors which influence the position of AES on the flight trajectory.

The mutuality of the mathematical model and the object of modeling is complex and technically it presents problems which are hard to solve. The reason of such complexity are the effects of the doctrinal solutions of the situations by the OP.

Designing a symbiotic system, which is determined for testing and control of flight professionals to prove their ability to control and operate avionics technology at the

Department of Avionics is the proof of this hypothesis. The base of the symbiotic system is the processional mutuality of digital systems in the control of the aircraft, the meaning of which is solving of complex functions of the tasks being solved during the flight. It is possible to perform measurements for finding out the degree of professionalism of the operators as well as the recommendations for the evaluation of their effectiveness in connection with other systems. The system has been designed and constructed on the base of theoretical postulates and financial means of the author of [1].

CONCLUSION

Basic features of a symbiotic system are determined by a mathematical model (analogue, linear, discrete, hybrid), which empirically absorb the experience with AES control. The system is based on the use of probability estimation method to obtain statistic data. This method is intrinsic to many methods of model design. The experience from recent model creation can in short be concluded into the following points:

1. By the research of OP's reactions to a determined stimulus, a hypothesis of the structure of a heuristic model is created, i.e. a differential equation succession, from which transfer function is created, is determined. In the process of simulation, model parameters are gradually set and a measuring element, which imitates the variable delay in the controls positioning by the OP, is included. It is gainful to set the simulation circuit to be performed by the following methods:

- a) with the help of well-known experimental methods of object identification,
- b) by the use of well-known (or determined) criteria, e.g. system sensitivity to the change of parameters. It is suitable to find dominant values of time increases which are evoked by the hypothesized transfer function or the deviation from determined value,
- c) by the use of other models which are connected into the simulation circuit depending on the ability of the human to adapt to a new board electronic system, which is the object of the examination.

2. Stability of the characteristics of OP's learning is created by AES heuristic model and uses statistic terms. Ergatic (error) process is at the same time defined by a stationary function. Similarly, the above mentioned heuristic model, Figure 6, can be named as well. Then it is possible to determine the quality of functions and the effectiveness of OP's learning identification by the methods used in the theory of control.

REFERENCES

- [1] KURDEL, P.: Vedecko-pedagogické aspekty experimentu a modelovania so zložitými leteckými systémami, Habilitačná práca, Košice 2016.
- [2] TARAN, V. A. Ergaticeskije sistemy upravlenija. Moskva: Mašinostrojenie 1976

- [3] ARAMANOVIČ, J. G., LUNC, G. L., ELSGOES, L. C.: Funkcia komplexnej premennej, operátorový počet, teória stability. Bratislava: Alfa 1973, s. 169 – 184
- [4] KELEMEN, M., LAZAR, T., KLECUN, R.: Ergatické systémy a bezpečnosť v letectve, Edukácia a inteligencia zručností v leteckej prevádzke. Liptovský Mikuláš: Akadémia ozbrojených síl generála M.R. Štefánika 2009, 316 s. ISBN 978-80-8040-383-6.
- [5] ŠVEC, J., KOTEK, Z. : Teórie automatického řízení. Praha: SNTL 1969, 460 s
- [6] ZÍTEK, P.: Simulace dynamických systémů. Praha: SNTL 1990.
- [7] KALAVSKÝ, P., ROZENBERG, R., SOCHA, L., SOCHA, V.: Hodnotenie výkonnosti - 2016. In: Zvyšovanie bezpečnosti a kvality v civilnom letectve 2016. - Žilina : EDIS, 2016 S. 85-89. - ISBN 978-80-554-1143-9
- [8] BENKO, M.: Identifikácia kvality leteckého ergatického system, Diplomová práca 2016, TUKE.
- [9] NOVÁK, A.: Výskumné a vzdelávacie laboratória Katedry leteckej dopravy Žilinskej univerzity v Žiline, In: New trends in civil aviation 2016 : Žilina, 22. September 2016. - Žilina: Žilinská univerzita, 2016. - ISBN 978-80-554-1252-8. - S. 60-63.
- [10] TOMOVÁ, A., HAVEL, K.: Potrebujeme vzdelávanie leteckých odborníkov v anglickom jazyku!(?) In:

Zvyšovanie bezpečnosti a kvality v civilnom letectve 2016- Žilinská univerzita, 2016. - ISBN 978-80-554-1143-9. - S. 121-125.

ACKNOWLEDGEMENT

This paper has been created following the project in the process of solution which has been co-financed by the EU sources entitled „ Centre of Excellence for Air Transport Centrum- ITMS 26220120065.“



AUTHOR INFORMATION

Pavol Kurdel, Assoc. Professor, Department of Avionics, Faculty of Aeronautics, Technical University of Košice, Slovakia

Tobiáš Lazar, Professor, Department of Avionics, Faculty of Aeronautics, Technical University of Košice, Slovakia

Alena Novák Sedláčková, assoc. prof., Air Transport Department, University of Žilina, Slovakia

USE OF SPLIT TRAILING EDGES OF AILERONS AND THEIR IMPACT ON NUMERICAL ANALYSIS OF FLUENT AIR STREAM REFER TO POLISH JET TRAINER AIRCRAFT T3-11 SPARK

Phd Eng Tomasz Łusiak

Department of Airframe and Engine, Polish Air Force Academy, Poland
t.lusiak@wsosp.pl

prof Andrej Novak

Department of Air Transport, University of Zilina, Slovak Republic
andrej.novak@fpedas.uniza.sk

Eng Aleksandra Piasecka

Polish Air Force Academy, Poland
olapiasecka5@gmail.com

Msc Eng Adam Dziubiński

Institute of Aviation in Warsaw, Poland
YetiSoft@poczta.fm

Abstract – TS-11 has become operational, students were able to practice more advanced tasks like interceptions, shootings and bombings. In addition, that made a huge step for future fighter pilots. From that time students were not only learning how to fly a jet but moreover how to deploy a weapon. SPARK found use also in maintaining pilots flying skills in frontline units due to low operating costs. Some versions of the aircraft were equipped with a camera so the reconnaissance missions became more efficient. It is our Polish construction and it flies in Polish Air Force over 50 years so we are doubly proud of it.

SPARK's flight took place on the 5th of February 1960 with Andrzej Ablamowicz in charge. The two next prototypes (110PR-03 and 111PR-04) were flown in March and July 1961. Both of them had installed Polish engines made in Rzeszów named WSK HO-10 (7,74kN). All the flying trials showed that Iskra was stable, easy to fly and maintain and what was very important - the flutter did not appear even in full range of allowed speed. In 1964 there was installed another Polish engine - SO1 (9,8kN). It produced about 25% more thrust than WSK HO - 10 from Rzeszów. Series production of SO1 began in 1967 and the first Iskra with this engine left WSK - Mielec factory on 31st of December 1968 [7], [8].

Key words – numerical analysis, CFD fluent, Airframe.

INTRODUCTION

The TS-11 "SPARK" was developed to fill the technological gap between piston engine aircrafts used for the training and modern jets from MIG family used by fighter units in Poland of XX century. In 1959 doc. Tadeusz Sołtyk and his team constructed a light dual seat jet trainer. Iskra made its first flight in 1961 so the gap was fulfilled. It was the first jet aircraft designed in Poland. The first prototype (119PR-02) was powered by 7,8kN British engine called Viper 8. First



Figure 1 – TS-11 ‘ SPARK’

The All of SPARK aircrafts flying nowadays are powered by one engine of 1000 kG thrust (SO-3) or 1100 kG (SO-3W) with speed of 700 km/h. The aircraft is able to operate from unprepared runways and is quite resistant to FOD (Foreign Object Damage) as well as its service has been simplified. Although the construction is totally metal aircraft has got a great performance and long gliding distance thanks to wide wingspan and light weight.

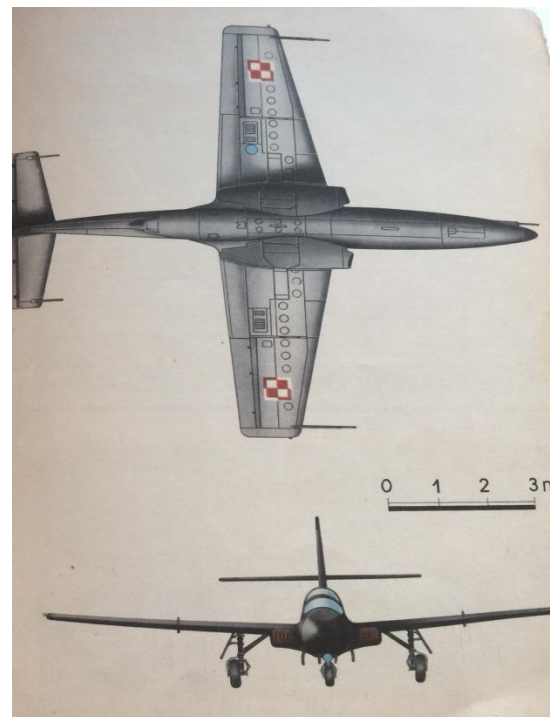

Figure 2 – TS-11 ‘ SPARK’

One of the most interesting aspects about SPARK construction is its ailerons. Ailerons form about 40% of wing's span and about 25% of wing's chord length. They can swing up by about 20 degrees and swing down by 5-10 degrees. Ailerons do not touch wing tips, therefore the buffeting phenomenon on the ailerons doesn't rise. Ailerons installed on SPARK's wings are marked with dull and split trailing edges. There is no option of too rapid detachment of circumfluent air stream. Constructor Tadeusz Sołtyk knew 'buffeting' phenomenon and he prevented that problem on TS-11 SPARK. Buffeting is caused by detached vortex which produces pressure changes. If the circumfluent air stream is right the drag and energy loss are lower.



Figure 3 – Ailerons of SPARK

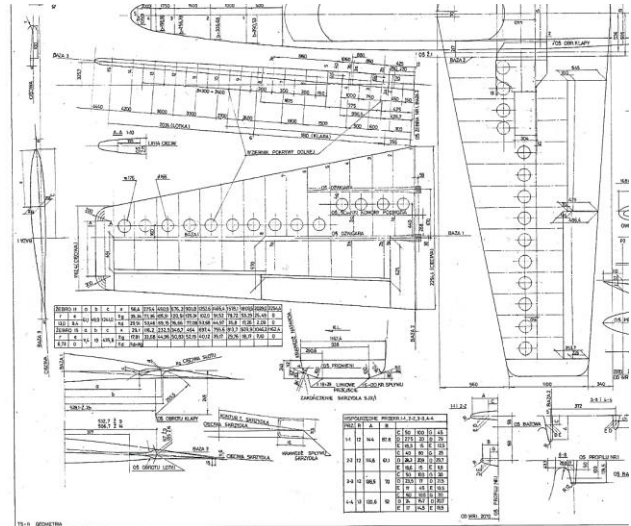

Figure 4 – Geometry of wing

Even minor vortex can cause vibration which is bad for controls and uncomfortable for the pilot who feels specific ‘buzz’ on controls. Split trailing edge prevents it because pressure changes do not make aileron hinge moment. Such solution is not so popular. There are only a few aircraft on which it was applied.

CFD ANALYSIS OF PZL TS-11 SPARK’S WING

Drawings of PZL Mielec TS-11 „Iskra” aircrafts geometry have been published by „Modelarz” in 2007. Geometry is depicted from factory drawings of theoretical (baseline) geometry of the aircraft. Most of the wing geometry is presented in table form describing the crucial theoretic points positions and parameters change along wingspan. Crucial to aerodynamics of the aircraft features are shown with precise dimensions, i. e.:

- Size and shape of the closing wall at the end of ailerons and flaps, which is different for each of those surfaces.
- Stall fences
- Flap, its gap shape, axis of rotation and range of extension
- Aileron, its nose shape, range of extension

Drawing includes also the theoretical shapes of fuselage, tail surfaces and engine inlets, not used in this work.

GEOMETRY

In this paper a theoretical geometry of wing, including the part submerged inside fuselage, has been used.



Figure 5 – CFD Geometry of wing

AIRFOILS

The airfoils used on this wing are not exactly the same as their theoretical contours, especially for NACA 64009. In the comparison below in order to show differences, the scale in the y direction has been exaggerated.

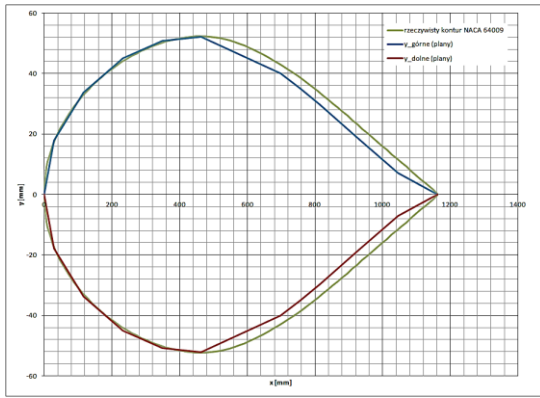

Figure 6 – CFD Geometry of wing

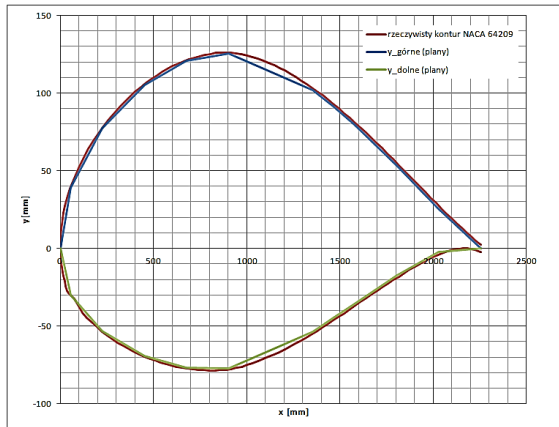

Figure 7 – CFD Geometry of wing

In 3D model the theoretical contours of airfoils have been used because of their better resolution.

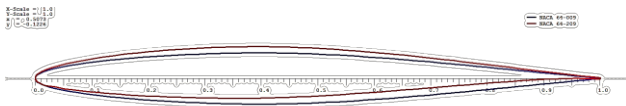

Figure 8 – CFD Geometry of wing

COMPUTATIONAL MESH

Tetrahedral mesh with prismatic boundary layer area.,
 $2.2 \cdot 10^6$ elements, Y^+ parameter size of 1.

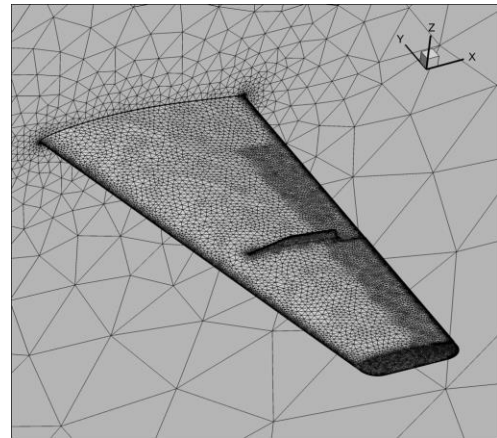

Figure 9 – CFD Geometry of wing

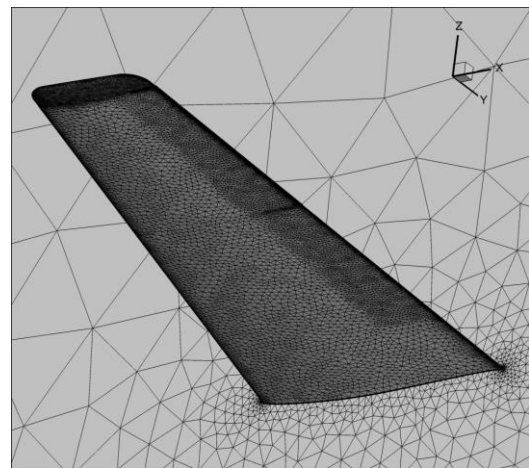

Figure 10 – CFD Geometry of wing

COMPUTATIONAL MESH

In order to obtain Y^+ size of 1.0, in the boundary layer

area, few layers of prismatic elements have been generated. The following parameters have been used:

- First element height h
- Number of layers $n = 18$
- Increase of height between layers parameter $|h + \Delta h|/|h| = 1.2$

High density of the mesh has been defined on leading and trailing edges, on external contour of stall fence, and in the area of airfoils root and tip.

The gaps between wing and aileron and flaps (both nose and side) have been omitted in order to simplify the geometry. Its influence is planned to be investigated in next stage of this work.

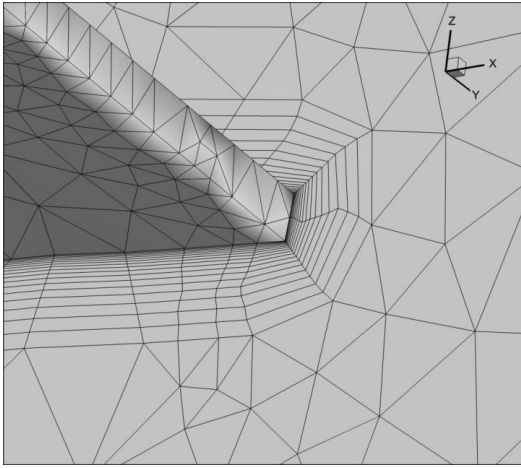

Figure 10 – CFD Geometry of wing - Boundary layer

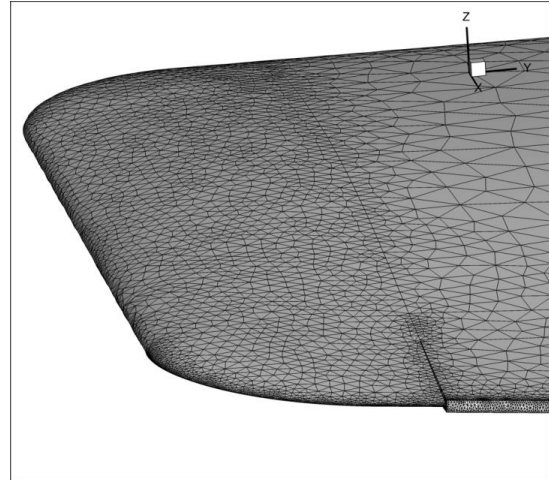

Figure 13 – CFD Geometry of wing - Wingtip

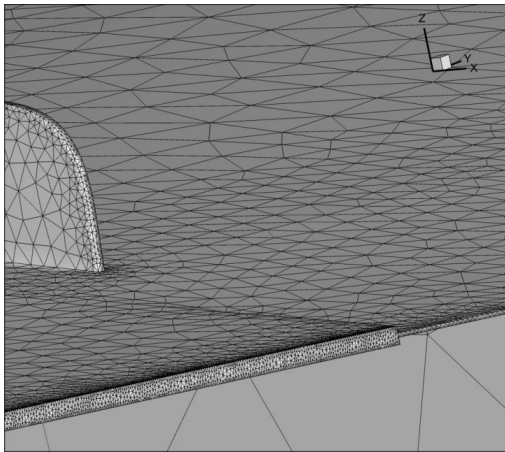

Figure 11 – CFD Geometry of wing - Change of trailing edge height between flap and aileron

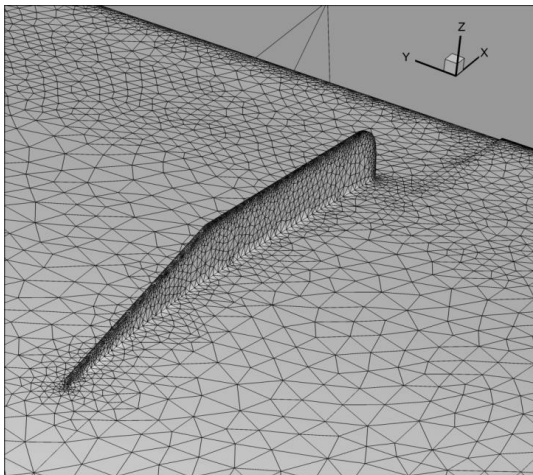

Figure 12 – CFD Geometry of wing - Stall Fence

RESULTS OF CFD FLUENT CALCULATION

Reverse flow areas shown with positive components of wall shear in x (longitudinal) direction on the wing surface.

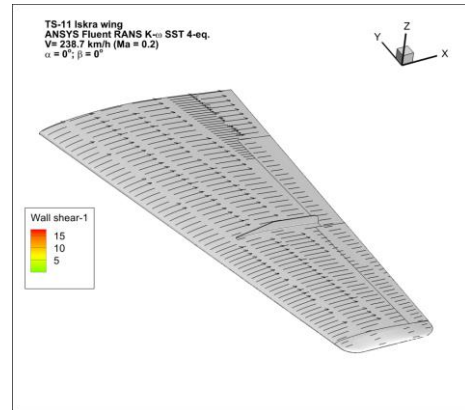

Figure 14 – CFD fluent - wall shear in x (longitudinal) direction on the wing surface, $\alpha=0^\circ$

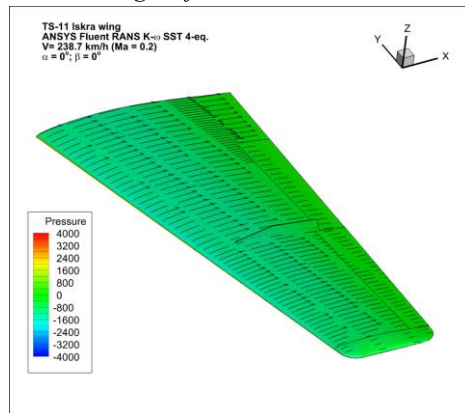

Figure 15 – CFD fluent - Pressure distribution and path lines, $\alpha=0^\circ$

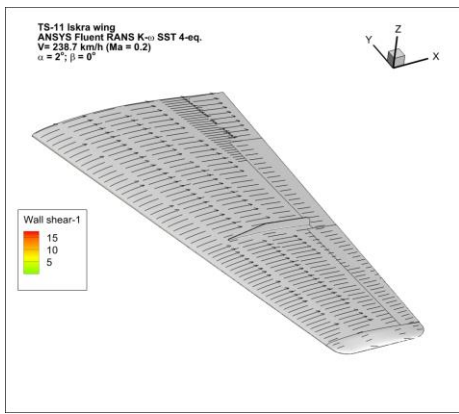

Figure 16 – CFD fluent - wall shear in x (longitudinal)

direction on the wing surface, $\alpha=2^\circ$

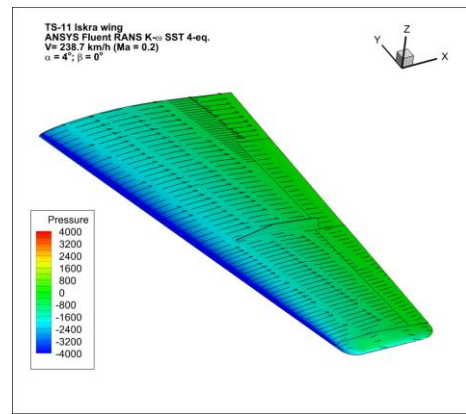

Figure 19 – CFD fluent - Pressure distribution and path lines, $\alpha=4^\circ$

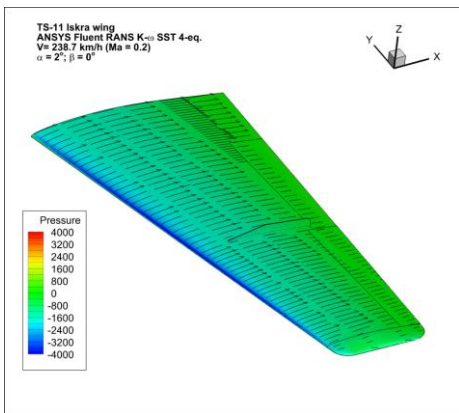

Figure 17 – CFD fluent - Pressure distribution and path lines, $\alpha=2^\circ$

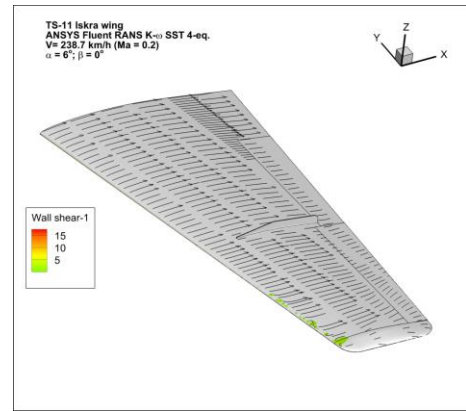

Figure 20 – CFD fluent - wall shear in x (longitudinal) direction on the wing surface, $\alpha=6^\circ$

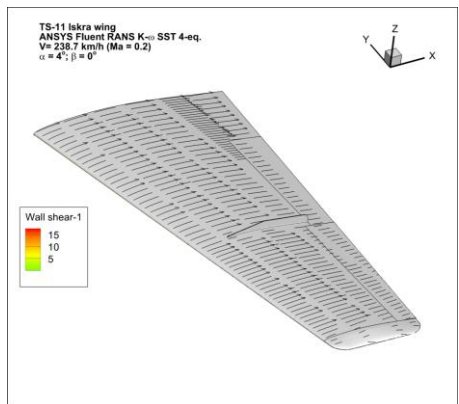

Figure 18 – CFD fluent - wall shear in x (longitudinal) direction on the wing surface, $\alpha=4^\circ$

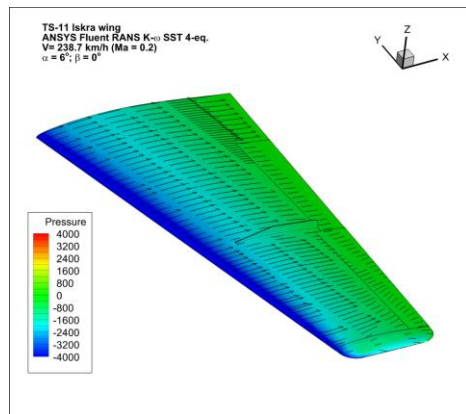

Figure 21 – CFD fluent - Pressure distribution and path lines, $\alpha=6^\circ$

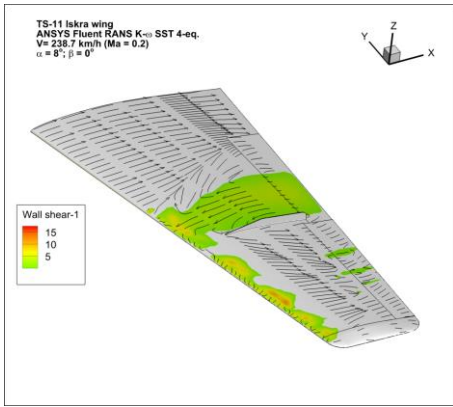

Figure 22 – CFD fluent - wall shear in x (longitudal) direction on the wing surface, $\alpha=8^\circ$

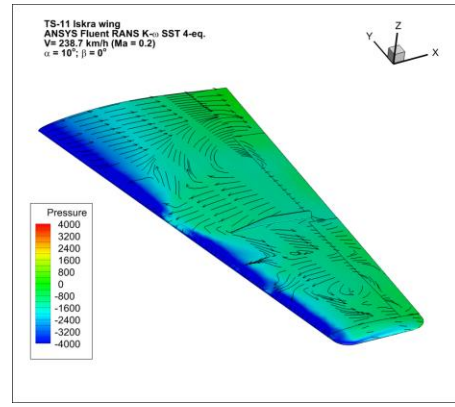

Figure 25 – CFD fluent - Pressure distribution and path lines, $\alpha=10^\circ$

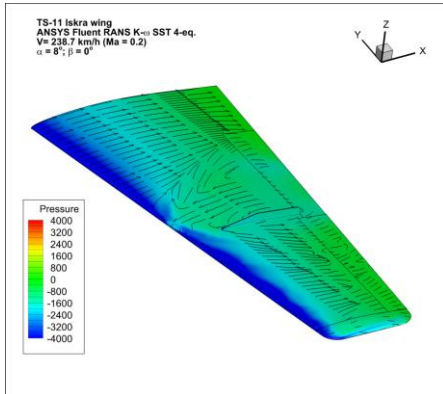

Figure 23 – CFD fluent - Pressure distribution and path lines, $\alpha=8^\circ$

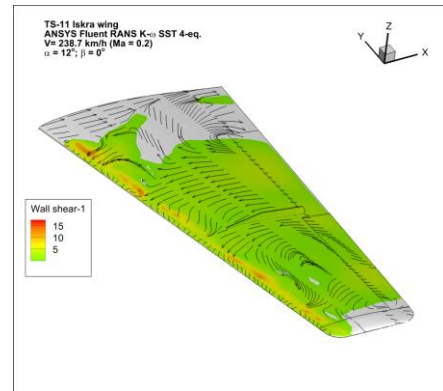

Figure 26 – CFD fluent - wall shear in x (longitudal) direction on the wing surface, $\alpha=12^\circ$

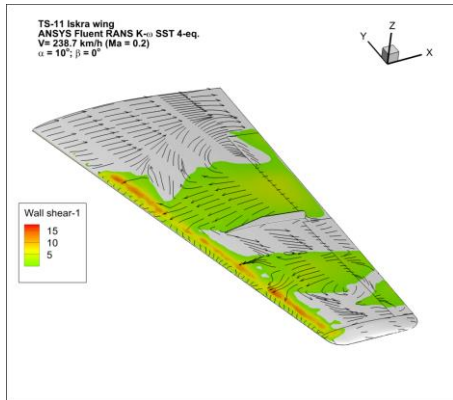

Figure 24 – CFD fluent - wall shear in x (longitudal) direction on the wing surface, $\alpha=10^\circ$

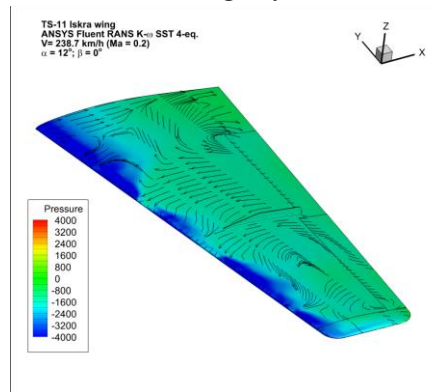

Figure 27 – CFD fluent - Pressure distribution and path lines, $\alpha=12^\circ$

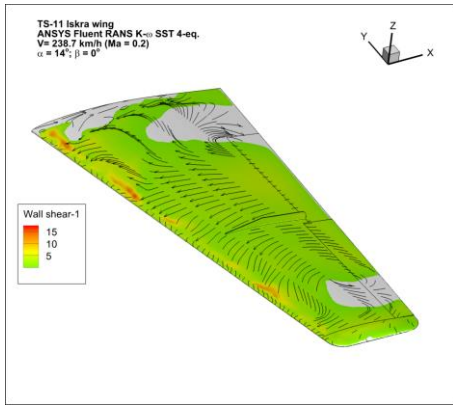

Figure 28 – CFD fluent - wall shear in x (longitudal)

direction on the wing surface, $\alpha=14^\circ$

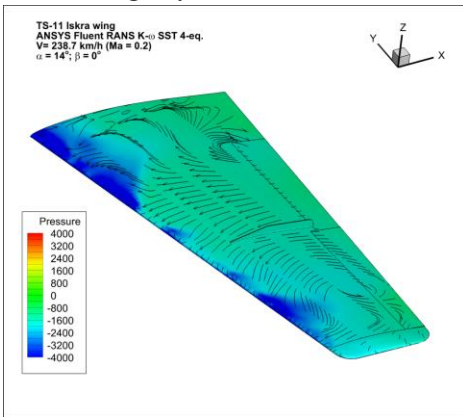

Figure 29 – CFD fluent - Pressure distribution and

path lines, $\alpha=14^\circ$

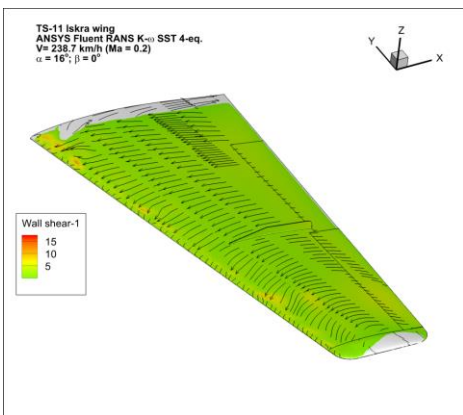

Figure 30 – CFD fluent - wall shear in x (longitudal)

direction on the wing surface, $\alpha=16^\circ$

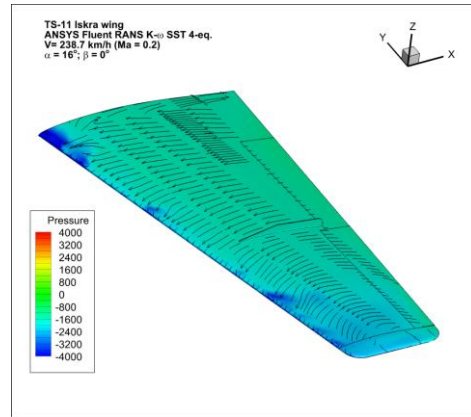

Figure 31 – CFD fluent - Pressure distribution and

path lines, $\alpha=16^\circ$

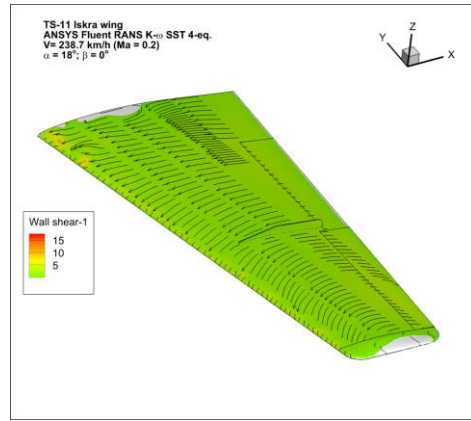

Figure 32 – CFD fluent - wall shear in x (longitudal)

direction on the wing surface, $\alpha=18^\circ$

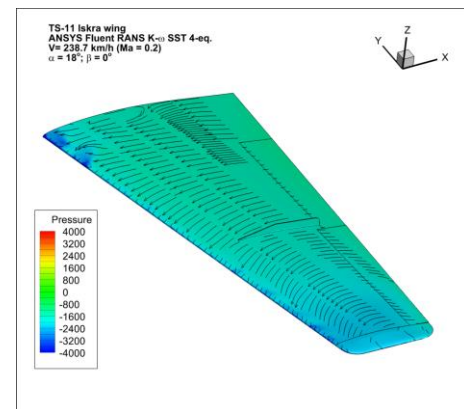

Figure 33 – CFD fluent - Pressure distribution and

path lines, $\alpha=18^\circ$

CONCLUSION

The paper presents numerical analysis CFD fluent which present the figure 34.

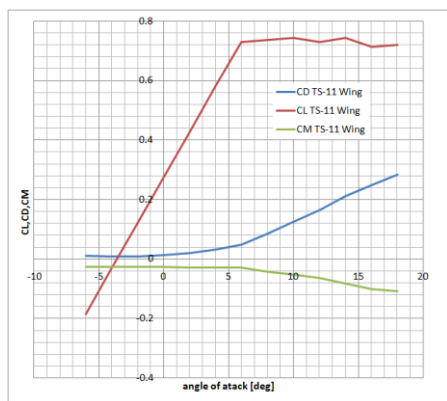

Figure 34 – CFD fluent – results of calculation

REFERENCES

[1] Tadeusz Sołtyk, *Amatorskie projektowanie samolotów*, Biblioteka Naukowa Instytutu Lotnictwa, Warszawa 1999.

- [2] Praca zbiorowa, *TS - 11 Iskra*, Aeromax, Warszawa 2001,
- [3] A. Misiorek, T. Królikiewicz, *Samolot TS - 11 Iskra*, Wydawnictwo Ministerstwa Obrony Narodowej, Warszawa 1971
- [4] Ryszard Kaczmarek, *Budowa i eksploatacja samolotu TS - 11 Iskra*, Wyższa Oficerska Szkoła Lotnicza, Dęblin 1988
- [5] A. Misiorek, T. Królikiewicz, *Samolot szkolno - treningowy TS - 11 Iskra w barwach polskiego lotnictwa wojskowego*, [w:] Wydawnictwo Ministerstwa Obrony Narodowej, Warszawa 1971, str. 8-9
- [6] Tomasz Łaz, *TS - 11 Iskra*, [w:] Praca zbiorowa, Aeromax, Warszawa 2001
- [7] https://pl.wikipedia.org/wiki/PZL_TS-11_Iskra as seen at 19.10.2016

MODELLING FLEXIBLE OPTIONS AT PASSENGER TERMINALS – AN APPLICATION TO LISBON AIRPORT

Liliana Magalhães

CERIS, Instituto Superior Técnico, University of Lisbon

liliana.magalhaes@tecnico.ulisboa.pt

Vasco Reis

CERIS, Instituto Superior Técnico, University of Lisbon

vascoreis@tecnico.ulisboa.pt

Rosário Macário

CERIS, Instituto Superior Técnico, University of Lisbon

rosariomacario@tecnico.ulisboa.pt

Abstract – This article offers an application to a case study of a methodology for the evaluation of flexible options. We use a simulation model to test the benefits of flexible options in terms of performance gains (waiting time). Flexibility has been advocated as something to pursue to increase the airports' resilience and performance. However, no assessment tool to quantify its benefits in terms of passenger processes at terminals was developed so far. Based on our results, flexibility can increase the performance by reducing the waiting times. Consequently, passengers will have more time available to use non-aeronautical services and therefore, become more satisfied.

Key words – Passenger terminals, Flexible airport terminals, airport development, simulation.

INTRODUCTION

For a long period, air transport benefited from a protected and steady growth where airports were essentially public providers of transport infrastructure. Then, a liberalisation wave started with unpredictable demand, growing financial constraints, new social trends or successive technological leaps (Burghouwt, 2007; Vasigh, Fleming, & Tacker, 2008). The new context is dominated by less regulation. Airports are becoming commercially-oriented firms that compete for

a variety of customers and services (Graham, 2010). Business viability is increasingly uncertain.

Planning infrastructures with very long lifecycles is inherently uncertain due to unreliable forecasting techniques (Richard de Neufville & Odoni, 2003). Nowadays, the major challenge in airport planning lies in the need to quickly and economically adapt to the ever-changing context (Magalhães, Reis, & Macário, 2015). An alternative approach based in the principles of flexibility is being advocated (Burghouwt, 2007; Neufville, 2008; Butters, 2010; Magalhães, Reis, & Macário, 2013).

Flexibility is herein defined as the ability to change an infrastructure in time to respond to its capacity needs with maximum value for money of the investment used. It can be applied at three different moments with diverse objectives, namely: extension, which consists in using flexible options to better exploit current airport capacity without the need to change infrastructure's footprint; expansion, consists in increasing the infrastructure's footprint with flexible options, and; reduction, consists in using flexible options to reduce the capacity of the infrastructure's footprint when demand is lower than expected.

Flexibility is studied herein in the context of extension. No research about embedding flexibility at this level has been

found (Magalhães, Reis, & Macário, 2016). Small capacity investments with quick implementation are preferred over high investments which take years to be fully exploited. For instance, instead of expanding a terminal for international arrivals, moveable walls can provide the required additional capacity and delay that investment. Airports with limited capacity of expansion are greatly benefited as they can increase capacity within the footprint. Although the benefits of flexibility have been discussed, no actual assessments or tools have been developed.

The purpose of this study is to validate a novel conceptual methodology that we developed, which provide a detailed road map for the implementation and assessment of flexible options. Flexible options will be assessed in function of the operational performance outputs related with the level of service (e.g. waiting time) using simulation. We will present the results of our simulations for Lisbon Airport Terminal 2. These flexible options are introduced to solve the bottlenecks generated by the capacity changes.

FRAMEWORK FOR THE IMPLEMENTATION OF FLEXIBILITY

Measuring the benefits of flexibility is difficult. Isolating the impact of flexibility in a scenario of contextual change is no easy matter, as there are a large number of factors that impact the performance of airports. However, it is important to assess the benefits of flexibility from a productivity gain point of view.

This study presents a new methodology for evaluating flexibility which intends to support the airport managers' decision upon which flexible option, if any, should be applied. We adopted the vision proposed by other authors (Neufville & Cardin, 2008; Neufville, 2008; Neufville & Scholtes, 2011; Eckart, 2012) that flexibility can be evaluated through the comparison of different scenarios.

According to (Vreeker, Nijkamp, & Welle, 2002), four types of evaluation styles can be distinguished, namely: monetary decision approach, based on cost and benefits (or effectiveness) principles; utility theory approach, based on a multicriteria analysis which is used to rank the decision-makers' preferences; learning approach, which is based on a sequential articulation of the decision-maker's views, and; collective decision approach, which is based on a multi-person negotiation or voting procedures. Based on a series of interviews in airports worldwide, we decided to pursue a monetary decision approach based on a cost-effectiveness analysis, as this seems the preferred type of evaluation for airport managers' decision upon a certain flexible option. We conducted a series of interviews between 2012 and 2014 to airport managers of the following airports (we are using

the IATA codes): LIS, AMS, ZRH, FRA, ATH, BOS, VCP, GRU, GIG and SDU. These interviews were also used to empirically validate our methodology.

This methodology is composed by five distinct phases: two decision moments and three main groups of steps. The **first phase** is a decision moment where airport managers have to decide if they are considering flexibility for capacity extension purposes. This framework was developed for this type of flexibility.

The **second phase** is the setting the scene. This is the phase at which all decision inputs are defined and the scene is set. It has two main parts: the determination of the decision inputs and, the choice of scenarios and flexible options. Concerning the decision inputs, airport managers have to decide the scope of the work and the period of analysis. The scope is related with which parts of the airport will be analysed. Is it the whole terminal? The check-in area? Flexibility can be applied at different levels with different types of options (Magalhães et al., 2013). Therefore, the use of flexibility has to fit the scope as different types of flexible options can be found for each scope. The period of analysis will influence the scenarios which will be used in the study. An analysis for a season generates different scenarios when compared with a 5-year period. Thus, it is necessary to define with precision the analysis period. The decision variables are chosen by the airport manager. The reason to let the airport manager choose the decisions variables is that flexibility has been linked with costs savings, time reductions and increase of performance (or robustness towards change) as explained above. But there is no common understanding of what variables should be used to analyse it (Magalhães et al., 2015). So, by letting the airport manager choose the decision variables this methodology fits each specific airport. However, the decision variables have to reflect the processes at the terminal for passengers and luggage. The objective of this methodology is to analyse the benefits of flexibility for extension. Thus, the variables have to reflect what is going on inside the terminal in terms of capacity, productivity and costs of the processes. The scenarios and flexible options choice is where all the main sources of uncertainty shall be identified and the possible future scenarios defined. As explained above, air transport is a highly dynamic business with several sources of uncertainty. These uncertainties leave airports in a difficult position to respond to change quickly. For each scenario, the suitable flexible options to deal with it shall be identified to be evaluated in the next phase, according to the scope of the study. If possible, each scenario should have an associated probability of occurrence. This information will be helpful for the airport manager in the next phase. If there is a

scenario with a high probability of occurrence when compared with the others, airport managers might choose the flexible option with the best results for this scenario instead of one with good results for all scenarios. As mentioned above, flexible options can be diverse (e.g. from moveable walls to modular terminals). As different scenarios require different flexible options, it is important to evaluate (in the next phase) the results obtained for each alternative for each scenario, in order to choose the one which produces the best results. Yet, to achieve this, is important to list the uncertainties, to develop the scenarios and list the flexible options to respond to them.

The **third phase** is the ex-ante operational evaluation. At this phase, flexible options will be evaluated for each scenario in order to understand if they provide better results than the “do nothing” option, which means to leave things as they are. This phase requires information from the previous one. The values of the decisions variables for the base case, which corresponds to the current situation, are estimated as well as for each flexible option for each scenario. Regarding the evaluation method, it has to be chosen based on the analysis period and the scope itself. Long-term analyses are typically based on pre-investment analysis whereas short-term analyses, related with airport daily operations, are usually analysed with microsimulation methods. Therefore, the aspects defined in the previous phase will influence the type of analysis performed. Moreover, it has to be taken into consideration if it is possible to associate a probability of occurrence to each scenario or not. Some evaluation methods are not able to incorporate probabilities. This phase serves the purpose of understanding if flexibility is an option to extend the capacity and delaying expansion. Thus, at the end of this phase if flexible options do not provide better results than “do nothing” (base case), the analysis should stop. This means that flexibility is not the answer to the problem. If it is not the case, we should proceed to the next phase. This evaluation is based on decision variables that are chosen by the airport manager. To decide whether or not to proceed for flexible options, a matrix that compiles the obtained results for the decision variables for the base case and all the alternative flexible options for each scenario can be used. Figure 1 presents a generic matrix that provides an example for two different scenarios and n decision variables. Whenever the differences between the results obtained for the flexible options and the base case are positive (green), it is clear that flexible options will provide better results for that specific scenario.

The **fourth phase** is another decision moment. Once the previous phase is finished, it is time to look at the results and

forwent all the flexible options that, for each scenario, produce worse results than the base case (current situation).

The **fifth phase** is the ex-ante value for money evaluation. This is the phase at which the capacity extension portfolio of flexible options is produced. Once airport managers decide to proceed for flexible options, it is time to observe which flexible option provides more value for money, using a cost-effectiveness analysis. This methodology does not say to airport managers which option should be chosen. It only evaluates the results obtained for each flexible option for each scenario, pointing out the flexible options that provide the best results in each scenario. This evaluation is based on the probability of occurrence of each scenario, if available, and the value for money that takes into account the cost of the flexible options and productivity results that are captured by the decision variables.

MODELLING FLEXIBLE OPTIONS AT LISBON TERMINAL 2

In this study we apply the methodology to Terminal 2 at Lisbon International Airport. We seek a more robust validation through simulation. We are developing a hybrid simulation model based in discrete event (to simulate the processes) and agent based (to simulate passengers and staff behavior). Discrete-events have been advocated as a proper way to reproduce airport processes (Neufville & Odoni, 2003). Therefore, as we are linking flexible options with the airport processes, discrete event seems to be the better tool to use. We are considering all the processes for departures. Notwithstanding, we also want to capture the behaviour of the passengers and staff involved in the processes. Moreover, as some processes depend on human resources (e.g.: traditional check-in), human flaws (e.g.: fatigue, lack of attention) are important to capture in our model since they will influence the overall performance. However, due to data limitations to date of submission of this article we stopped out methodology at phase 4.

	Decision Variables	BASE CASE FOR SCENARIO X				BASE CASE FOR SCENARIO Y			
		DV ₁	DV ₂	...	DV _n	DV ₁	DV ₂	...	DV _n
SCENARIO X	Flexible Option A	DV ₁	Δ+			Δ+			
		DV ₂		Δ+			Δ+		
		...			Δ+			Δ+	
		DV _n				Δ+			Δ+
SCENARIO X	Flexible Option B	DV ₁	Δ+			Δ-			
		DV ₂		Δ+			Δ-		
		...			Δ+			Δ-	
		DV _n				Δ+			Δ-
SCENARIO Y	Flexible Option B	DV ₁	Δ-			Δ+			
		DV ₂		Δ-			Δ+		
		...			Δ-			Δ+	
		DV _n				Δ-			Δ+
SCENARIO Y	Flexible Option C	DV ₁	Δ+			Δ-			
		DV ₂		Δ+			Δ-		
		...			Δ+			Δ-	
		DV _n				Δ+			Δ-

Figure 31 - Matrix to support the analysis of the results obtained at the ex-ante operational evaluation phase

We are using the AnyLogic software to develop this hybrid simulation model. The model is organised in three layers: the physical, refers to the actual infrastructure's footprint (terminal); the logical, refers to the actions of the passengers, and; the resources, which refers to the existent equipment, staff and others. The discrete event approach models the processes whereas the agent based approach will model passengers and resources' behaviour, which are limited by the infrastructure while running through the process. Our inputs are related with processes and staff performance (e.g. queue length, counters' capacity per unit of time, passengers' arrival flows, waiting times), as well as passengers information (e.g. percentage of business versus touristic, percentage of international versus domestic). The input information is used in the simulator to test the response of several flexible options at different scenarios, in order to assess the operational gains. The outputs of the model will be focused on processes' performance for the flexible options. This outputs will then be used to assess the best flexible option to respond to each tested scenario.

The reasons to develop this simulation for Lisbon Airport Terminal 2 are several. Lisbon Airport cannot be expanded beyond its current limits. The building of a new airport is not being considered due to the current economic Portuguese situation. Notwithstanding, the traffic has been growing rapidly especially with the recent starting of operation of Ryanair. So, there is a need to accommodate demand without compromising the quality of service and also, by avoiding expansion. Thus, Lisbon Airport a perfect case study for the extension scope.

As we are under the scope of an extension case, we can proceed to the second phase of our methodology. The scope

of our study is the departure process. This terminal only conducts departures. We will analyse the bottlenecks and applied flexibility in the aeronautical activities (check-in and border control) which present capacity issues. The period of analysis is a standard operation day (October 26th, 2016). During this day, Terminal 2 had 41 flights of four airline companies, namely: EasyJet, Ryanair, Transavia and Wizzair. The STD of the flights ranged from 5.15 am to 21.20 pm. This information as well as the information concerning the check-in counters and boarding gates was gently provided by ANA – Aeroportos de Portugal, for the purpose of this study. For the purpose of this study we will only use a decision variable – waiting time. This variable is one of the most used to assess the level of service (IATA, 2004). The scenario for our simulation is actually the current situation – add a new airline to the terminal. Our goal is to see if flexible options will help to increase the capacity now that Ryanair arrived to Lisbon Airport. No probability of occurrence will be used. As this is the current situation, no probability of occurrence will be needed. The flexible options that we will use to deal with the capacity issues for each aeronautical activity are in Table 1.

The evaluation method will be based in the assessment of the waiting times during the simulation for each aeronautical activity. We will assess the waiting times for the current situation (base case) and for the situation with flexible options. Then, we will determine the differences between these values for the base case and the flexible options. As we are only considering one scenario and one decision variable, there is no need to build up a complex matrix as the one in Figure 1.

Table 16 - Flexible options used in the simulation

Aeronautical activity	Flexible option	Condition
Check-in	Open new check-in counter	When waiting time exceeds 20 minutes
Border control	Open new check-in counter	When there is a Non-Schengen flight

SIMULATION OUTPUTS

The simulation model was calibrated based on observations as well as the information provided by the airport manager. Figure 2 presents the parameters that we needed to calibrate. The other parameters (e.g. arrival times at the airport, percentage of luggage, percentage of online check-in, etc.) were provided by the airport manager.

The percentages of passengers conducting online check-in and traditional check-in are 40% and 60%, respectively, except for Ryanair in which case is the opposite. Both Transavia and Wizzair have two check-in counters at the terminal. EasyJet has six and Ryanair four.

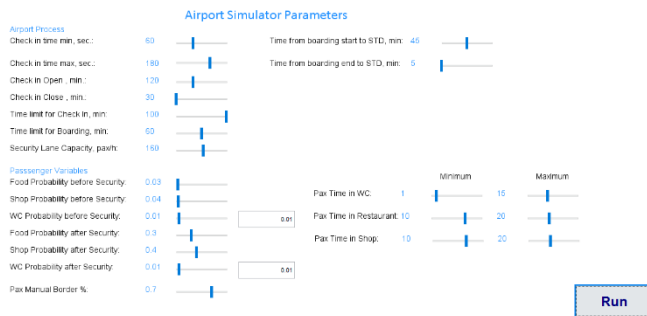

Figure 32 – Calibrated parameters

In the current situation, Terminal 2 presents capacity issues at check-in and border control. The maximum waiting time in the check-in queue currently reaches 50 minutes. On the manual border control, the maximum waiting time can easily reach 25 minutes. Some passengers reach this point without this amount of time to spend here. On the other hand, the ones who reach this point earlier represent less money spent on non-aeronautical activities as beyond this point, there are no shops or restaurants. Figure 3 presents the queue at border control in the simulation for the current situation.

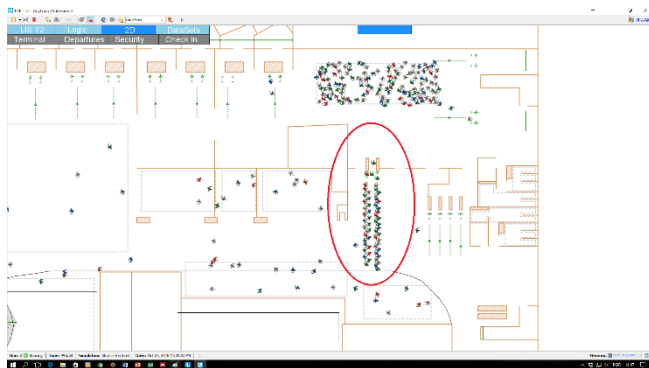

Figure 33 - Queue at border control for the current situation

In order to solve this issues, we introduced the flexible options in Table 1.

Check-in

A check-in counter is being opened, immediately next to the ones in operation, when waiting time for the passengers of one airline exceeds 20 minutes.

This flexible options represents a major increase in the performance of EasyJet and Ryanair operations. For both airlines, a new check-in counter is open. For Transavia and Wizzair there is or need for a new check-in counter, the waiting times are lower.

The maximum waiting time is now 25 minutes. This is a huge improvement when compared with the current situation.

Border control

For the border control, as the processing time of the border staff is not good enough, we decided to have three counter opened whenever there is a Non-Schengen flight.

With the introduction of a new border control position, the maximum waiting time decreases to 10 minutes.

This time saving means that passengers can spend more time at the airport doing non-aeronautical activities and consequently, spending more money. Moreover, there is a satisfaction for the passenger which may lead him/her to choose this airport instead of another.

To fully apply our methodology it was now time to estimate the costs of having both flexible options working and present them to the airport manager. However, due to the lack of data by the time we submitted this article this was no possible. Nevertheless, it is clear that flexible options helped to increase the performance in terms of waiting time and consequently, level of service.

CONCLUSION

The traditional airport development approach based on master plans, proved to be limited when it comes to cope with uncertainty. Air transport is a highly dynamic business that requires flexibility. This is a solution, for instance, to increase the capacity of the airport to respond to external changes.

So far, flexible options have been used ad hoc without any robust or systematic approach to quantify their benefits. The implementation of flexibility in airports has been dispersed and mostly based on airport managers’ skills. Some frameworks have been presented but without the possibility of quantifying the benefits and the costs of flexibility. However, it is important to evaluate this trade-off between the gains and the costs. From an airport manager’s point of view, the pursuit of flexibility is highly dependent on this trade-of.

We conducted a series of interviews to ten airports worldwide to empirically validate this methodology.

It is organised in five distinct phases: two decision moments and three main groups of steps. The first phase corresponds to a decision moment, where airport managers have to decide if they are considering flexibility for capacity extension purposes.

Flexible options proved to increase the performance for the decision variable that we chose (waiting time).

This was a simple application of our methodology to a case study. As we only consider one scenario and one decision variables (waiting time), no complex matrix is necessary. More decision variables have to be added. Moreover, due to the lack of information by the time we submit this article, it was not possible to proceed to the last phase of our methodology. This should be the next step.

This methodology provides an organised approach for the evaluation of flexibility and by doing so, it contributes to increase the knowledge on airport flexibility. We are contributing to fill a major gap of knowledge in the current literature on this topic. Moreover, the general nature of some of the steps allows the application of this framework in other contexts.

ACKNOWLEDGMENTS

This research was supported by the Portuguese Foundation for Science and Technology (FCT) under Grant [SFRH / BD / 52361 / 2013].

We also would like to acknowledge our colleague Duarte Amorim da Cunha for all the support with the simulation software.

REFERENCES

[1] Burghouwt, G. (2007). *Airline network development in Europe and its implications for airport planning*. Hampshire: Ashgate.

[2] Butters, M. (2010). Flexible airport design. *Airport Management*, 4(4), 321–328.

[3] Eckart, J. (2012). *Flexible urban Drainage Systems in New Land-use Areas*. University of South Florida.

[4] Graham, A. (2010). Airport Strategies to Gain Competitive Advantage. In P. Forsyth, D. Gillen, J.

Müller, & H.-M. Niemeier (Eds.), *Airport Competition – The European Experience*. Ashgate.

[5] IATA, I. A. T. A.-. (2004). *Airport Development Reference Manual* (9th ed.). Montreal, Geneva: International Air Transport Association.

[6] Magalhães, L., Reis, V., & Macário, R. (2013). Airport Flexibility : a First Glimpse on the external factors. 13th WCTR Conference. Rio de Janeiro, Brazil.

[7] Magalhães, L., Reis, V., & Macário, R. (2015). Can flexibility make the difference to an airport's productivity? An assessment using cluster analysis. *Journal of Air Transport Management*, 47.

[8] Magalhães, L., Reis, V., & Macário, R. (2016). A literature review of flexible development of airport terminals. *Transport Reviews*, 1–18. Routledge. Retrieved October 27, 2016, from <https://www.tandfonline.com/doi/full/10.1080/01441647.2016.1246488>

[9] Neufville, R. de. (2008). Low-Cost Airports for Low-Cost Airlines: Flexible Design to Manage the Risks. *Transportation Planning and Technology*, 31(1), 35–68. Retrieved December 12, 2013, from <http://www.tandfonline.com/doi/abs/10.1080/03081060701835688>

[10] de Neufville, R., & Cardin, M.-A. (2008). *A Survey State-of-the-art Methodologies and a Framework for Identifying and Valuing Flexible Design Opportunities in Engineering Systems*. Cambridge, Massachusetts.

[11] Neufville, R. de, & Odoni, A. (2003). *Airport Systems: Planning, Design and Management*. New York: The McGraw-Hill Companies.

[12] Neufville, R. de, & Scholtes, S. (2011). *Flexibility in Engineering Design*. Cambridge, Massachusetts: MIT Press.

[13] Vasigh, B., Fleming, K., & Tacker, T. (2008). *Introduction to Air Transport Economics*. Ashgate.

[14] Vreeker, R., Nijkamp, P., & Welle, C. Ter. (2002). A multicriteria decision support methodology for evaluating airport expansion plans. *Transportation Research Part D*, 7, 27–47.

EMPOWERING YOUR EMPLOYEES TO A BETTER FATIGUE MANAGEMENT IN HIGH RISK INDUSTRY.

Karina Mesarsova, MSc.

KM Flight Research and Training, Egypt

University of Žilina, Slovakia

km@flightresearch.eu

Abstract – Pilot fatigue has been making aviation headlines in the past years as we are regularly reminded about this reality of aviation by articles quoting the crew falling asleep at the controls and it is time to act. The general aviation pilots are subject to the same fatigue-related risks and potential for disaster as we operate on a 24-hour basis and require high levels of alertness from our operatives, the reality of fatigue is inevitable and it's up to us to manage it. The division of responsibilities for fatigue management is that of a shared responsibility between the State, the operator, and the individual crewmember. The State shall provide the necessary regulatory framework and ensure that it provides the necessary regulatory oversight to ensure that the State operators manage their fatigue risks to an acceptable level (ICAO, 2013, sec. 4.10). The operator must ensure that work schedules allow crews to operate safely, make use of processes for monitoring and managing fatigue hazards and provide suitable fatigue management education (ICAO, 2016, p. 38). Finally, the individual crewmember is responsible to ensure that they are fit for duty, this includes that they make best use of non-work periods to obtain sleep, managing their own fatigue levels and for reporting any fatigue hazards (ICAO, 2016, p. 39). While the first responsibilities of the State and operator are straight forward the final responsibility of an individual is far more complex as we do not have the objective measures that allows the individual to clearly demonstrate their unsuitability to operate a flight. How this gap can be addressed will be discussed in this presentation.

Key words – fatigue, fatigue risk management, individual responsibility

INTRODUCTION

With the aviation traffic in Europe predicted to reach 14.4 million flights in 2035, which is a 50% increase in comparison to 2012 (EASA, 2016), our primary objective is to make sure that the aviation “system” continues to maintain the current low number of accidents. It is reasonable to expect that the aviation system can at least maintain the current accident rate (Fig.1).

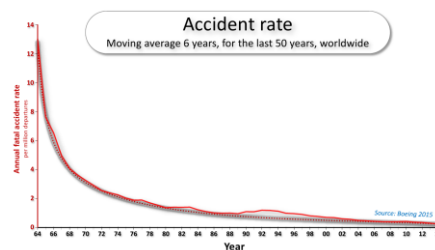

Figure 1- Annual fatal accident rate, per million departures (Boeing, 2015).

Based on that, if we do nothing to improve the system and with the increase of the traffic, it would mean that the number of fatalities would increase by around 30% due to the expected increase in traffic (Fig.2).

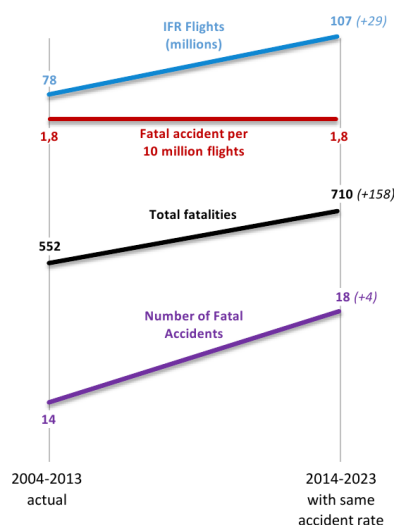

Figure 2- Aviation Safety Trends in EU (EU Commission staff working document SWD(2015) 262 final).

The research interest in fatigue has increased with the growth of accidents attributed to human error, despite an overall reduction in accidents, the UK Civil Aviation Authority (UK CAA CAP 720) research claims that 65% of accidents in air transportation are due to flight crew errors, many are traced back to a decrease in performance due to deprivation of sleep.

The unsociable working hours and continuous twenty-four-hour operation schedules result in a disruption of the circadian rhythm and cumulative sleep loss (Rosekind et al, 1997) that result in fatigue with a negative impact on performance.

There are three distinctive influences on fatigue, identified from the psychological point of view; the task induced fatigue, sleep deprivation and time of day (disruption to circadian rhythms) (Matthews et al, 2004). Performance in general is affected by the time of day that the task is performed (Green et al, 2005); simple tasks such as reaction times, visual search speeds and vigilance, require low working memory, improve during the morning to early afternoon hours and decline in the evening, reaching the lowest levels of performance at 4 am in the morning. (Green et al, 2005). Individuals tend to show differences in their preferred time of day, some are so called “owls” (evening types), some are “larks” (morning types) (Matthews et al, 2004), the subjective arousal of an evening type is higher in the evening and for morning type it is in the morning. This is reflected in their performance; however, this effect seems to vary with the tasks and associated processing demands (Natale & Lorenzetti, 1997 as cited in Matthews et al, 2004). One of the many examples of time of day fatigue is a BAC 1-11 incident (1990), “where incorrect bolts were fitted in the captain’s windshield, the engineer fitted the windshield between 0300 and 0500h probably during the lowest phase of his circadian efficiency” (Green et al, 2005). Prolonged mental activity can markedly impair some aspects of performance; e.g. the longer the flight duration the higher the fatigue ratings (Samel et al, 1997 as cited in Eriksen & Akerstedt, 2006).

Night duties are especially fatigue prone, as they often combine circadian disruption with prolonged duty leading to psychomotor impairment and reducing the ability to respond to changing circumstances (Akerstedt et al, 2003).

Vigilance studies have shown that with certain tasks maintaining constant levels of performance is difficult, however not every task is sensitive or inductive to fatigue (Stokes & Kite, 1994). One major factor in task related fatigue seems to be the monotony of the task (Williamson et al 2001 as cited in Richter et al, 2005), Holding (1983) suggested that some highly skilled and complex tasks are

highly unlikely to lead to performance deteriorations (as cited in Mathews et al, 2004), where we can conclude that cognitive demanding tasks tend to be more interesting and therefore induce the effect of increased arousal (Richter et al, 2005).

The Circadian rhythm, or circadian clock, controls the timing of physiological activity (thermoregulation, digestion, immune function) (Rosekind et al, 1996) and performance, alertness and mood.

The lowest activity point of the circadian clock for human functioning is circa 3am to 5am, the second low point occurs at circa 3pm to 5pm and this is also associated with decreased performance (Graw, Kräuchi, Knoblauch, Wirz-Justice, & Cajochen, 2004; Wirz-Justice, 2007).

Finally, sleep deficiency or sleep loss is recognized as a major cause of industrial accidents (Smith & Kushida, 2000 as cited in Swan et al, 2006) and the key factor contributing to fatigue (Dinges et al, 1994), the sleep requirement for an adult is in the range 7 to 8 ½ hours (Van Dongen et al, 2003 as cited in Swan 2006, Akerstedt et al, 2003), but the average that a person obtains today is somewhere between 6 to 7 ½ hours (e.g. Kripke et al, 2003, as cited in Swan, 2006, Rosekind et al, 1997), this would suggest that most of the population may be chronically sleep deprived. However, a sleep loss of circa 1 to 2 hours does not have a significant effect on fatigue or performance, but greater than 2 hours’ loss is linked to reduced performance. Sleep loss is accumulative, and this is often seen in the case with shift work, early rising, night work or time zone shifts; further a reduction of sleep to only 5 hours per day for 5 days, is the equivalent for fatigue and performance to the loss of one full night’s sleep (Akerstedt et al 2003). Reduction in sleep time is especially likely when sleep is taken during the day, where many environmental factors (e.g. stress, noise, sleeping position) contributing to the disturbance of both quality and quantity of sleep (Akerstedt et al., 2003).

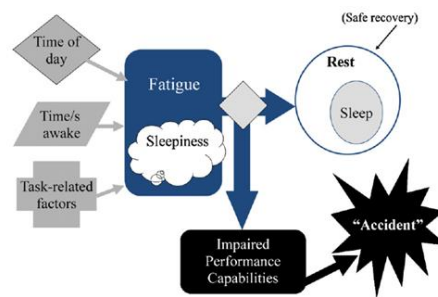

Figure 3- Factors in the Relationship Between Fatigue and Safety (A. Williamson et al., 2011, p. 499).

Aircrew as a normal part of their occupation face the challenges of crossing and sleeping in different time zones, this is recognised to have important role in aviation and fatigue related accidents, and is referred to as the ‘acclimatisation’ of the crew. The UK CAA CAP 371 defines this as “When a crew member has spent 3 consecutive local nights on the ground within a time zone which is 2 hours wide, and is able to take uninterrupted nights sleep. The crew member will remain acclimatised thereafter until a duty period finishes at a place where local time differs by more than 2 hours from that at the point of departure”.

Reporting time for duty is also a factor in the onset of fatigue, particularly early starts or finishes of duty are considered and lead to increased risk for fatigue (UK CAA CAP 371). Further the cumulative effects must be considered, no more than three consecutive flights that start or finish within the period of 0100 to 0659hrs local time could be operated by crew under the UK CAA FTLs scheme.

On one side, we have a fatigue as a complex issue on the other the identification of these potential hazards and how to regulate them (Fig.3).

THE TRIAD OF OVERSIGHT

The fatigue management falls under a triad of oversight, the National Aviation Authority, the Operator and the Individual; each responsible for managing fatigue with the tools available to them, to manage fatigue and any associate hazards. The State is to provide the necessary regulatory framework and ensure that it provides the necessary regulatory oversight to ensure that the State operators manage their fatigue risks to an acceptable level (ICAO, 2013, sec. 4.10). Further, the operator must ensure that work schedules allow crews to operate safely, make use of processes for monitoring and managing fatigue hazards and provide suitable fatigue management education (ICAO, 2016, p. 38). Finally, the individual crewmember is responsible to ensure that they are fit for duty, this includes that they make best use of non-work periods to obtain sleep, managing their own fatigue levels and for reporting any fatigue hazards (ICAO, 2016, p. 39).

INDIVIDUAL RESPONSIBILITY – THE PITFALL

While the regulation is clear on the individual responsibility, how exactly this should be achieved is still an elusive science as it is relying on purely subjective assessment of the individual himself. While one would agree that there are major differences in perception and indeed in state of fatigue on individual level. The lack of clear methodology gives a space for misinterpretation i.e. when there is a crew shortage,

fatigue argument is more likely to be overlooked and participation for reward more likely offered. An approach not compatible with a proactive safety culture.

READYMADE TOOLS

In dynamic environment, we need equally flexible monitoring devices that can be customized to the individual. Currently there are tools on the market, that are used for tracking exercise and sleep pattern called activity trackers. The science behind them has evolved over the past years with an additive of heart rate monitor to increase accuracy. It is a low-cost tool that has a potential to be used in monitoring of one sleep, one of the factor in fatigue management. Activity trackers, so called wearable technology, is a device for monitoring fitness metrics, these can be a combination of number of metrics such as distance walked, stairs took, calorie consumed, heartbeat count and quality of sleep. It is an electronic monitoring device that is synced, mostly wirelessly, to a computer or a smartphone for long-term data collection.

FUTURE EASA PERFORMANCE BASED ENVIROMENT

Performance-based regulation and oversight is a regulatory and oversight approach that focuses on measurable safety outcomes, rather than purely mechanic compliance with prescriptive limits. The tools used must be also tailored to the individual, and with the realization that crew fatigue levels are highly individual, an individual norm has to be established.

New Subpart FTL applied in February 2016 sets the legal requirements for the approval of Fatigue Risk Management (FRM), where operator is responsible for actively managing fatigue risk, and one of the mandatory controls that must be put in place is fatigue management training (ORO.FTL.250). A combination of such awareness program in combination with an objective measure such as the tracking device seems a positive step ahead however, how accurate are these devices in predicting the real sleep time and quality?

In laboratory to measure sleep and sleep disturbances we would use a Polysomnography or in an active environment an actigraph. Actigraphy is a small wristwatch like device, using an accelerometer to record movements over long periods of time, typically seven days. The raw data is passed through a computer based algorithm to generate sleep-wake data (Sadeh, 2011). This is however researcher friendly but not user friendly.

From a research point of view, if we want to achieve an awareness of sleep metrics and from that derive more

objective fatigue levels, we need to concentrate on sleep. The essential component and indicator of fatigue in healthy individuals is sleep, however, currently a state of art of sleep monitors are neither easy to use for an active individuals and are mostly used in research in individuals with sleep problems. As our aim is to find a low cost option to increase fatigue awareness of individual level of fatigue, our goal is to use a simple method that induces the individual to monitor themselves and to continue to do so in long term. Laboratory based monitors do provide a great deal of data that allow to indicate a sleep problem, in healthy individual we want to achieve a simple sleep indicator, as per previous research in sleep the most important indicators for accessing sleep are: Total Sleep Time (TST) Sleep onset latency (SOL) and Sleep efficiency (SE).

A trial Fatigue Risk Management (FRM) training (a group of 8 participants, airlines employees) in a combination with a trial of wearing an active watch (commercially available Fitbit HR) by the attendees during the period of training' where participants were asked to monitor their activity and sleep pattern, yielded positive results, with participants gaining a better awareness of their fatigue levels. This combination of awareness training and practical demonstration of monitoring gives the individual the tools to be actively managing their one sleep pattern and therefore more capability in reducing fatigue. Initially, 6 out of 8 participants were not aware of their sleep duration and were vague about the perceived of their quality. After wearing the active watch the participants showed more enthusiasm and ability to describe the sleep pattern and length. It had a positive impact on their perception of the usefulness of the training as the measurements of sleep and “*realness of the problem*” and “*not just a classroom exercise*”. Ultimately with such encouragement, our aim is to offer potential solution to the challenge of individual fatigue monitoring for HRI and open avenues for further research by finding an accurate objective measurement of objective sleep.

METHOD AND RESULTS

We undertook the evaluation of MEMS (microelectromechanical systems) tri-axial accelerometer based actigraphy and consumer based tri-axial activity monitoring device for use within the FRM in high risk industries offers a low-cost option to monitor sleep quality and length.

Every participant (N=16) wore the Fitbit HR and MW8 for 7 days and filled in a sleep diary every day during their 7-day participation in the research, as well as demographics

questionnaire and chronotype questionnaire. The data was downloaded immediately after it was received The data was analysed using statistical analysis using the proprietary software IBM® SPSS.

The variables for each sleep episode was compared (duration, efficiency, and latency) using Pearson’s correlation coefficients and paired t-tests. To assess the extent of agreement, the intra-class correlation coefficient (ICC) and concordance correlation were calculated (Table, 1,2,3).

	mwtst1	mwtst2	mwtst3	mwtst4	mwtst5	mwtst6	mwtst7
fittst1	0.361						
fittst2		.668*					
fittst3			.855**				
fittst4				.584*			
fittst5					.829**		
fittst6						0.453	
fittst7							.715**

Note : Correlations marked with an asterisk (*) were significant at $p < .05$ (2-tailed). Correlations marked with an asterisk (**) were significant at $p < .01$ (2-tailed).

Table 1 Bivariate correlations between Fitbit HR TST and MotionWatch8 TST

	mwsol1	mwsol2	mwsol3	mwsol4	mwsol5	mwsol6	mwsol7
fitsol1							
fitsol2		-0.119					
fitsol3			-0.089				
fitsol4				-0.218			
fitsol5					-0.038		
fitsol6						-0.234	
fitsol7							

Table 2 Bivariate correlations between Fitbit HR SOL and MotionWatch8 SOL

	mwse1	mwse2	mwse3	mwse4	mwse5	mwse6	mwse7
fitse1	-0.248						
fitse2		-.815**					
fitse3			0.211				
fitse4				0.522			
fitse5					-0.329		
fitse6						0.371	
fitse7							0.101

Note : Correlations marked with an asterisk (**) were significant at $p < .01$ (2-tailed)

Table 3 Bivariate correlations between Fitbit HR SE and MotionWatch8 SE

Descriptive analyses were conducted to examine associations with the criterion measure. Pearson correlations were computed to examine overall group-level associations. Comparison of sleep parameters values: Total Sleep Time (TST), Sleep Latency (SL), Sleep efficiency (SE), obtained by a tracking device Fitbit and actigraphy (ACT) MotionWatch (MW8, CamNtech Ltd.)

The strongest relationship between the tracking device Fitbit and actigraphy were seen for the TST, the Fitbit monitors were highly correlated with actigraphy watch, the correlation coefficients ranged from $r = 0.453$ to 0.855 over the 7-day period. Except the first day where there was no significance recorded. There seem to be no significant correlation between the tracking device Fitbit and actigraphy for the SE, except on the day two, where only negative correlation was recorded.

SUMMARY

Each State regulator has the immense responsibility to ensure sufficient protection from fatigue risk for all crewmembers, based on scientific knowledge and principles. The science of fatigue is continually developing and at present does not have all the answers, due to the complex nature of fatigue and the difficulty of extending laboratory highly controlled experimentation into the dynamic field conditions of aviation. Individual differences in the homeostatic and circadian processes add to the complexity (Van Dongen, Bender & Dinges 2012), combined with the social (family, young child etc.) and operational (roster pattern, noise, poor hotel, crew rest facilities etc.) phenomena that alter individual sleep-wake behaviour. Fatigue research is advancing, with a move away from the psychometric performance measures, towards approaches that capture the real dynamics of the environment, that will aid the performance based approach of FRMS (Dawson 2012; Gander et al. 2011).

From the first part of our study, we can conclude some benefits of the tracking device in perception of the usability within the training, however in comparison to the sleep device tracking activity monitor correlate significantly only on the TST. This does offer the individual an important indicator about their basic sleep status and an objective data.

This allows the regulator to gain benefits beyond the prescriptive limits of a FTL scheme, through the added requirements of education and training in fatigue (including senior management), continuous monitoring of fatigue levels, and the systematic analysis of flight data monitoring events for fatigue related factors. Predictive biomathematical modelling is also advancing with increase input from operational studies, adding the complexity of workload and increased risk exposure (e.g. approach and landing) and with the addition of the potential for individual data input (chronotype). A combination that will give the regulator deeper insight into fatigue factors and allow for better decisions as to punitive action against organisations

who fail in their duty of care. Performance based regulation is built upon greater support and education, this partnership approach of the regulator working with industry to demonstrably reduce safety risk, is the way forward for fatigue management. Combined with suitable punitive measures to eliminate pressure from the operator on crewmembers to avoid fatigue reports.

REFERENCES

- [1] Åkerstedt, T. (2007). Altered sleep/wake patterns and mental performance. *Physiology & behavior*, 90(2), 209–218. Elsevier.
- [2] CAP 720 (2002) Flight Crew training Cockpit Resource: Management and Line orientated flight training. Retrieved from World Wide Web February 12, 2007
[http://www.caa.co.uk/docs/109/CAP720%20\(digest%202-20CRM%20and%20LOFT\).pdf](http://www.caa.co.uk/docs/109/CAP720%20(digest%202-20CRM%20and%20LOFT).pdf)
- [3] Dawson, D. (2012). Fatigue research in 2011: From the bench to practice. *Accident Analysis & Prevention*, 45, 1–5. Elsevier.
- [4] Dinges, D. F. (2004). Critical research issues in development of biomathematical models of fatigue and performance. *Aviation, space, and environmental medicine*, 75(Supplement 1), A181–A191. Aerospace Medical Association.
- [5] Dinges, D. F. & Powell, J. W. (1985). Microcomputer analyses of performance on a portable, simple visual RT task during sustained operations. *Behavior research methods, instruments, & computers*, 17(6), 652–655. Springer.
- [6] Eriksen C.A., Åkerstedt T. (2006) Aircrew fatigue in trans-Atlantic morning and evening flights. *Chronobiology International*, 23(4):843-858
- [7] Gander, P. (2011). Fatigue Risk Management: Organizational factors at the regulatory and industry/company level. *Accident Analysis and Prevention*, 573-590.
- [8] Green R.G., Muir H., James M., Grawell D., Green R.L. (2005) *Human Factors for pilots*. (second edition) Ashgate Publishing Limited
- [9] ICAO. (2013). Annex 6 to the Convention on International Civil Aviation: Operation of Aircraft. Part I International Commercial Air Transport — Aeroplanes.
- [10] ICAO. (2016). Doc 9966: Manual for the Oversight of Fatigue Management Approaches (2nd ed.). ICAO, Montreal.

- [11] ICAO, 2013, "Operation of Aircraft" (PDF). International Standards and Recommended Practices. February 25, 2013.
- [12] Matthews, G., Davies, D. R., & Westerman S.J., S. R. (2004). *Human Performance Cognition, stress and individual differences*. New York: Psychology Press Hove.
- [13] Rosekind M.R., Neri D.F., Dinges D.F. (1997) *Fatigue and duty Time Limitations – An International Review*, NASA Ames Research Center, United States Navy Medical Service Corps, University of Pennsylvania School of Medicine
- [14] Richter S., Marsalek K., Glatz C., Gundel A. (2005) Task-dependent differences in subjective fatigue scores. *J. Sleep Res.*, 14, 393-400
- [15] Sadeh, A. (2011). The role and validity of actigraphy in sleep medicine: An update. *Sleep Medicine Review*, 15, 259-267.
- [16] Samel A., Wegman H., M., VeJVoda M. (1997) Air crew fatigue in Long-haul operation, *Accid. Anal and Prev.*, Vol.29.No.4, pp.439-452
- [17] Swan C.E., Yelland G.W., Redman J.R., Rajaratman S.M.W. (2006) Chronic partial sleep loss increases the facilitatory role of masked prime in word recognition task. *J. Sleep Res.*, 15, 23-29

RESEARCH AND EDUCATIONAL LABORATORIES OF AIR TRANSPORT DEPARTMENT AT THE UNIVERSITY OF ŽILINA

prof. Ing. Andrej Novák, PhD.

University of Žilina, Slovakia
Andrej.Novak@fpedas.uniza.sk

Ing. Nikolas Žáčik

University of Žilina, Slovakia
Nikolas.Zacik@fpedas.uniza.sk

Abstract. *This paper describes the laboratories of University of Žilina especially flying laboratories established at Air Transport Department in cooperation with Flight Training Organisation-Approved training organisation SK.ATO.01 – Flight School of the University of Žilina). These laboratories are focused on the specific measurement in the airspace for example - environmental, meteorological and electromagnetic field.*

Key words – Flight laboratories, Aircraft, Flight Inspection, Environmental Laboratories, Airborne Sensor

INTRODUCTION

The Air Transport Department and Flight training educational centre of the University of Žilina have many years of experiences with resolving of scientific and research projects in the field of air traffic and general aviation. International and national projects of the University are focused on quality and effectivity management of flight training for pilots. The main effort is given to research and implementation of new technologies and procedures, aviation meteorology, human factor, increasing of safety and quality in civil aviation, economy of aviation industry, airports as well as air traffic control. Four important projects were successfully solved within all of above mentioned fields by University of Žilina. All of those projects were focused on design and building up of required infrastructure in cooperation with the corresponding industry.

The List of projects of the University:

- „Centre of Excellence for Air Transport ITMS 26220120065“
- „Broker centre of air transport for transfer of technology and knowledge into transport and transport infrastructure ITMS 26220220156“

- Implementation of scientific and researching knowledge into air traffic industry, ITMS: 26220220010

- Research of virtual reality application for the purpose sufficient improvement of aviation simulator behaviour ITMS: 26220220167

The outcome of all above mentioned projects was an improvement of whole scientific infrastructure at the University, creation of new labs as well as important connection and future cooperation with real aviation industry. New organisation structures were established as part of outcome of University projects at the University of Žilina. One of those organisations is also Centre of Excellence for Air Transport or Broker centre of air transport for transfer of technology and knowledge into transport and transport infrastructure, within separated labs where established for future research and development of aviation industry.

LABS OF CENTRE OF EXCELLENCE FOR AIR TRANSPORT

AEROLAB 1

The aeronautical laboratory AeroLab 1 is oriented to research in the field of area verification of aviation safety, systems and equipment for the purpose of safety improvements in air traffic department. The research realized in this laboratory is based on measurements of ground aviation safety systems and equipment and their evaluation of their integrity, accessibility, continuity and accuracy of all systems. Analysis of chosen communicative and navigation surveillance systems in frequency band KV and VKV is also possible. These systems can be for example: radiolocation systems VOR, DME ILS (GP, LLZ), MKR, NDB, satellite navigation systems, surveillance system SSR A/C, SSR

mode S and ADS-B. Technical equipment consists of: AT 940 Flight Inspection System / system for monitoring of aeronautical frequency band, AT 940 Ground Reference System, EVS 300 VOR/ILS spectral analyser with antenna system EVS-Z3, FSH 18 – aeronautical spectral analyser with own antenna system.



Picture 1 – Aeronautical laboratory AeroLab 1 (source: author)

AEROLAB 2

The aeronautical laboratory AeroLab 2 is oriented to research in the field of environmental footprint of air traffic operations as well as to investigation of significant meteorological phenomenon and weather for purpose of increasing safety of the aviation. The basic tasks usually solved by this laboratory for purpose of different projects are: collecting of data about clouds (cloud base and upper level, state visibility in different kinds of clouds) turbulence, freezing, freezing level, concentration of gases in the air for environmental purposes and flow of long and short electromagnetic waves in the atmosphere. Technical equipment consists of: WVSS II Atmospheric Water Vapor Sensing System, Airborne reference station IMU/GNSS – Fiber optic Gyro.



Picture 2 – Aeronautical laboratory AeroLab 2 (source: author)

LABORATORIES OF BROKER CENTRE OF AIR TRANSPORT

Laboratories of Broker centre of air transport are primary oriented to research in the field of research and development of air traffic with continuity and effect to others research fields. The research is focused on the use of cutting-edge technology and use of outcomes of associated research activities of air transport and in terms of its interaction with

research in specific fields of electrical engineering, information technology, construction, geodesy and cartography. The result is the active participation of investigators on other projects builds on outcomes of the project, whether at national or international level.

AEROLAB 3

Aeronautical AeroLab 3 laboratory is dedicated to research in 3D spatial data acquisition of aerial imagery in the visible spectrum RGB + NIR by aerial laser scanner which was designed for corridor mapping in the transport. This technology consists of aerial laser scanner Trimble Harier 68i, supplemented with 60 Mpix camera, GNSS reference system, uninterruptible power supply unit, storage of measurement data and ground system processing and evaluating data unit. The above described technology was installed and operated in an airplane of type Piper PA34-220T Seneca III with special design for purposes of laboratory measurements. Laboratory variability adjustment allows the rear compartment for storage of all important measuring equipment on certified platforms, as well as laboratory module power supply that can supply electricity for each device, and is designed to 28V DC and 115V 60 Hz. The device is able to provide the output of the antenna GNSS and IMU output per unit in the same time.

The application of many outputs in private business environment bring possibilities to commercially link broker center and the private business environment at the regional,

national but also international level. Main focus at this levels is on outputs and innovations in the field of transport and transport infrastructure. Apart from the possible commercialization of outputs from science and research, it is necessary to highlight the possibility of collaboration with other international organizations engaged in cutting-edge research as it has already happened in case of GNSS Centre of Excellence, based in Prague.



Picture 3 – Aeronautical laboratory AeroLab 3 (source: author)

- I. Comparison of the results from assessment of surface texture measurements achieved by using 3D scanners and with using conventional methods. All assumptions are based on the contention that events which may affect the texture of the earth's surface is depended mainly on: size of the wavelengths and amplitudes, surface irregularities, micro and macro-textures (whose have a significant impact mainly on non-slip properties of roads). For chosen sections of the road communication was measured and evaluated texture and roughness of the pavement, and these sections were also scanned using a 3D scanner. The results of all the methods were compared and finally determined correlation dependence.
- II. The use of optical scanning system for continuous evaluation of variable parameters of the pavement surface is based on the obtaining and use of variable parameters about roads communication. In this cases the especially diagnosis is a source of information for analysing the condition of pavements and their subsequent evaluation. Nowadays, with the rapid development of aviation 3D laser scanning can be developed and usefulness of aerial photography in various areas especially for roads, highways, tunnels, airports and railways. High-speed cameras and optical systems provide 3D resolution with high precision and offer many advantages over conventional measurements.
- III. 3D scan can be also used for modelling of external power lines based on the data which are easily accessible and collected via Lidar technologies and therefore used for mapping corridors of power lines. On the assumption of practical results, we can see that the quality of the output data, in particular their density obtained by 3-5 points per m², is sufficient for the

purposes of monitoring and analysis of the state leadership and their protective zones.

- IV. Diagnosis of overhead power lines VVN with using aerial LIDAR is based on the use of aerial 3D scanning overhead power lines. This data together with operation of thermo camera operators can provide much valuable information for operation services. From final three-dimensional model is possible by using specialized software tools: automatically identify and vector wires, calculate deflections of wires, to inspect and define minimum distances from the wires and to identify potentially dangerous
- V. 3D terrestrial scanning of infrastructure and their parts, with consequent formation of georeferenced 3D models based on terrestrial ground scan point sample. This sample can be freely georeferenced. From measured sample of points there is possibility to make a model of 3D infrastructures or their parts. created vector models as well as the actual point sample are widely used for example in urban development and architecture, forensic and other areas of transport.

THE OTHERS SPECIALIZED LABORATORIES DESIGNATED FOR RESEARCH AND TRAINING IN AVIATION

LABORATORY OF AVIATION SAFETY, SYSTEMS AND EQUIPMENTS

Laboratory of aviation safety, systems and equipment technology is used for research in field of measurement and evaluating of conditions of aviation safety, systems and equipment technology. The laboratory is mainly focused to research in the field of navigation and communication equipment used in aviation to contribute to the safety of air traffic. HW equipment consists of a spectrum analyser FSH 4 (1 pc), FSH 18 (2 pieces), dual channel oscilloscope (1 pc), measuring receiver VOR / DME (1 pc), measuring receiver COM (voice, data) (1 pc), measuring receiver ADS-B (1 pc), antenna ground system NAV / COM (1pc). SW equipment RadioLab 3.6 for the propagation of NAV and COM signals.

LABORATORY OF AIR RADIO-NAVIGATION

Laboratory of air radio-navigation enable research on aircraft radio-navigation systems. The equipment of the laboratory (instrumentation and material) enables to perform research on the circuits and analysing of the functionality and interoperability of investigated systems. HW provided with 1 simulator FNPT II MCC the manufacturer Mechtronic, 1 simulator FNPT II MCC the manufacturer Elite, 1 pc of two-channel oscilloscope for measuring of QTG tests response

equipment. SW equipment for analysis of simulator by using QTG tests.

LABORATORY OF AVIONIC EQUIPMENT

Laboratory of avionic equipment is used for research in the field of displaying information for the flight crew. The laboratory is a specialized unit designed to work on selected aircraft avionic equipment. The laboratory allows performing of measurement and analysis of systems for non-electric measurements. The whole design of the laboratory is not only used for research purposes but also for acquiring basic procedures to monitor activities and measurements of in-flight electronic systems. HW laboratory equipment consists of 1 pc of BITD simulator including cockpit for classical instruments (analogue), 2 pieces of PCATD for research of using new LCD displays in the cockpit of an aircraft, 1 pc of multimeter, U, I, R, L, C, 1 pc two-channel oscilloscope, a set of analogic and digital avionic equipment (motor, navigational, assistance).

LABORATORY OF AIRCRAFT ENGINES

Laboratory of aircraft engines is equipped with static specimen of different types of jet engines and one piece of small jet laboratory engine. The laboratory allows to perform measurement and research of piston engine as well as monitoring of conditions of aircraft engine EDM 800. This advanced system is designed to monitor parameters of aviation piston engines. Laboratory equipment allows monitoring of selected parameters, thus becoming a professional tool mountable on board of the aircraft. HW equipment is 10 pc of monitoring and recording units EDM800, 1 pc of computer for data monitoring, 1 pc of laboratory jet engine with control unit.

LABORATORY OF AIRPORTS

Laboratory of airports is designed as a classroom for practical demonstrations and research of lighting equipment. The laboratory offers to students a comprehensive view of different solutions of individual airports and their light marking signals equipment for runways, taxiways, approach and slope lighting indicator systems, as well as for objects marking with obstacle lighting signals. This laboratory is able to examine the issue of powering for lighting systems. Another task is to offer solutions to ensure supply of aeronautical ground lighting beacons, approach lighting systems, runway and rolling lighting systems, slope indicator systems and also hole lighting systems. By use of the control and monitoring equipment, the laboratory offers opportunities for research and development of solutions for securing, controlling and monitoring of lighting equipment

and selected security systems. HW equipment consists of 20 pieces of various lighting systems (track, approach lighting system etc.), 1 pc of airport model including lighting equipment, 1 pc of power supply and airport monitoring system.

LABORATORY OF CONSTRUCTION AND OPERATION OF AIRCRAFTS

Laboratory of construction and operation of aircraft serves as a classroom for practical lessons within the subjects: aeromechanic, aircrafts and technical maintenance of aircrafts, where students solve real technical tasks and measurements in accordance with the established curricula. The laboratory is equipped with real aircraft's technique and with individual parts of aircrafts that serve as special educational instruments. Students in the lab are dealing with tasks related to use of laboratory equipment for determining gravity centre of the aircraft, verification of maintenance procedures, assessment of aerodynamic and structural characteristics of the aircraft, the analysis of properties of individual components the aircraft and many other activities relating to teaching of these subjects. Students shall verify by these operations their theoretical knowledge to actual aircraft equipment, what significantly improve whole educational process. The laboratory consists of aircraft types Zlin 42 and Zlin 142, rudders, elevators, ailerons, wings body parts, machinery wings, landing gear systems as well as all necessary technical equipment.

CONCLUSION

Research and educational laboratories, as well as projects focused on scientific and research activities have a role to contribute to enhancing the quality of the educational process as well as involved to better quality of science and research. The project solutions of this type should to be elementary and compulsory baseband for each university, due to still rising requirements for equipment and information-communication equipment of workplaces. Projects like this are a proof of the rapid growth of scientific knowledge that result in demands on the experimental verification of knowledge and technology by using the virtual reality and various simulation which follows the trends of nanotechnology and the most modern information and communication technologies. Common task for all projects, mentioned in this article is to create a unique monitoring and evaluation systems for air traffic in the area of Slovakia. The main purpose of these monitoring systems is future participation in the research of innovative technologies used in the field of transport, which brings benefits mainly for possible sharing or even pooling

of knowledge that should simplify their verification, comparison and improve complexity within the EU region. Intensive connection between research and practice will establish partnerships at university level and will reflect into increasing quality of science and research in Slovakia.

ACKNOWLEDGEMENT

This paper is published as one of the scientific outputs of the project: „The research on virtual reality elements application: the significant improvement of simulator performance characteristics “ITMS: 26220220167“.



We support research activities in Slovakia/

Project is co-financed by EU

REFERENCES

[1] Novák Sedláčková, A.: Propagácia Brokerského centra leteckej dopravy pre transfer technológií a znalostí do dopravy a dopravnej infraštruktúry v kontexte technologického transferu a jeho právne-ekonomického rámca. In: Brokerské centrum leteckej dopravy pre transfer technológií a znalostí do dopravy a dopravnej

infraštruktúry: zborník vedeckej konferencie: Donovaly, 22.-24.01.2014. - Žilina: Žilinská univerzita v Žiline, 2014. - ISBN 978-80-554-0877-4. - S. 71-73.

- [2] Novák Sedláčková, A. – Novák A.: Žilinská univerzita v Žiline, Katedra leteckej dopravy realizuje projekt Centrum excelencie pre leteckú dopravu / Alena Novák Sedláčková, Andrej Novák. - Žilina: EIP/services, 2013. - 43 s.
- [3] Novák, A. a kol.: Využitie výskumných letových laboratórií vo svete a EÚ - Žilina: [s.n.], 2012. - 68 s.
- [4] Pitor, J – Kandra, B.: Problém laserového skenovania členitého terénu, In: Aero-Journal: international scientific journal of air transport industry. - ISSN 1338-8215. - Č. 1 (2014), s. 29-34.
- [5] Bugaj, M. Rostáš, J. Němec, V.: 3D modeling from airborne laser scanner = 3D modelovanie dát získaných z leteckého laserového skenera, In: GEO SPATIAL VISIONS: vedecká konferencia: Banská Bystrica, 08.-09.09.2015. - Žilina: Žilinská univerzita, 2015. - ISBN 978-80-554-1113-2. - S. 15-16.
- [6] Bugaj, M. Cíger, A. Jirků. P.: Comparison of helicopter simulators and modelling, In: INAIR 2014: international conference on air transport: 13-14 November 2014, Prague, Czech Republic. - Žilina: Žilinská univerzita, 2014. - ISBN 978-80-554-0944-3. - S. 19-21.
- [7] Bugaj.M.: Riadenie zdrojov v systéme údržby, In: Aero-Journal: international scientific journal of air transport industry. - ISSN 1338-8215. - Vol. 1, no. 1 (2012), s. 53-58.

ANALYSIS AND SIMULATION OF AIR COLLISION AVOIDANCE SYSTEM

Maxim Solkin

Faculty of Engineering, Swansea University, UK

jokerDiLife@gmail.com

Pavel Loskot

Faculty of Engineering, Swansea University, UK

p.loskot@swan.ac.uk

Abstract – This paper considers some important aspects of the design of Collision Avoidance System (CAS) for aerial vehicles which is a fundamental technique used in commercial TCAS. In particular, we focus on statistical inference of the range and bearing in order to improve accuracy of determining the intruder aircraft trajectory. A nonlinear regression moving window filter is used to suppress the systematic and measurement noises. The systematic errors are modeled as 1st-order Markov processes, and the measurement noises are assumed to be nonstationary. A standard kinematic conflict model of the encounter between two converging aircraft is considered to estimate tau, the time to Closest Point of Approach (CPA). Improvement of the bearing error and future trends of CAS systems in aviation are outlined.

Key words - Collision avoidance; Angle-of-Arrival; antenna array; statistical inference; phase-interferometry; regression.

INTRODUCTION

Air Collision Avoidance System (ACAS) is an important component increasing the safety of aviation. A number of ACAS systems are available including well known TCAS which is used by the airliners and large aircraft, and FLARM which is intended for use by general aviation. These systems are most useful for situations when two aircraft are flying on convergent trajectories. The corresponding conflict geometry of such scenario is illustrated in Figure 1, and the relevant flight and geometry parameters are listed in Table 1. In Figure 1, the TCAS equipped aircraft 1 is tracking so-called intruder aircraft 2 by measuring its bearing and range. Knowing also the speed of the intruder (both aircraft speeds are, in general assumed to be constant), the TCAS aircraft is estimating the miss distance at CPA, and may possibly issue traffic or resolution advisory (respectively TAs or RAs) to the pilot.

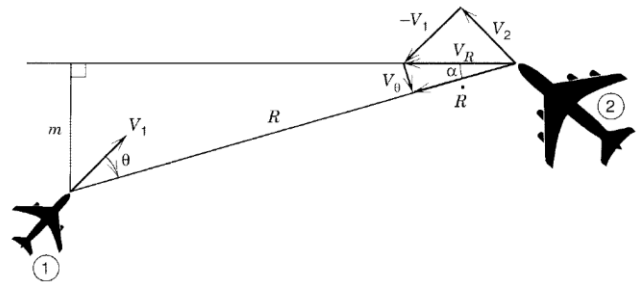

Figure 1: Conflict geometry of two aircraft on converging trajectories. (Source: Kayton and Fried [1])

Table 1: Definition of parameters in Figure 1

Symbol	Meaning
CPA	Closest Point of Approach
R	distance or Range between the two aircraft
V_R	relative velocity between the two aircraft
T	true (exact) time for intruder (aircraft 2) to reach CPA
m	miss distance which is equal to the distance between the two aircraft at CPA
V_θ	tangential velocity of aircraft 2 with respect to aircraft 1
V_1	velocity of aircraft 1, assumed constant in general
V_2	velocity of aircraft 2, assumed constant in general
α	relative bearing angle, such that $\sin \alpha = \frac{m}{R} = \frac{V_\theta}{V_R}$
θ	intruder bearing or angle-of-arrival
$\dot{\theta}$	time derivative of the intruder bearing (or, simply, the bearing rate)
\dot{R}	time derivative of range between the two aircraft (or, simply, the range rate)

τ	<p>estimated time to CPA equals $\tau = -\frac{R}{\dot{R}}$</p> <p>Note that always $\tau \geq T$ (the true time to CPA), and that τ increases w.r.t T as m/V_R gets bigger [1].</p>
--------	--

DESCRIPTION OF AIRCRAFT CONVERGING TRAJECTORIES

We first illustrate the trajectories for two converging aircraft. Figures 2 and 3 show respectively, the range (separation) and bearing of the two aircraft for 4 different scenarios: in case 1, both aircraft are in level flight at the same altitude; in case 2, both aircraft are in level flight but the intruder is 1,000 feet below the TCAS-equipped aircraft; in case 3, the intruder is descending towards the altitude of the TCAS aircraft; and, in case 4, the TCAS aircraft is also climbing towards a descending intruder. We observe that only in the first case, the range is linearly decreasing with time, and the corresponding bearing is also decreasing with time, but not linearly.

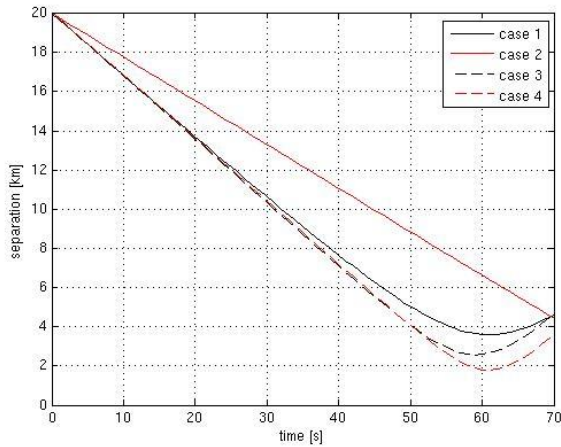

Figure 2: Range trajectory of two converging aircraft.

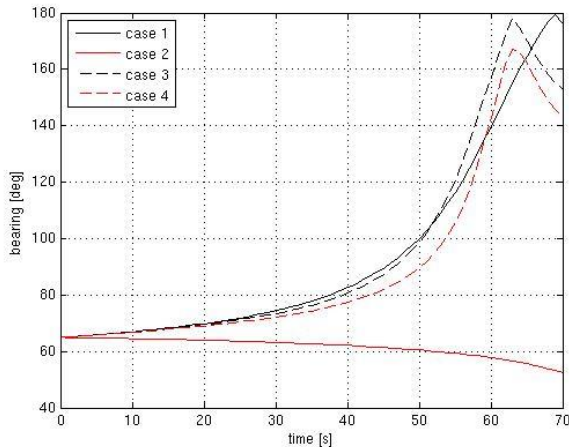

Figure 3: The bearing trajectory of two converging aircraft.

Assuming Figure 1 and Table 1, and after some straightforward but lengthy manipulations, we can obtain the basic expressions for the miss distance and the time derivative of the AoA (the bearing rate) [2], respectively, as:

$$m = \frac{\dot{\theta} R^2}{\sqrt{\dot{R}^2 + (R\dot{\theta})^2}} \quad (1)$$

$$\dot{\theta} = \frac{m V_R}{T^2 V_R^2 + m^2} \quad (2)$$

ESTIMATION OF TIME TO MISS DISTANCE

The bearing rate is estimated using expression (2), and this estimate can be then used in expression (1). As suggested in [1], for a miss distance of 1 nmi (nautical mile), relative speed of 300 knots and true time to CPA of 25 sec, it can be shown [2] that these values yield a bearing rate in the order of approximately 1 deg/s. Furthermore, for these same quoted typical values, the resulting error of the bearing rate estimation ($\delta\dot{\theta}$) has been found to be in the order of about 10^{-1} to 10^{-2} deg/s [2]. These estimates are in a good agreement with the values which are typically quoted in the literature; see, e.g., [1] and [3]. The actual time to miss distance is estimated as,

$$\tau = -\frac{R}{\dot{R}} \quad (3)$$

After some manipulations [2], it can be shown that,

$$\tau = \frac{T}{\cos^2\left(\tan^{-1}\frac{m}{V_R T}\right)} \quad (4)$$

This relationship between the estimated and true times to the CPA is most crucial for defining the rules to avoid the potential collision. We can further consider the behavior of τ versus T . This leads to the concept of so-called Sensitivity Level (SL) which assigns a designated time threshold for a given (calculated) miss distance estimate. It can be then used to trigger or suppress RA alarms associated with TCAS logic. In order to establish required values of different SLs, we have used an Excel spreadsheet and followed these steps:

1. Given a miss distance m (in nmi, starting with some small value, say, $m = 0.2$ nmi), plot the τ vs. T curve, as per (4) in order to determine the appropriate sensitivity level to be used by the TCAS RA logic, i.e. consulting a *table* to issue the correct RA, or suppress it if the criteria is not satisfied.
2. For a specific value of m (say, 0.5 nmi), the SL is determined such that the value of τ (recall that it is always greater or equal to T) begins to decrease and eventually converges to T (note that some oscillations may occur near

the critical value of T). Simply stated, for this particular range value SL holds that $T \leq 19$ sec value, yielding a particular value of τ equal to 17.7 sec, as can be shown by Table 2, generating the values obtained from the calculations in step 1 and 2:

Table 2: Determination of Sensitivity Levels for triggering a resolution advisory (RA)

Vertical separation m in nm	Sensitivity Level in terms of true time T	Actual estimated value of τ , 1 dp	1 sec time intervals
0.2	$T \leq 15$ s or $T \leq 12$ s	$\tau \approx 14.5$ s or $\tau \approx 10.9$ s	15-14 s or 11-10 s
0.5	$T \leq 19$ s	$\tau \approx 17.7$ s	18-17 s
1	$T \leq 19$ s	$\tau \approx 19.7$ s	20-19 s
1.5	$T \leq 19$ s	$\tau \approx 18.7$ s	19-18 s
2	$T \leq 25$ s	$\tau \approx 24.9$ (17.9 a bit more off)	25-24 s
3	$T \leq 30$ s	$\tau \approx 29.9$ s	30-29 s
5	$T \leq 35$ s	$\tau \approx 35$ s	36-35 s

3. Once the SL value has been established for a particular value of m , we compute $\hat{\theta}$, and then in turn $\delta\hat{\theta}$ at one second time intervals around the convergence zone. We then form pairs $(m, \delta\hat{\theta})$ and plot the miss distance values versus the error in the bearing rate ($\delta\hat{\theta}$) for each value of m during the critical one second time interval; this is shown in Table 3.

Table 3: Miss distance versus bearing rate error around the 1-sec time interval

miss distance m [nmi]	0.2	0.5	1	1.5	2	3	5
bearing rate error $\delta\hat{\theta}$ [deg/s]	0.09 OR 0.22	0.1	0.1	0.09	0.05	0.03	0.01

Assuming values in Table 3, the bearing error versus the miss distance can be plotted as shown in Figure 4. We observe that the error is in the order of around one-tenth to two-tenth degrees per second.

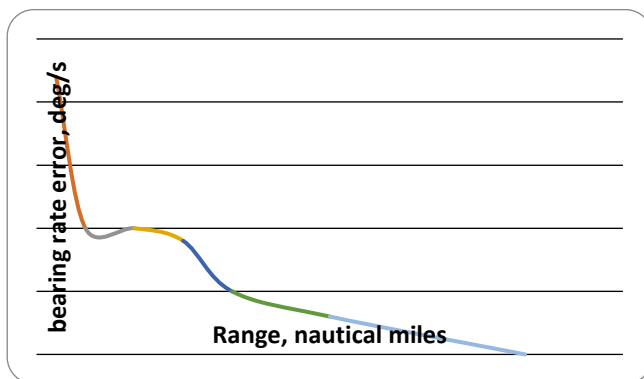

Figure 4: Miss distance (nmi) versus the bearing (AoA) error (deg/s).

Recalling step 2 above, our Table 2 demonstrates the following test case, suggested in [1]: calling on (4), for particular miss distance values 0.5, 1 and 1.5 nm, relative velocity of 300 nmi, and a TCAS alarm that ‘requires a τ less than 20 sec as condition for displaying an RA’ [1], RAs for 1 and 1.5 nm miss distances will be *suppressed*, while an RA for a 0.5 nmi miss distance will be triggered, as it has well inside the critical 20 sec threshold by a small, but not too small a margin of error as to constitute a nuisance.

IMPROVED ESTIMATE OF TAU

Recall eq. (3) and consider again Table 2. Notice also that the bearing error increases with decreasing aircraft separation. Here we consider more precise expression for ‘tau’ than (3) which is motivated by the problem of the intruder accelerating at a small rate towards the TCAS (own) aircraft. Following [3, eq. (17)], we modify eq. (4) as:

$$\tau_{modified} = -\frac{R^2 - DMOD}{R \dot{R}} \quad (5)$$

$$\tau_{modified} = -\left(\tau_{old} - \frac{DMOD}{R^2} \cdot \tau_{old}\right) \quad (6)$$

where DMOD is the designated horizontal distance (range) threshold which is used by the logic to trigger RA alarms. It can be shown [2] that the range R can be expressed as:

$$R = \sqrt{T^2 V_R^2 + m^2} \quad (7)$$

STATISTICAL INFERENCE OF RANGE AND BEARING

As we observed in Figure 2 and 3, there are many scenarios where neither range nor bearing would be changing linearly with time. In order to carry out statistical evaluation of estimating these parameters, we need to first obtain their stochastic models. Once these models are defined, we will consider sliding window nonlinear regression as one possible technique to estimate their values.

Denote as $R(t)$ and $B(t)$ the true values of the intruder range and bearing, respectively. Our task is to estimate these values. The models of the measured signals for the range and bearing, respectively, can be written as follows:

$$y_R(t) = R(t) + R_1(t) + w_{R(t)} \quad (7)$$

$$y_B(t) = B(t) + B_1(t) + w_{B(t)} \quad (8)$$

where $R_1(t)$ and $B_1(t)$ represent systematic errors, and $w_{R(t)}$ and $w_{B(t)}$ are the measurement noises. The systematic errors reflect the correlated measurements of the bearing shown in Figure 2 in reference [3]. They are modeled here as zero-mean mutually correlated 1st-order Markov processes (i.e., given their value for some $t=t_0$, the future values for $t>t_0$ are completely independent of past values for $t<t_0$), so the values are correlated in time as well as in-between these processes. The cross-correlation of $R_1(t)$ and $B_1(t)$ is

attributed to the physics behind wave propagation that is common to both processes; as explained in [3], the aircraft movement changes the reflective surfaces for the radio waves which in turn affects the range and bearing measurements received by the TCAS aircraft). The Markov process can be generated as an autoregressive moving average (ARMA) process. The uncertainty random process driving the ARMA stochastic signal model is assumed to be zero-mean, stationary white Gaussian process. The measurement noises $w_{R(t)}$ and $w_{B(t)}$ are also zero-mean, mutually uncorrelated, white and Gaussian processes. However, these noises are assumed to have nonstationarity trend in order to model the dependence of the measurements on the distance (i.e., range) between the own aircraft and the intruder as indicated in Figure 1 of reference [3] (i.e., the closer the intruder, the less noisy are the measurements). The statistical estimation of the range and bearing suppresses the additive noises $R_1 + w_R$ and $B_1 + w_B$, respectively. The estimation is often performed by so-called on-line estimators which are effectively filters. Kalman filter and its variants are particularly popular choices in many applications due to their fast convergence to changing signal and noise statistics. These filters require only modest assumptions about the measurement signal in order to be effective. Here, we consider a nonlinear regression with least-squares criterion to suppress the additive noises. The regression estimators do not require any assumptions. In addition, we apply the regression over a moving window of finite length. Thus, the most recent observed samples of range $R(t)$ and $B(t)$ (t is the current time) are estimated by minimising the least squares metrics:

$$LS_R(t) = \sum_{i=\max(1,t-K+1)}^t (y_R(t) - \hat{R}(t))^2 \quad (9)$$

$$LS_B(t) = \sum_{i=\max(1,t-K+1)}^t (y_B(t) - \hat{B}(t))^2 \quad (10)$$

where K is the window length (in samples), and \hat{R} and \hat{B} are estimates of the true values of range and bearing, respectively. Expressions (9) and (10) represent objectives of a multi-objective optimization problem. Such problems are normally solved by so-called regularisation which combines all objectives into a single function, often to minimise a weighted sum:

$$LS(t) = W_1 LS_R(t) + W_2 LS_B(t) \quad (11)$$

However, the LS values for R and B can often have very different values which can change significantly over time. This makes finding suitable weights for each time instant difficult. For this reason, we minimise the LS values for R and B alternatively, in succession. Thus, the LS for R is minimised first over the values of R and B , and these new values are then used as initial estimates for minimising the LS sum for B . Our numerical results indicate, as expected,

that the lower the signal-to-noise ratio (the higher the levels of background noises and the ARMA process uncertainties), the larger should be the value of K (the moving window length over which the regression is calculated). However, since the previously estimated values of $R(t)$ and $B(t)$ (before the current time t) can be used as the initial values in each time instant when we numerically minimise the LS value, the number of iterations required in each time instant can be relatively small. For our experiments in this paper, we used $K=20$ and we also limited the total number of iterations in each time instant to 50 (a modest value significantly limiting the amount of computations).

Figures 5 and 6 show one realization of the noisy measured range and bearing, respectively, in a scenario where the CPA is reached at $t=60$ seconds after the start of the measurements taken every 1 second.

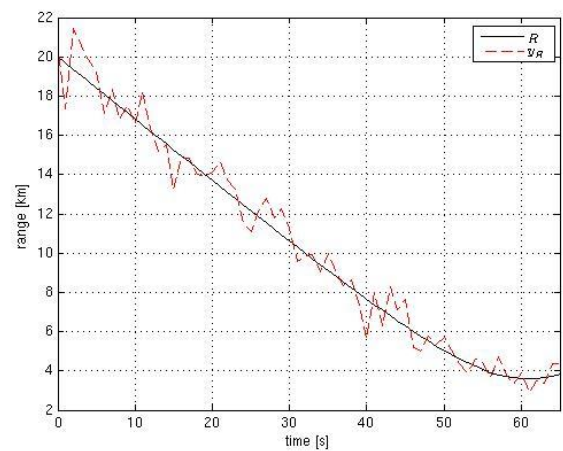

Figure 5: Noisy range measurements.

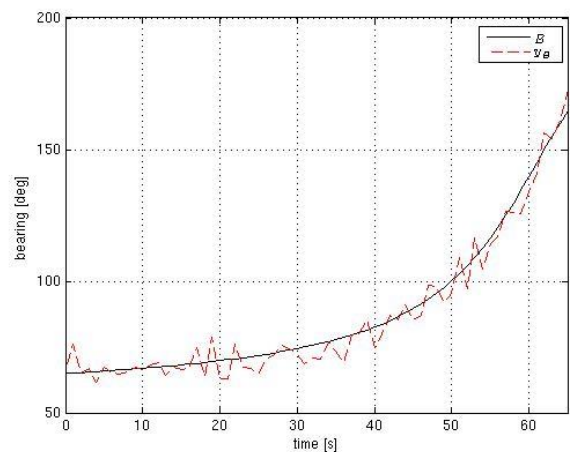

Figure 6: Noisy bearing measurements.

The results of filtering the noisy signals in Figure 5 and 6 by nonlinear regression are shown in Figure 7 and 8, respectively. We can observe that the noises have been mostly suppressed. It may be possible to employ another regression estimator at the second stage after the first one, and with a larger window length K in order to further reduce

the estimation errors (to almost zero, except close to the start of the measurements). However, in practice, TCAS requires only the estimates of the current values of $R(t)$ and $B(t)$, so further processing to improve the past estimates is irrelevant.

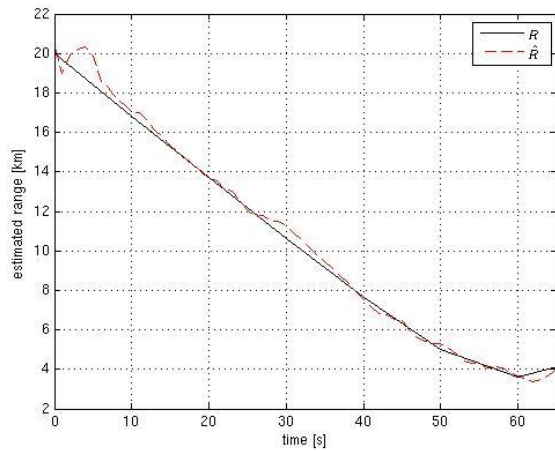

Figure 7: The range signal after regression filtering.

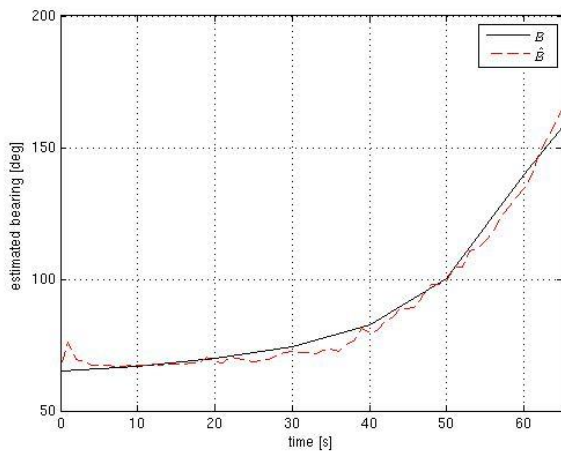

Figure 8: The bearing signal after regression filtering.

FUTURE OF AIR COLLISION AVOIDANCE SYSTEMS

The bearing error has proven to be a significant source of error and an engineering challenge for airborne radars. For this reason, other methods have been suggested to improve the accuracy of bearing measurement. One such method is

radar interferometry [4]. Phase-interferometry is utilized as a low-complexity solution to mitigate the bearing rate estimation errors associated with the commonly used monopulse antenna. Algorithms for the estimation of AoA measurement using phase interferometry are already discussed in the literature [4], [5]. However, the authors of this paper observe that an important basis on which such algorithms are found, e.g. the far-electromagnetic field assumption may not always be satisfied. This calls for a statistical error model to quantify the associated probability error when interferometry is used.

On the other hand, current trends in aviation collision avoidance systems for both general and commercial aviation seem to combine such improvements with more versatile technology. In this respect it has been suggested to integrate antenna-based systems with Satellite-based systems, e.g. ADS-B. However, these innovations introduce other types of challenges. Big among these is the problem of aviation security, particularly in controlled airspace.

REFERENCES

- [1] Kayton, M. and Fried, W. R., "Avionics Navigation Systems", 2nd ed., John Wiley & Sons, 1997.
- [2] Solkin, M. A., "Conceptual Design of a Collision Avoidance for General Aviation Aircraft with some Treatment of Drones", ongoing M.Sc Thesis, Swansea University, 2016.
- [3] Burgess, D. W. and Altman, S. I., "TCAS III Bearing Error Evaluation", Project Report, MIT, US, 13 April 1995.
- [4] Holder, E. J., "Angle-of-Arrival Estimation Using Radar Interferometry: Methods and Applications", SciTech Publishing, 2014.
- [5] Guerin et al, "Passive Direction Finding: A Phase Interferometry Direction Finding System for an Airborne Platform", Bachelor of Science Thesis, Worcester Polytechnic Institute, October 2012.
- [6] Kay S., "Estimation and Detection Theory," Prentice Hall, 2001.
- [7] Boyd S. and Vandenberghe V., Convex Optimization, Cambridge Press, 2004.

AUTHOR INFORMATION

Max Solkin, M.Sc student, College of Engineering, Swansea University, UK.

Pavel Loskot, Senior Lecturer, College of Engineering, Swansea University, UK.

AIR TRAFFIC MANAGEMENT AND WEATHER: THE POTENTIAL OF AN INTEGRATED APPROACH

Martin Steinheimer, Carlos Gonzaga-Lopez, Christian Kern, Markus Kerschbaum, Lukas Strauss

Austro Control GmbH, Vienna, Austria

martin.steinheimer@austrocontrol.at

Kurt Eschbacher, Martin Mayr, Carl-Herbert Rokitansky

Aerospace Research Group, University of Salzburg, Austria

roki@cosy.sbg.ac.at

Abstract - Wind and adverse/severe weather have a significant impact on air traffic management (ATM). Various performance figures related to safety, capacity, cost-efficiency and environmental impact have to be considered and optimized. ATM decisions currently rely on strictly deterministic information, while it would be more reasonable to use a probabilistic approach to account for the intrinsic uncertainty of the meteorological (MET) information. First results of the ongoing project MET4LOWW¹⁵ aiming at reconciling the uncertainty of weather and strictly deterministic ATM procedures in a holistic ATM/MET approach for optimal arrival and departure management are presented. The quantitative assessment is based on ATM key performance indicators (KPI) derived from fast-time air traffic simulations in terminal airspace. In addition, the simulated traffic is qualitatively assessed by air traffic controllers. Based on this analysis the ATM/MET procedures will be optimized.

Key words - Weather, air traffic simulation, terminal airspace, key performance indicators, probabilistic weather forecasts.

BACKGROUND

Weather has big impact on air traffic management (ATM). When considering airport capacity the most important weather elements are wind, thunderstorms and low visibility.

The weather cannot be changed, but accurate forecasts help to minimize its impact on the air traffic system. One way to quantify the impact of weather is to look at flight delays. Table 1 shows the arrival delays for Vienna International Airport (LOWW) for the period of October 2015 to March 2016. As there was almost no snow in Vienna during that period, these delays were mainly caused by low visibility.

Considering a common estimate for delay cost of 80 Euro per minute, the economic impact is obvious.

Table 1 Arrival delays Vienna International Airport
October 2015 to March 2016
(Source: Austro Control Strategic Market Analysis and Forecast Team)

	minutes	minutes/flight	percentage
Weather	66214	0.59	89%
Total	74121	0.66	

Austro Control, the Austrian air navigation service provider, together with the Aerospace Research Group of University of Salzburg and the German Aerospace Center initiated the project MET4LOWW¹⁵ in order to assess the impact of weather, the benefit due to currently used weather forecasts and potential improvements to weather forecast products and their utilization within ATM.

Within this project the impact of weather on airport approach and departure is evaluated using basic Arrival/Departure Manager techniques. This includes avoidance of weather objects (e.g. thunderstorms) by aircraft and assessment of wind impacts on airport and airspace capacity. The quantitative assessment is based on ATM key performance indicators (KPI) derived from fast-time air traffic simulations. In addition, the simulated traffic is qualitatively assessed by air traffic controllers. Based on this analysis the ATM/MET procedures will be optimized.

To carry out the simulations, standard instrument arrival and departure procedures at LOWW and handling of wind and

¹⁵ The project MET4LOWW is funded by the Austrian Research Promotion Agency in the framework of the TAKE OFF program.

weather objects are integrated in the ATM/ATC simulator NAVSIM used by University of Salzburg. Realistic avoidance algorithms for weather objects (e.g. thunderstorms) and the accurate simulation of the impact of wind on aircraft on final approach are key prerequisites to estimate the impact on landing capacity and on traffic-flow and -complexity in upstream air traffic control sectors.

With the air-traffic simulation approach, the potential of integrated ATM/MET procedures can be evaluated from different perspectives. The benefit of improved weather information can be identified by sensitivity studies of weather impact on KPIs. This allows to determine the required accuracy of weather forecasts in terms of temporal/spatial resolution as well as forecasted thresholds can be assessed. Furthermore, the use of probabilistic weather information to improve ATM efficiency on average, while maintaining safety levels in each individual case, can be investigated.

The simulation results are expected to help to tailor weather information to the specific needs of ATM, both in deterministic form for current ATM procedures and in probabilistic form for future ATM procedures where weather information should be an integral part.

A better integration of weather information into the operational ATM-system will ultimately improve the overall air traffic safety and efficiency.

EVALUATION METHOD

It is common in ATM to measure performance in various Key Performance Areas (KPAs; cf. ICAO 2009). This approach is adopted here for the weather impact analysis by looking at four KPAs: capacity, environmental impact/flight efficiency, cost-effectiveness and traffic complexity. Traffic complexity is used as a proxy for safety, as safety cannot be measured directly with deterministic simulations such as the ones used in this study.

Each KPA is represented by at least one Key Performance Indicator (KPI), where each KPI has to meet several criteria. First of all the standard criteria according Eurocontrol (2011): specific, measurable, drive the desired behaviour, accountable/manageable and compatible with ICAO guidelines (ICAO 2009). But most importantly for the presented evaluation, the KPIs need to be proper with regard to weather forecasts, i.e. the measure must be optimized by forecasting one's true believe. For example: traffic complexity would be lowest for no air traffic at all, so it could be minimized by always predicting worst conditions, which would result in maximum air traffic restrictions.

Figure 1 gives an overview of the experiment setup used for the evaluations in this study. In the centre of the evaluation is the air traffic simulator which will be described in more detail in the next section. The main inputs for the experiments are weather and air traffic. For both inputs real or synthetically generated data can be used.

In a first step the actual traffic used in the simulation is derived from the weather forecast input and air traffic demand by applying appropriate ATM measures. Possible

measures are traffic regulations (delay flights on ground), increased air traffic controller staffing (open additional sectors) or other short-term measures (delay traffic in upstream air traffic control units).

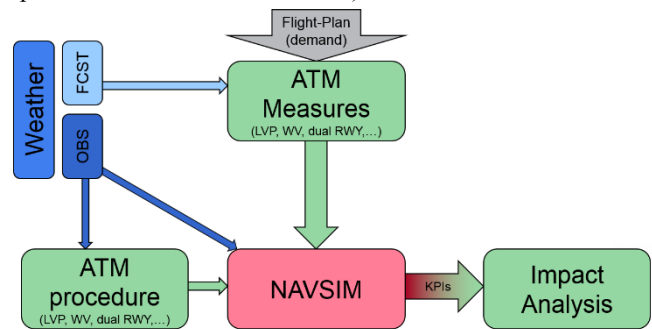

Figure 1 Weather impact analysis flow chart.

In a second step, the corresponding ATM procedures (e.g. separation on final approach, runway configuration, traffic routing), are derived based on the observed weather and used to configure the simulation. The simulation results are the input for the impact analysis, which derives the KPIs, including an estimate of the economic value of the weather forecasts.

The impact analysis follows an approach widely used in meteorology (Murphy, 1966; Richardson, 2000) which was adapted to the use of KPIs. It is based on the contingency table of the forecast (see Figure 2), which gives an idea of the forecast quality. The table gives the relative count of correctly forecasted events (hit rate – h), missed forecasts (m), false alarms (f) and correct negatives (n).

		Observed	
		Yes	No
Forecasted	Yes	<i>hit</i>	<i>false alarm</i>
	No	<i>missed</i>	<i>Correct negative</i>
		$o = h + m$	$1 - o$

Figure 2 Forecast contingency table (o is climatological frequency).

Using this contingency table, the economic value can be evaluated with a cost matrix based on monetary value. Some processes, like safety, cannot be satisfactorily measured monetarily. In addition, many different stakeholders are involved, whose costs are not easily accessible. For those reasons we use a weighted combination of relevant KPIs instead of monetary value in the cost matrix (Figure 3). The values in the cost matrix can be derived for a specific weather event from following simulations:

- KPIh: weather event occurs in simulation and ATM measures, e.g. traffic regulations, are applied according to the weather forecast.

- KPIf: weather event does not occur in simulation and ATM measures are applied according to the weather forecast.
- KPI_m: weather event occurs in simulation and no ATM measures are applied.
- KPI_n: weather event does not occur in simulation and no ATM measures are applied.

		Observed	
		Yes	No
Take action	Yes	<i>KPI_h</i>	<i>KPI_f</i>
	No	<i>KPI_m</i>	<i>KPI_n</i>

Figure 3 Cost matrix based on KPI combination.

There is of course no unique cost matrix for every weather event as based on the given forecasts and related ATM procedures the taken ATM measures can vary. This sensitivity is evaluated to identify potential improvements both for the forecasts and ATM procedures.

The ratio of cost, for taking preventive action against an event, to the loss averted is an important prerequisite for the effective use of probabilistic forecasts. This so-called cost-loss ratio is the threshold probability above which it is beneficial to take preventive action. The cost-loss ratio for a given weather event can be derived from the cost matrix. From the forecast contingency table the potential economic value (Richardson, 2000) can be derived as a function of cost-loss ratio independent of the cost matrix (Figure 4).

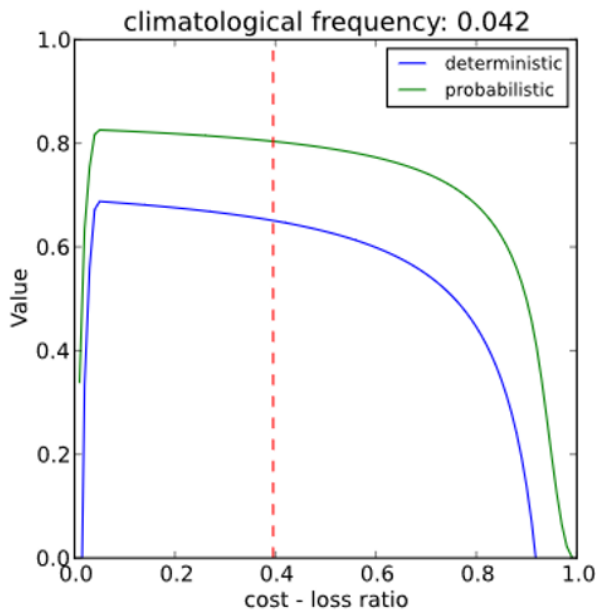

Figure 4 Potential economic value of a two hour low visibility procedure forecast at LOWW. The curve for the

deterministic forecast (blue) is based on verification results. The probabilistic curve (green) and the cost-loss ratio (red-dashed) are estimates not actual evaluation results.

The range of the potential economic value is zero to one. The perfect forecast would give value one and value zero means that the forecast has no value over using only climatology. The potential economic value shows what fraction of a perfect forecast's benefit can be realised by using the given forecast.

The actual economic value of a particular forecast product, measured in terms of the KPI combination, can be derived from the respective cost matrix and contingency table. Using this value, different forecast products can be compared.

A major challenge for the described evaluation is to determine the weighted KPI combination used in the cost matrix. This is difficult because some of the KPIs are contradictory, e.g. there is a trade-off between maximizing capacity and optimizing workload. In addition the various involved stakeholders (air navigation service provider, airlines, airport) associate different priorities to the KPIs, e.g. ATM workload is not an airlines' first priority. For the results shown here a simple approach with estimated weights was taken. Later on in the MET4LOWW project a more sophisticated approach following De Reyck et al (2006) will be investigated.

AIR TRAFFIC SIMULATOR

In this study, NAVSIM¹⁶, a very sophisticated air traffic simulator, is used for the simulation of various weather and traffic scenarios. It is capable of world-wide runway-to-runway as well as gate-to-gate, air traffic simulations. It incorporates sophisticated simulation techniques based on detailed aircraft performance data and around one million navigation data¹⁷. More than ten thousand aircrafts can be simulated simultaneously, including a generic flight management system (FMS) for each aircraft, in real-time or fast-time mode. The design of NAVSIM is very modular, what allows inclusion of third party test equipment and products such as the wake vortex model of the German Aerospace Center, which will be used in a later phase of the MET4LOWW project.

For the presented study, advanced arrival manager functionality was integrated into NAVSIM to resemble the LOWW arrival procedures. This includes:

- Detailed Arrival Management of all aircraft (starting calculation about 200 NM to 80 NM ahead of destination aerodrome at "entry point")
- Detailed Merge Point Calculation (e.g. IF or Final Approach Fix FAF) overfly time based on 3 basic modes: Direct Mode (no transition required), Transition Mode and Holding Mode (if required)
- For each flight, the flight path geometry as well as the length and Calculated Time of Arrival (CTA)

¹⁶ NAVSIM ATM/ATC/CNS Tool is developed by Mobile Communications Research & Development Forschungs GmbH in cooperation with University of Salzburg.

¹⁷ Courtesy of Jeppesen GmbH, Neu-Isenburg, Germany.

are computed at entry point and remain stable (unless adjustments to flight behaviour and or current weather situation becomes necessary) until touch down on arrival runway

- Continuous Descent Approach (CDA) with a descent angle of 3 degrees is calculated and executed at entry point
- For wake turbulence calculation the wake category for each aircraft type is assigned according to ICAO rules (ICAO 2016) or (new) RECAT rules (Eurocontrol 2015) and taken into account during Departures, within TMA and on Final Approach
- Distance Based or Time Based minimum Separation on Final Approach are selectable and taken into account in Arrival Management calculations
- Low visibility procedures (increased minimum separation distances or time) are taken into account in all arrival management calculations
- Wind profiles per runway / within area are taken into account
- In case of adverse weather (CBs), the optimized weather avoidance path is calculated based on observation and nowcast data.
- Harmonization between departing and arriving air traffic is taken into account by NAVSIM/AMAN
- Synchronous arrivals on parallel and/or crossing runways are possible
- NAVSIM/AMAN allows comparison between optimized flights and “best practices” based ATCO controlled flights (based on track/CPR data)
- Data needed for detailed performance analyses in terms of KPIs is calculated and recorded from NAVSIM/AMAN simulations

An important milestone of the study was the validation of the simulator performance. Actual flight paths were compared to simulated flight paths. Accordingly, the simulator was initialized with real traffic at standard arrival route (STAR) endpoints. The simulated trajectories between those points and touch down were compared to the respective actual flight trajectories.

In order to achieve realistic simulations three arrival modes were implemented:

1. *direct mode*: applied in case of low traffic. Flights go directly from the start point towards the final approach fix, intercepting the runway center line.
2. *transition mode*: to have more space if traffic is higher, so-called arrival transitions are used to guide the flights from the STAR endpoint to final approach, thereby reducing the need of radar vectoring.
3. *holding mode*: if traffic is too high for the transition mode, flights have to wait in holding patterns located at the STAR endpoints.

The arrival modes are depicted in the LOWW approach chart in Figures 5a-c.

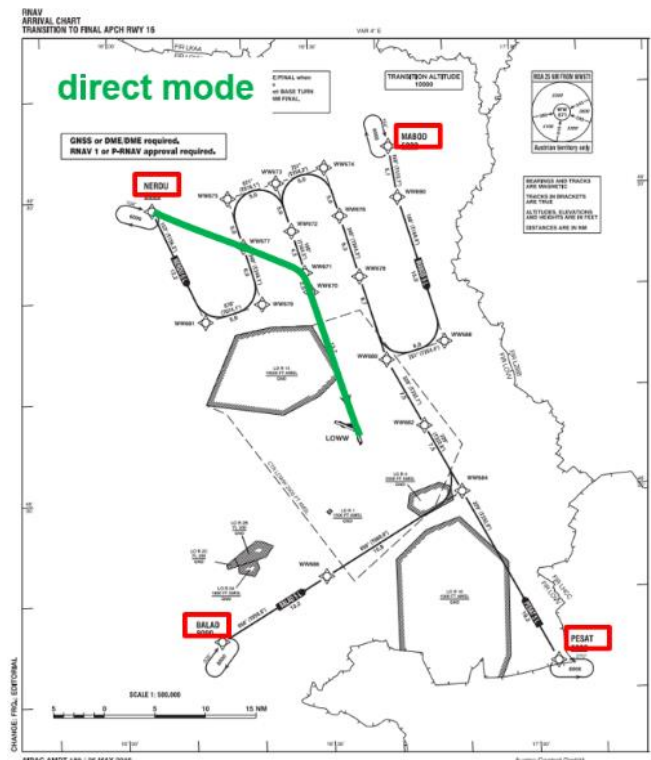

Figure 5a LOWW approach chart (Austro Control 2016). Arrival mode direct is indicated by green line. STAR endpoints highlighted red.

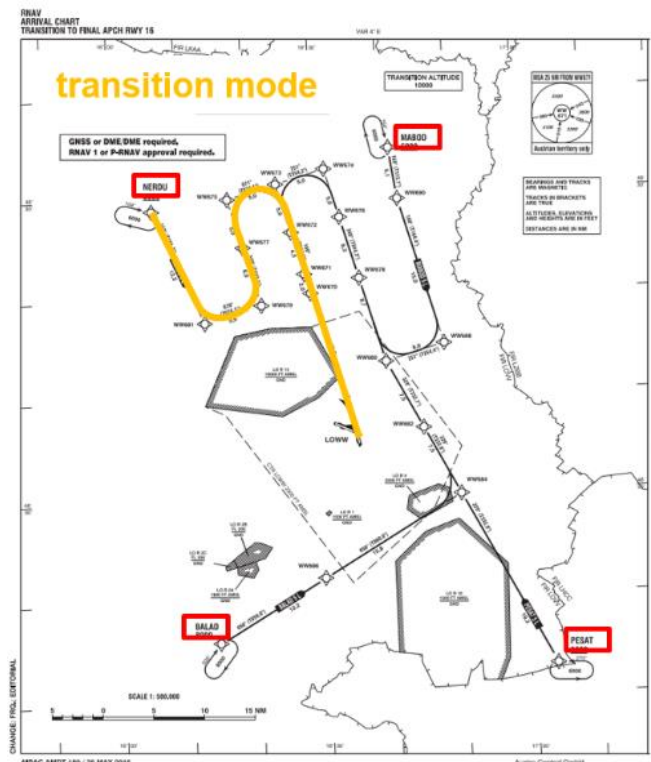

Figure 5b As Figure 5a but for transition mode (yellow).

RESULTS

Results for two low visibility procedure (LVP) events are discussed. LVP has big impact on airport capacity. It reduces airport capacity from 40 arrivals per hour under normal conditions to 25 or 18, depending on the runway visual range (RVR). Table 2 lists the LVP states in use at LOWW.

Table 2 LVP states in use at LOWW.

LVP state	RVR	Ceiling	Separation	Capacity
normal			2.5NM	>40
LVP	<600m	or < 200ft	4NM	25
LVP CATIII	<350m		6NM	18

Traffic demand and traffic load per 30 minutes intervals for the two LVP events are depicted in Figures 7 and 8. For the long LVP event shown in Figure 8, one can see that the traffic peaks of the demand are smoothed out over the day in the traffic load, what results of course in significant delays.

LVP status derived from MET state (METREPORT + RVR) + RWY in use
 LVP colors: yellow: LVP STDBY, red: LVP, magenta: LVP CAT3
 RWY in use colors: light green: ldg, blue: dep



CHMI landing rate 20160413(per 30min)

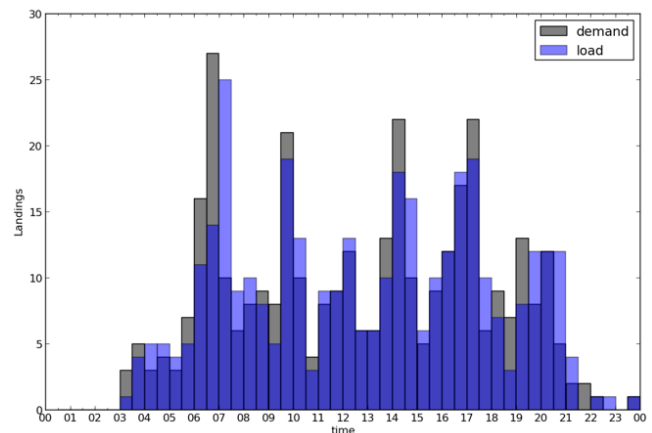

Figure 7 Traffic demand (grey) and load (light blue – semi-transparent) for short (1.5 hour) LVP event during morning traffic peak. LVP state and runway-in-use are shown above the traffic bars.

For both LVP events multiple simulations were carried out to evaluate the four entries of the cost matrix (Figure 3), i.e. combinations of event forecasted/not forecasted and event occurred/not occurred.

The results for selected KPIs are shown in Table 3 for the short LVP event and Table 4 for the long LVP event.

The KPIs given in the tables are:

- Trackmiles / flight: nautical miles flown from end of STAR to touchdown. Measure for environmental impact/flight efficiency and cost-effectiveness.
- Holding time and holding time per flight: minutes spent in holding pattern by arriving aircrafts. Measure for environmental impact/flight efficiency and cost-effectiveness.

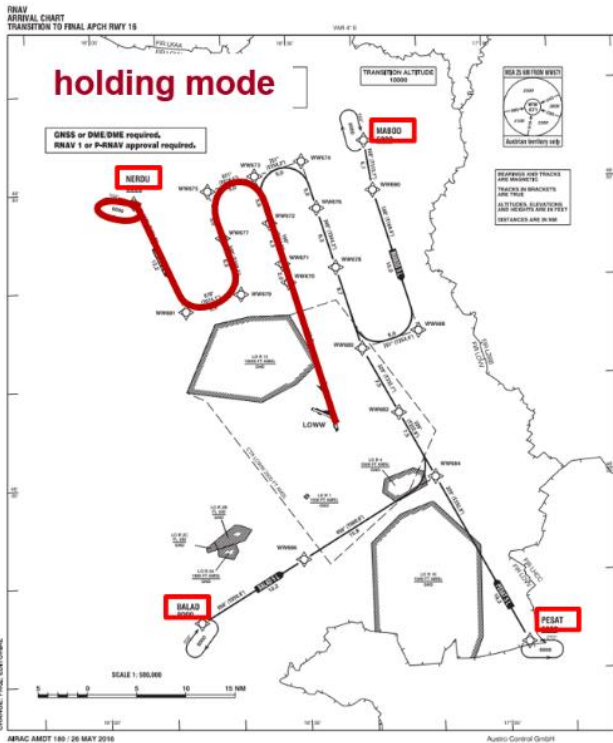

Figure 5c As Figure 5a but for holding mode (red).

For the various weather situations considered (low visibility procedures, thunderstorms in approach sectors, ...) the validation of simulator against actual flight trajectories is performed to make sure the results from the simulator are a realistic representation of the traffic pattern, which is a prerequisite to base further evaluation on the simulator output. The validation results show that real and simulated flights behave similar and furthermore, that slightly different flight paths of individual flights do not damage the overall flight pattern (see Figure 6). This conclusion was also confirmed by air traffic controllers, who did a qualitative analysis of the simulator results.



Figure 6 Snapshot of simulated (blue) to real (yellow) traffic comparison.

Based on these validation experiments it is considered to be reasonable to use the simulator for performing weather impact analyses.

- Delay and delay per flight: minutes flights are delayed on ground at origin by air traffic regulations. Measure for capacity and cost-effectiveness.
- ATCO phrases: number of radio-communication transactions given by air traffic controllers. Measure for traffic complexity.

For the short event the results of the four scenarios are very similar and partly unexpected. The best results, except for delays, occur for the scenario with well forecasted LVP (h). The expectation would be that trackmiles and holding time are better for the false alarm case (f), where traffic is regulated because of LVP forecast but no LVP occurs, meaning higher airport capacity than in the h case. This effect can be explained by the underlying ATM measures, where traffic is regulated to 30 arrivals per hour if LVP is forecasted and further regulated once LVP really occurs. This results in a traffic peak at the end of the forecasted LVP period in the f case, which is smoothed out by the additional regulations applied in the h case once LVP sets in. The very similar results suggest, that for a short LVP event the best strategy is to apply no traffic regulation, but accept some holding time during the LVP period.

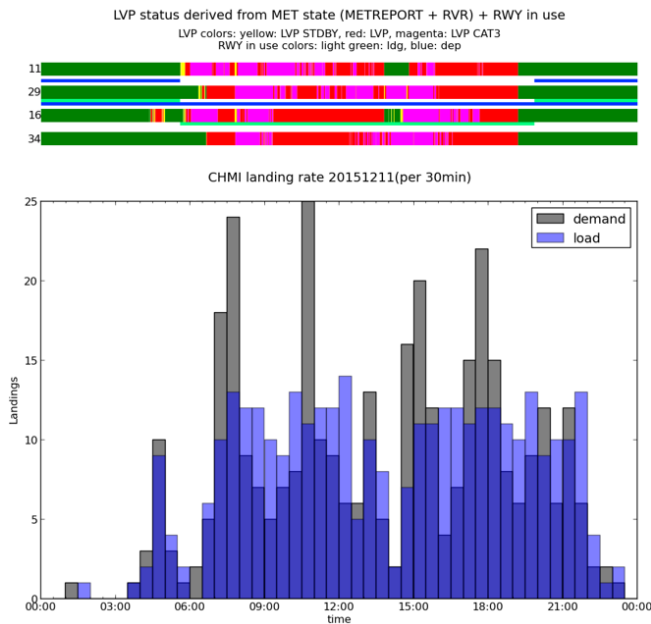

Figure 8 As Figure 7 but for long (13 hour) LVP event.

Table 3 KPIs derived from simulations of the short LVP event (1.5 hours, 103 arrivals)

	n	f	m	h
Trackmiles / flight	60.1	59.5	59.8	58.8
Holding time [min]	8	10	6	4
Holding time / flight	0.08	0.10	0.06	0.04
Delay [min]	0	175	215	187
Delay / flight	0	1.7	2.1	1.8

ATCO phrases 1069 1074 1069 1065

For the long LVP event the false alarm case (f) shows the best results for all parameters except delay. Due to the applied traffic regulations and weather restrictions not occurring, the traffic is better distributed over time. The case where LVP occurs but was not forecasted (m) shows the worst results, except for delays. In this case the traffic peaks combined with the LVP related capacity restrictions cause significant holding time and high air traffic controller workload (ATCO phrases).

The case with well forecasted LVP (h) shows the largest delays, as traffic regulation can be applied based on the forecast more efficiently. The so obtained better match of traffic load and available capacity results in acceptable values for the other KPIs.

In summary, for long LVP events good forecasts are very valuable as flight efficiency and controller workload can be kept on acceptable levels.

Table 4 KPIs derived from simulations of the long LVP event (13 hours, 314 arrivals)

	n	f	m	h
Trackmiles / flight	62.4	60.8	69.2	65.4
Holding time [min]	52	18	327	94
Holding time / flight	0.17	0.06	1.04	0.30
Delay [min]	0	899	3744	5594
Delay / flight	0	2.9	11.9	17.9
ATCO phrases	3159	3076	3515	3236

CONCLUSION

Weather forecasts are a valuable input for ATM planning and situational awareness. In order to evaluate the actual value and identify potentials to improve weather forecasts and their application in ATM, an evaluation method based on KPIs derived from air traffic simulations was developed. Validation experiments comparing simulated flight tracks to real flight tracks from air traffic surveillance radar, as well as qualitative assessment by air traffic controllers, showed that the air traffic simulator can realistically reproduce traffic patterns and hence it can be used to evaluate various combinations of traffic and weather events.

First results for LVP already gave better insight into the interconnection of weather forecasts, applied ATM measures and resulting ATM performance. This will ultimately enable to provide better weather forecasts tailored to ATM needs as well as better integration into ATM procedures to increase air traffic efficiency and safety.

Next steps will be to extend the evaluation to other weather events, e.g. thunderstorms in the approach sectors, and to further improve the evaluation method to better reflect different stake holder's requirements and needs. This will include improved KPIs, in-depth analysis of temporal variations in KPIs during the simulation and a refined weighting and combination of KPIs for the cost matrix.

REFERENCES

- [1] Austro Control (2016). AIP AUSTRIA. <http://eaip.austrocontrol.at/>
- [2] De Reyck, B., Degraeve, Z. and Grushka-Cokayne, Y., (2006). Decision Support Using Performance Driven Trade-Off Analysis. EEC Note: EEC/SEE/2006/001
- [3] Eurocontrol (2011). Measuring Operational ANS performance at Airports. Technical Note.
- [4] Eurocontrol (2015). "RECAT-EU" European Wake Turbulence Categorisation and Separation Minima on Approach and Departure. Edition 1.1.
- [5] ICAO (2009). Manual on Global Performance of the Air Navigation System. Doc. 9883.
- [6] ICAO (2016). Aircraft Type Designators. Doc. 8643. Edition No. 44.
- [7] Murphy, A.H. (1966). A note on the utility of probabilistic predictions and the probability score in the cost-loss ratio decision situation. *J. Appl. Meteorol.*, 5, pp. 534–537.
- [8] Richardson, D.S. (2000). Skill and relative economic value of the ECMWF Ensemble Prediction System. *Q. J. R. Meteorol. Soc.*, 126, pp. 649–668.

AUTHOR INFORMATION

Martin Steinheimer, Meteorology – Development & Innovation, Austro Control Gmbh, Austria. (Email: martin.steinheimer@austrocontrol.at)

Carl-Herbert Rokitansky, Head of Aerospace Research - Computer Sciences Institute, University of Salzburg, Austria. (Email: roki@cosy.sbg.ac.at)

GNSS FINAL APPROACH TRAJECTORY ANALYSIS FOR GENERAL AVIATION AIRCRAFT

Matija Sužnjević, mag. ing. aeronaut.

Department of Aeronautics, Faculty of Transport and Traffic Sciences, Croatia

matija.suznjevic@gmail.com

Petar Andrašić, mag. ing. aeronaut.

Department of Aeronautics, Faculty of Transport and Traffic Sciences, Croatia

petar.andrasi@fpz.hr

izv. prof. dr. sc. Doris Novak

Department of Aeronautics, Faculty of Transport and Traffic Sciences, Croatia

doris.novak@fpz.hr

Abstract - Standalone on-board GNSS systems used in general aviation are sufficiently accurate and precise to be used as part of instrument approach procedure. The number of standalone on-board GNSS systems on general aviation aircraft is increasing at high rate. Many of general aviation pilots use standalone on-board GNSS systems as a supplementary means of situational awareness when flying. Accuracy and precision of positioning of those systems are two critical elements for flight safety in final approach phase. Unlike the conventional ground based navigation systems such as ILS, VORs and NDBs, standalone GNSS receivers which are not integrated in aircraft avionics still need testing in order to prove their applicability for general aviation under IFR conditions. Aircraft trajectory was analyzed during final approach phase of flight in terms of accuracy and precision in order to determine the horizontal and vertical deviations from ideal approach path. Trajectory analysis proved that standalone on-board GNSS systems used in general aviation are accurate and precise enough to be safely used as part of instrument approach procedure.

Key words - general aviation, trajectory analysis, satellite navigation

INTRODUCTION

With predicted annual growth of air traffic by 2% [1] and rapid growth of general business aviation (68% more Worldwide Business Aircraft Operators in period from 2000 to 2015 [2]) sky is getting highly congested. To ensure safe conduct of air traffic European Aviation Safety Agency has issued Notice of Proposed Amendment which states

conditions regarding implementation of Performance Based Navigation with December 2018 as final deadline for implementation [3]. There are many advantages of implementing such procedures. Final approach segments can be curved paths, there is no need for installing costly ground equipment and approach paths can be shortened, therefore reducing costs and fuel consumption.

This paper is based on the assumption that standalone on-board GNSS systems used in general aviation are sufficiently accurate and precise to be used as part of instrument approach procedure. To test this, a series of data collection have been conducted, both on ground and on-board aircraft flying approach procedure.

With the cancelation of GNSS Selective Availability in 2000 GNSS systems became suitable for civilian applications, such as air navigation. Also, implementation of augmentation systems improved already high accuracy as well as reliability and integrity monitoring. Three augmentation systems are in use today; space based (SBAS), ground based (GBAS) and air based (ABAS) systems [4]. During data collection, European space based augmentation system EGNOS was in active use.

It is important to highlight the difference between precision and accuracy regarding GNSS systems. Figure 1 shows the relationship between precision and accuracy. Dashed vertical line indicates the mean of the dataset (the inflection point at

which the histogram balances). Red arrows bracket the spread of the dataset at one standard deviation from the mean (precision), while the black arrows bracket the offset of the mean from truth (accuracy). Accuracy is the difference between the true and expected value.

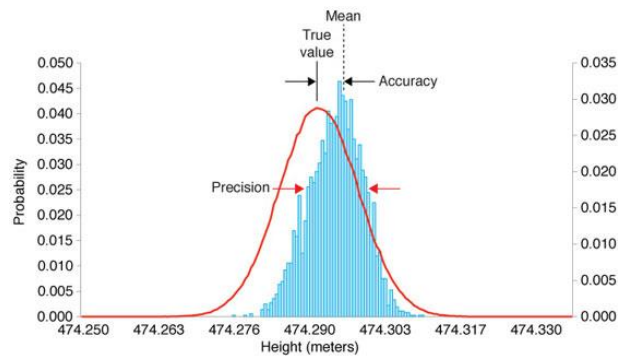

Figure 1 – Relationship between precision and accuracy. [4].

Accuracy can be evaluated in two ways: by using information internal to the data, and by using information external to the data. External accuracy is when a standard, another instrument, or some other reference system is brought to bear to gauge accuracy. [4].

For the purpose of the testing, an Instrument Landing System (ILS) was used as external reference, with the assumption that the flight was conducted perfectly following the ILS path.

STATIC DATA COLLECTION

Data collection was done in two stages: static data collection and inflight data collection. First part of analysis was based on static data gathered by GPS receivers mounted on the car roof while the car was parked on an open area to minimize interference. Static data collection phase lasted for 30 minutes, and the GPS data was recorded on a laptop in the form of NMEA 0183 sentences. Program used for recoding data was VisualGPS. Objective of static data collection was to establish the initial system state of the GPS receiver, define possible differences and errors and acquire information of system in static conditions.

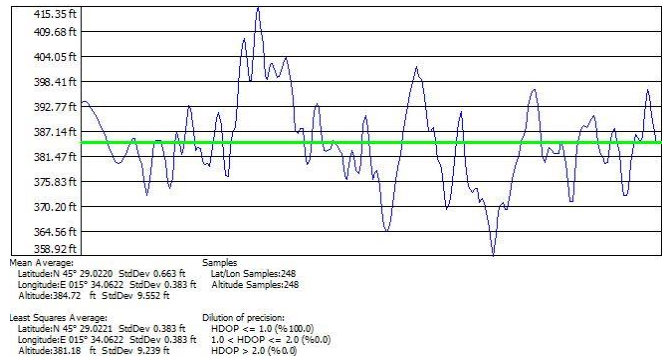

Figure 2 – Altitude measurement in static conditions

Average altitude recorded was 384 [ft] with standard deviation 9.552 [ft]. Figure 3 shows the characteristics of the GPS altitude signal which will form normal distribution after enough recorded samples (as stated by Langley around 12 hours [4]). Mean altitude is shown with a green line, while the blue line represents actual measurement. Note that during data collection vehicle was stationary, and altitude did not change. In contrast the GPS altitude is significantly wondering from the mean altitude. As showed by figure 3 deviations from mean can be separated in two sets of oscillations – high frequency oscillations and low frequency oscillations. High frequency oscillations are errors caused by thermal noise within the receiver while low frequency oscillations are errors caused by satellite position and the quasi-random effect of multipath. [4].

INFLIGHT DATA COLLECTION

Inflight data collection was conducted on Cessna 172N aircraft which is equipped with minimum equipment needed for conducting flight under Instrument Flight Rules (IFR) conditions. The data collection was carried out on segment of approach path for runway 05, Zagreb International Airport which starts from the starting point of approach (8.3 [NM] IZA DME) to a decision height (DH) distance 0.7 [NM] according to IZA DME. As seen from Figure 2 starting point of approach (point of ILS signal interception) is at altitude 3000 [ft] and decision altitude is 553 [ft]. Altitude at outer marker is 1550 [ft], and the final approach course is 044 degrees.

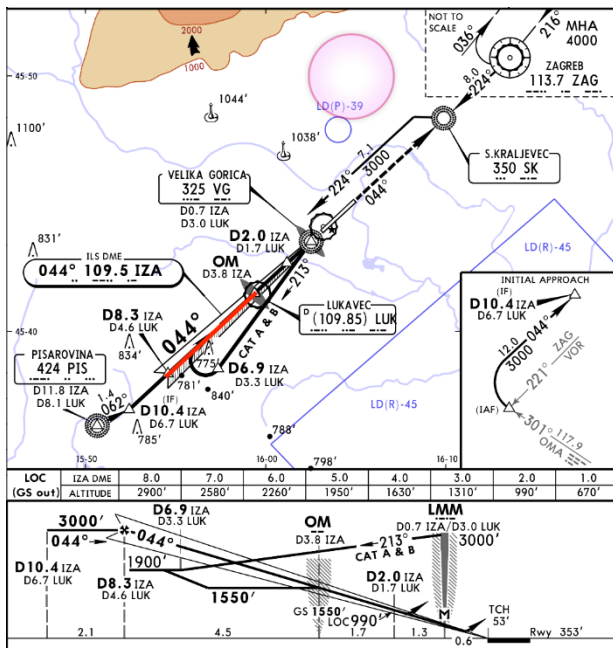

Figure 3 – Approach segment studied for GNSS accuracy [5].

The data collection was carried out following ILS approach path, i.e. the ILS path was used as a fixed reference in space. Data was recorded using Garmin GPSmap 76CS connected to VisualGPS, Garmin GPSmap196 and Apple iPad.

Dashboard was filmed via video camera for later comparison between recorded track and ILS indicator deviation. According to course deviation indicator trajectory didn't deviate from ILS path and is to be assumed perfect (without off-track deviation) ruling out pilot error.

To comply with Required Navigation Performance requirements GPS RNAV approach trajectory must be within required minimums for RNP 0.1. Which means that off-track deviation in lateral plain is within 0.1 [NM] from projected track in 95% of time. Vertical guidance must be conducted with barometric altimeter, which makes GNSS approach a non-precision approach.

DATA ANALYSIS

During both data collection stages EGNOS function was enabled on all devices, data was recorded on a laptop in a form of NMEA sentences using VisualGPS program. Figure 4 shows one print-out of the approach track (horizontal and vertical).

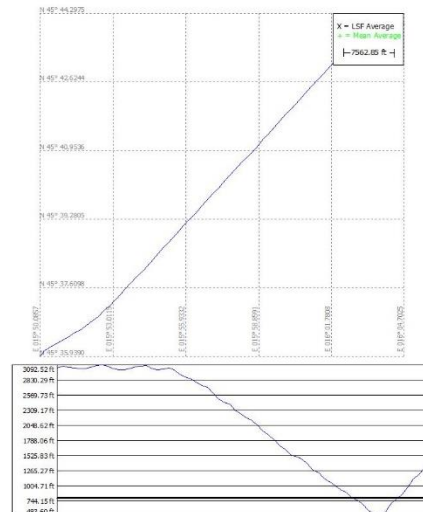

Figure 4 – Recorded final approach trajectory

Collected data was analyzed by comparing recorded trajectory with projected one. Projected trajectory was created by generating an overlaying on already known ILS locator path. Initial approach fix was used for the initial point of projected trajectory while the end point was OM (as shown on Figure 3). These two points form a straight line and represent an ideal approach path which was assumed to be flown. Second set of points was extracted from collected GPS data. Distance between points generated during data collection and ones created in ideal approach trajectory represent horizontal deviation from ideal flight path. Distance between two points was calculated using simplified formula (1):

$$d = \text{acos}(\sin \phi_1 \sin \phi_2 + \cos \phi_1 \cos \phi_2 \cos \Delta\lambda) R \quad (1)$$

This method was earlier described as external accuracy evaluation, since the external reference was used to calculate accuracy.

As mentioned earlier, for non-precision approach, vertical guidance is provided by barometric altimeter. Since flight was conducted on ILS approach path ILS glide slope will be used as reference for creating projected trajectory. Projected trajectory in vertical plain will be compared to GPS data applying same principles as it was done for horizontal plain. Reference flight path was calculated using known published points. In this case, the initial altitude 3000 [ft], and final altitude at OM is 1550 [ft].

RESULTS

Table 1 – Results analysis for GPS accuracy - horizontal

	Results
Average deviation	0.02NM
Standard deviation	0.01NM
RNP.01 probability (% of results within 0.1 NM)	100%
Deviation width for 95% probability	0.0222NM

From the Table 1, it is clear that the accuracy of recorded trajectory well exceed the requirement from RNP 0.1 (100% of all points are within 0.1 [NM] of-track). For this set of data, 95% of all measured positions are within 0.0222NM from projected track, which is significantly better than required.

Table 2 – Results analysis for GPS accuracy - vertical

	1. approach	2. approach
Average deviation	51.17 [ft]	25.04 [ft]
Marginal deviation	32.59 [ft]	21.43 [ft]
100 ft probability (% of results within 100 ft)	99.992%	100%
Deviation width for 95% probability	57 [ft]	38 [ft]

Table 2 provides information on marginal deviation and average deviation. Currently there is no defined standard for minimum vertical deviation from desired altitude for GNSS devices because these devices cannot be used for vertical guidance. For the purpose of this paper a marginal deviation width of 100 [ft] was used at maximum acceptable deviation. For all performed approaches almost all recorded points were within those margins (maximum measured deviation is 109 [ft] in the first measurement). In two approach trajectories with highest vertical deviations first trajectory had 95% of all recorded points within ± 57 [ft] from the ideal approach path while in the second approach, 95% of all results are within ± 38 [ft].

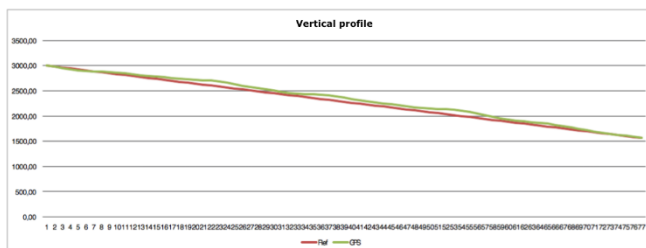

Figure 5 – Vertical approach profile

CONCLUSION

This paper is proves that standalone on-board GNSS systems used in general aviation are sufficiently accurate and precise to be used as part of instrument approach procedure for horizontal guidance. A selection of available off-the-shelf devices was used and tested in flight. Conventional instrument approach systems were used for computation of reference trajectory and inflight guidance. Recorded GPS data was than compared to generated reference trajectory for determining precision and accuracy of standalone on-board GNSS systems.

Analysis of collected data proved that horizontal accuracy is sufficient for inflight application and even exceeds the expectation. This confirms that available standalone on-board GNSS systems are accurate enough to be used as part of instrument approach procedure.

Analysis of vertical accuracy shows that current standalone on-board GNSS systems are not accurate enough to be used in vertical guidance. Next stage in research is to calculate vertical accuracy based on 2-dot glide slope deflection (margins becoming smaller as aircraft approaches to threshold) and repeating data collecting with addition of standalone barometric altimeter.

Based on the carried analysis and data available it can be confirmed that standalone on-board GNSS systems used in general aviation are sufficiently accurate and precise to be used as part of instrument approach procedure in horizontal plane, and that it is plausible to be used for vertical guidance, but further research is required.

REFERENCES

- [1] EUROCONTROL, "EUROCONTROL SEVEN-YEAR FORECAST FEBRUARY 2016" Flight Movements and Service Units 2016-2022, 15/12/17-52, 11.03.2016.
- [2] General Aviation Manufacturers Association, "2015 General Aviation Statistical Databook & 2016 Industry Outlook", 29.03.2016.
- [3] European Aviation Safety Agency, "Performance-Based Navigation (PBN) implementation in the European Air Traffic Management Network (EATMN)", Notice of Proposed Amendment 2015-01, RMT.0639 19. 01. 2015.
- [4] Langley, B, R, "Innovation: Accuracy versus Precision," GPS World, May 1, 2010.
- [5] Jeppesen, "ILS approach chart for Zagreb airport" Jeppesen electronic Flight Deck, 2016.

AUTHOR INFORMATION

Matija Sužnjević, Student, Department of Aeronautics, Faculty of Transport and Traffic Sciences, Zagreb. After graduation in Mathematical high school in Karlovac Matija started studying Aeronautics at Faculty of Transport and

Traffic Sciences in Zagreb. His final paper is being prepared also on the subject similar to the one in this paper. Apart from being a student, he has commercial pilot license (CPL) with Instrument Rating and Flight Instructor rating.

Petar Andraši, PhD Student, Department of Aeronautics, Faculty of Transport and Traffic Sciences, Zagreb. Petar Andraši was born in Zagreb on 2nd January 1990. He finished Aircraft Technician High School of Rudolf Perešin in Zagreb, Croatia in 2008. After high school he enrolled at Faculty of Transport and Traffic Sciences in Zagreb, Croatia where he studied on the field of aeronautics and finished bachelors programme at 2012 and masters programme at 2014. He is currently employed at Department of Aeronautic at Faculty of Transport and Traffic Sciences as teaching assistant.

Doris Novak, PhD. was born in Zagreb, Croatia in 1971. He graduated at the Department of Aeronautics at the Zagreb University. He was team leader in several research and technical projects in cooperation with Croatian national airliner and Air Navigation Service Provider. His work is focused on Performance Based Navigation concept development, which includes aircraft trajectory predictions (4D business trajectory), aircraft track keeping accuracy in specially designed airspace, airspace concept development, navigation and aircraft operations procedures design and usage of specially designed navigation specifications and applications. Since 2005, he is affiliate member of The Royal Institute of Navigation from London, a member of supervisory board of Croatian Chamber of Traffic and Transport Technologies, and presently, associate professor and Head of Aeronautical Division at the Faculty of Traffic and Transport Sciences in Zagreb, Croatia. He is also professional pilot and flight instructor.

IMPLEMENTATION OF OBSTACLE COLLISION AVOIDANCE SYSTEM INTO HEMS

Ing. Filip Škultěty, PhD.

Air Transport Department, University of Žilina
skultety@fpedas.uniza.sk

Ing. Martin Hromádka, PhD.

Air Transport Department, University of Žilina
skultety@fpedas.uniza.sk

Bc. Adam Líněk

Air Transport Department, University of Žilina
linekada@gmail.com

Abstract – this paper deals with the implementation of obstacle collision avoidance system in Helicopter emergency medical service (HEMS). Purpose of the paper is to analyse current equipment, which could help crews to avoid collision with wires, terrain and other obstacles. Today, HEMS operators use plenty of different systems. In this paper, authors unify the HEMS equipment, and also give recommendations to HEMS operators with selection of systems aiding to avoid collision during low-level flights and primarily systems, which are searching for obstacles, as wires, cableways, terrain, or any other obstacles, interfering with flightpath.

Key words – HEMS, Helicopter emergency medical service, GINA HEMS, Wire-strike, Flight safety, Low-level flights,

INTRODUCTION

Emergency medical service helicopters save thousand lives daily, all around the world. Helicopter Emergency Medical Service (HEMS) crews are the best trained, working with latest technologies. Even though, from time to time an accident may occur. In the United States of America, working at HEMS services is ranked in top ten of most dangerous jobs in the USA.

In the early 20th century, when anyone was in need of medical help, he had to call for doctor and if he was in luck, the doctor came in half a day, in a bad weather he may not come until many days. Today, medical care is much faster, thanks to, „Those Magnificent Men in Their Flying machines”. These men are doing very hard work, when they are trying to help in very dangerous condition. When the weather is poor, they still try to take-off and go into mission.

When the weather is poor; the main risk consists of obstacle collision or controlled flight in terrain (CFIT).

In the Czech Republic instrument equipment in Helicopter emergency medical service (HEMS) helicopters is customized for flights according to visual flight rules. Indeed, the purpose of HEMS missions cannot enable perfect and detailed prediction of enroute meteorological conditions, not even precise flight planning, therefore sometimes flight into instrument meteorological condition (IMC), or flights on edge between visual meteorological conditions (VMC) and instrument meteorological conditions (IMC) can occur. When flying in order to save someone’s live, the crew is under extreme pressure. This pressure may lead to their distraction.

When flying in verging conditions, during low-altitude flight in unknown environment, the risk of collision with terrain or obstacles is more likely to happen.

The most usual accident reason in HEMS traffic in 2008, 77%, was collision with obstacles, wires and controlled flight in terrain. (Blumen, 2009)

DEFINITION OF HEMS FLIGHT

HEMS flight means a flight by a helicopter operating under a HEMS approval, the purpose of which is to facilitate emergency medical assistance, where immediate and rapid transportation is essential, by carrying:

- a) medical personee;
 - b) medical supplies (equipment, blood, organs, drugs);
- or

- c) ill or injured persons and other persons directly involved;” (EASA, 2012)

CLASSIFICATION OF MEDICAL FLIGHTS USED TO MEASURE SERIOUSNESS OF A MISSION

Primary flights

- According to European Union Safety Authority (EASA): AIR OPS Regulation (EU) 965/2012 on air operations Annex V – Part-SPA SPA.HEMS, these primary flights are marked as HEMS flight.

- H1 - Flights to unknown places, with no members of emergency services at the scene. When taking off to primary mission, pilot knows only heading to accident and does not know the landing place concretely. Helicopter in this type of mission is landing into terrain as close to accident scene as possible. By the crew own discretion.

- H1 - Flights on request of rescue services on an accident scene.

Secondary flights

- According to EASA: AIR OPS Regulation (EU) 965/2012 on air operations Annex V – Part-SPA SPA.HEMS, these primary flights are marked as Air Ambulance flight “In regulatory terms, air ambulance is considered to be a normal transport task where the risk is no higher than for operations to the full OPS.CAT and Part-ORO compliance. This is not intended to contradict/complement medical terminology but is simply a statement of policy; none of the risk elements of HEMS should be extant and therefore none of the additional requirements of HEMS need be applied.” (EASA, 2012)

- H2 – Immediate secondary flight – flight being conducted from HEMS base to known, described places, such as hospital helipads in order to transport patient to another medical care centre, which is more suitable for the patient.

- A – Secondary flight – scheduled transport of patients to higher medical care centre.

Other flights

- H1 – Need for helicopter for any other reasons such as transporting medical material, co-operation trainings, floods, technical rescue etc.

CURRENT EQUIPMENT USED IN HEMS HELICOPTERS

Currently, HEMS helicopters are equipped for flights, according to VFR rules and are equipped with noncertified

(certification out of date) IFR instruments. Here listed equipment stays for Eurocopter EC135T2. Some of the other helicopters are equipped similarly, but the main instruments are inbuilt in glass cockpit:

- Garmin GNS 430
- Horizontal situation indicator (fully ILS capable)
- Altimeter
- VSI
- Airspeed indicator
- Radar altimeter
- Attitude indicator
- iPad equipped with GINA HEMS app in combination with AirNAVpro



Figure 1 – Instrument panel of EC135 OK-DSD

AVAILABLE COMPLEX COLLISION AVOIDANCE SYSTEM

GINA HEMS

GINA HEMS is an application for iPad, which was developed by a Czech company GINA. It is currently used by Czech HEMS operators – DSA and Alfa Helicopter. iPad is connected with a dispatching via Groupe Spécial Mobile (GSM) network, which allows good coverage in the Czech Republic. The main purpose of GINA HEMS is providing information to helicopter crew about accident site, injured person and many other details describing the purpose of their mission.

GINA HEMS is linked to an application – AirNAVpro, which is used for non-precision navigation based on iPad’s Global Positioning System (GPS) module. AirNAVpro is equipped with terrain data, providing terrain alerts. ICAO map in AirNAVpro shows all the features of airspace such as: special activity airspaces, restricted and dangerous areas, airports, heliports (including medical centre helipads) and can download actual notice to airman (NOTAM), message d’observation météorologique régulière pour l’aviation

(METAR), terminal aerodrome forecast (TAF) etc. AirNAVpro can also show frequency of local airspace air traffic control and also local airports frequencies. AirNAVpro as a feature which is included in GINA HEMS is usually used during cruise level flight and can be helpful in low visibility conditions to warn against upcoming terrain.

GINA HEMS app is equipped with map layers consisting of: classical road map, ortophoto map, tourist map (tourist paths, known places, ski-slopes etc.), map of Czech fire brigade (with exact postcodes, helping crew to determine the accident scene), terrain map and actual weather data (precipitation meteoradar). The iPad is placed on the middle panel in holder and is possible for TCM to pick up the iPad and check the data shown.

When the crew receives a call on e.g. primary mission, the data such as – position of the accident site, details such as heading and distance are available immediately in GINA, so the pilot (or TCM) can specify the exact position of the accident (with his local environment knowledge). When a pilot is starting up the helicopter and is waiting for instruments values, he has time to check flight track and intended landing spot for possible obstacles. When approaching to intended landing spot TCM can uptake the iPad and look closely for any obstacles, or in case of low visibility for terrain and may instruct PIC to avoid them.

GINA HEMS is also equipped with tourist maps, that include wire data, but these data are unreliable and they consist only high voltage electricity.



Figure 3 – iPad equipped with GINA HEMS placed in EC135 of DSA

ADDING A NEW MAP LAYER CONTAINING WIRES INTO GINA HEMS

As discussed with HEMS pilots, we decided to add a new map layer, which should consist of wire data, such as height of power pole, voltage (thickness of the wire) and exact coordinates containing X, Y and Z coordinate.

Main requirements of pilots were:

- Height of power pole
- Thickness of a wire
- Exact coordinates

Requirements on data quality to be able of adding into map underlay, to be able to set a warning function:

- Data in electronic version – shapefile format
- Coordinates in Křovák conic projection or be able to convert into Křovák

We contacted administrator of powerlines databases, mr. Pavel Špryňar from Czech company - „ČEZ distribuce – Východní čechy“. We were provided with a sample map detail of city Neděliště. Data are in satisfactory geographic quality, but constructions older than 10 years are not containing height of pylons, so we are currently cooperating with other companies that could provide us with data of wires.

We also contacted administrators of Geographical Information System (GIS) Emergency services of Czech Republic, in order to provide us with data of wires and obstacles, that are containing wire X and Y coordinates, but unfortunately they denied our request because of a license reasons, that the use of GIS Emergency services (IZS ČR) data is limited only for Emergency services and not possible to provide these data for private operators of HEMS, such as DSA or Alfa Helicopter. We also contacted administrators of Czech cadastre data and asked them about providing us with data of wires. Administrators are not able to export these data in shapefile format, because older map underlays are only data of paper maps scanned into electronic version.

The big disadvantage of these databases data is outdated of the database. When any database is issued it becomes nonactual with the date of edition, which makes the database not that reliable source and the crew needs to take consideration of that. On other databases, for example navigation databases are updated every 28 days, which should keep the data current and safe to be used. The other big disadvantage of adding a new layer into GINA, could be pilot dependence on wire data, which could lead to more risky decisions regarding flying in marginal weather conditions. PIC may rely on data from GINA, which could be non-actual and this could lead to dangerous decisions. Current procedures and equipment tempts crew to rely on noncertified instruments (such as GINA HEMS), which may lead to deliberate violations of VFR requirements on visibility and flying into known IMC conditions.

POSSIBLE WAYS OF OBSTACLES DISPLAY

By our discretion and discussion with HEMS pilots, the best way of wire and terrain warning may be HUD projection showing and highlighting terrain, obstacle and wire warnings. Pilots experienced in HEMS explained us that when the weather conditions are poor, crew needs to look outside the helicopter and cannot fix the eyesight in the dashboard, and on top of that, they also explained us, if a helicopter is in any critical phase of flight (hovering, low-speed etc.) and pilot looks into instruments, inadvertently he starts to drive the helicopter in the direction he is looking. Based on this reasoning we agreed that the best way to show warnings would be HUD display projection in front of PIC above dashboard or as a Helmet-mounted display (HMD) and also voice warnings that would sound until certain groundspeed (muted when clear of conflicts). Example of warning is illustrated in Figure 5: HUD projection of WIRES AHEAD warning.

When in low groundspeed (hovering), the voice warning should be given in any direction, providing the crew with distance and course to obstacle such as - „Wires ahead, 1000ft”, with HUD projection saying - „WIRES AHEAD”. We also advice to add one more regime when using hoist, in which would be warning - „, WIRES UNDER”, on object that is under helicopter altitude and may not endanger the helicopter, pointing out obstacle that could hit with a underslung loads or external load sling.

Table 1. Comparison of obstacle databases

	ČEZ distribuce	GIS Emergency	Czech Cadastr	eTOD
Wires height	partly	no	no	X
Voltage	yes	no	no	X
Shapefile data	yes	yes	no	yes
Obstacle height	wires	no	no	<100m
Area coverage	100%	100%	100%	100%



Figure 4 – Ortophoto map of Nedeliště with marked 22kV electricity pylons and above-ground powerlines [Source: Google Earth with the application QGIS]



Figure 5 – HUD projection of WIRES AHEAD warning

ADDING ELECTRONIC TERRAIN AND OBSTACLE DATA (ETOD) DATABASE INTO GINA HEMS

Based on ICAO Annex 15, every member state is obligated to administer electronic terrain and obstacle data. In Czech Republic, eTOD database is administered by Czech air navigation services. eTOD database consists of two separate areas:

- Area 1 – representation of all man-made obstacles and natural significant features covering whole Czech Republic, higher than 100m AGL
- Area 2 – all of all man-made obstacles and natural significant features obstacles around the airport, that is able to receive IFR traffic, in radius of 45km higher than 60m
- DTED – digital terrain data representing the elevation of terrain at a number of discrete points, these data are controlled by Czech ministry of Defence and they denied to provide us with these terrain data

We contacted Ing. Marek Dočkal from Czech Air navigation services and he provided us with sample data of obstacles higher than 100m (1000 ft) - eTOD database (**Figure 6 – eTOD Area**). Adding this layer into GINA HEMS and setting up a warning that would warn the crew on an upcoming obstacle would be a benefit.

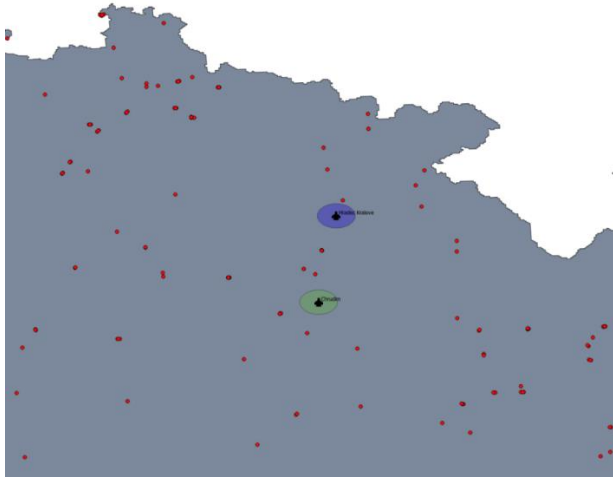

Figure 6 – eTOD Area [Source: eTOD database, lis.rlp.cz]

CONCLUSION

The goal of this paper was to summarize, recommend and possibly improve available systems that could provide safer HEMS service and finding systems, with those the HEMS would be more independent on weather conditions and offer more flexible service.

Current equipment of EC135 helicopters of DSA and Alfa Helicopters is sufficient for current HEMS procedures, but the crew does not have enough information about obstacles in flightpath. In low visibility conditions the crew may use database system AirNAVpro, but it is based on proximate terrain data, therefore these data are very unreliable and the GPS receiver is noncertified and also not very trustworthy, since it is only an iPad function.

When talking about GINA HEMS, we advise operators to equip the entire helicopter fleet with this system, because it facilitates mission. And we highly recommend all the operators to equip GINA HEMS with wire databases and

ETOD database. Unfortunately, these databases, we were offered to test are not equipped with electric pole Z-coordinate, so warning function would not be very suitable. It is necessary to instruct crews about GINA HEMS use and highlight that the system is not 100% reliable and all the obstacles may not be displayed. Also we need to point out, that electricity database operators do not have data of all the wires.

REFERENCES

- [1] Accident Investigation Board Norway, 2014. [Online] Available at: <http://www.aibn.no/Luftfart/Avgitte-rapporter/2015-06-eng?pid=SHT-Report-ReportFile&attach=1>
- [2] AGUILERA, C., 2015. EGNOS ADOPTION IN AVIATION. [Online] Available at: https://egnos-user-support.essp-sas.eu/new_egnos_ops/sites/default/files/workshop2015/EGNOS_adoption_aviation.pdf
- [3] BECKER, S., 2013. REGA. [Online] Available at: http://www.aeromedsocaustralasia.org/img.ashx?f=f&p=melbourne_2013%2FBECKER_Stefan.pdf
- [4] KANDERA, B., BADÁNIK, B., Zvyšovanie bezpečnosti všeobecného letectva s využitím mobilných protizrážkových systémov In: Horizonty dopravy. - ISSN 1210-0978. - Roč. 19, č. 3-4 (2011), s. 31-34.
- [5] BLUMEN, I., 2009. An Analysis of HEMS Accidents and Accident Rates. [Online] Available at: <http://www.nts.gov/news/events/Documents/NTSB-2009-8a-Blumen-revised-final-version.pdf>
- [6] Central Aviation Authority Czech Republic, 2013. [Online] Available at: <http://lis.rlp.cz/predpisy/predpisy/index.htm>
- [7] EASA, 2012. Easy Access Rules for Air Operations. [Online] Available at: <https://www.easa.europa.eu/document-library/technical-publications/easy-access-rules-air-operations>
- [8] EASA, 2015. Certification Specifications. [Online] Available at: <https://www.easa.europa.eu/system/files/dfu/CS-ETSO.pdf>

REMOTE TOWER SPECIFICATIONS IN DEPLOYABLE AIRBASES

Tímea Vas

Military Aviation department, National University of Public Service, Hungary

vas.timea@uni-nke.hu

Abstract - Remote tower technology results in unique solutions for the provision of Air Traffic Services. It's different configurations work in live operation in several European civilian aerodromes. In this paper author investigates the specifications of military application, finds out similarities and differences between civilian and military aerodrome operations, particularly the deployable ones. Deployable airbase operation also requires new solutions. It would be investigated what requirements and safety criteria are necessary for the adaptation of remote tower for the provision of Air Traffic Services at deployable airbase.

Key words – remote tower, deployable airbase, military specifications, air traffic control procedures, safety aspects

INTRODUCTION

Remote tower (below RTWR) is a unique technology that expands and supplements the provision of Aerodrome Traffic Control/ Flight Information Service, and also contributes to enhance the situational awareness, and rises the aviation safety aspects of ATCO¹⁸ /FISO¹⁹. The first aerodrome was the Swedish Örnköldsvik whose traffic was remotely controlled over 150 km far away from Söndsvall ATM²⁰ centre since 2014 in live operation. Since that time Germany, Austria, Great Britain and even the Hungarian ANSP²¹ have installed and started remote tower validation tests of the medium size aerodrome called Liszt Ferenc. The tools of RTWR's technological background nowadays is not considered incomparable, because it consists of cameras and data links developed by security companies. Nevertheless considered as pioneering solution for provision of ATS²²

because it should be completed with special requirements of controlling and monitoring all traffic movements over area of responsibility. Among requirements firstly should emphasize the two-way radio communication on the aerodrome published frequency. This radio channel is called by those aircraft flying in vicinity of aerodrome and it should be accessible for ATCO/FISO located in remote position. In order to remain the continuous two-way radio communication there are many solutions exist. First one regarded conventional, when the remote position is within the radio range. The radio transmission can be broadcasted via ground or air based relaying stations, it could be also transmitted by IT based and satellite based communication lines. Maintaining direct connection also necessary with neighbouring ATS units and aerodrome services. It can be provided on land line or mobile phone, on data link with electronic strips²³ or short messages and on radio contact.

Among requirements RTWR technology should provide identification of aircraft over area of aerodrome controller responsibility. The aerodrome controller generally uses direct visual observation for identification of traffic in the air and on the manoeuvring area of aerodrome, but in that case when ASR²⁴, or SMR²⁵ data are available, those also could be used for identification. The RTWR technology includes some additional options for aerodrome controller, with the presentation of integrated surveillance (originated from SSR²⁶, PSR²⁷; ADS-B²⁸) and flight data correlation on the real-time picture of the aerodrome. For the optimization of aerodrome controller's tasks for providing the efficient and orderly flow of traffic different applications and configurations can be visible on screen.

¹⁸ ATCO: Air Traffic Controller Office

¹⁹ FISO: Flight Information Service Officer

²⁰ ATM: Air Traffic Management

²¹ ANSP: Air Navigation Service Provider

²² ATS: Air Traffic Services

²³ Strip: Electronic or paper strip containing the data from one specific flight plan, used in air traffic control for the display of flight data on a display screen or flight progress board (Eurocontrol ATM lexicon)

²⁴ ASR: Aerodrome Surveillance Radar

²⁵ SMR: Surveillance Movement Radar

²⁶ SSR: Secondary Surveillance Radar

²⁷ PSR: Primary Surveillance Radar

²⁸ ADS_B: Automatic Dependent Surveillance and Broadcast

The RTWR of Hungarocontrol²⁹ uses A-SMGCS³⁰ and cameras two way integration, which dedicated to facilitate identification, tracking, flight plan data of traffic visualized in different coloured labels (see picture 1). Sensors those works as an integrated part of SMR, are able for detecting and tracing vehicles, personnel or animals on manoeuvring area. When LVP³¹ are in force due to reduced visibility conditions and at night times, the RTWR support aerodrome controller's decision making with highlighted margins, edges, II/III category-holding lines of taxiways and runways, in that case the real time visualization is improved by IR³² cameras (KTI VCF 2012)

(Dudás D 2012))



1.picture:integrated label of A-SMGCS data

In RTWR also necessary to provide functional panels for controlling lighting and navigation system on the aerodrome and a separated one for the presentation of meteorological data. According to recent experience the RTWR technology have been installed mainly at already established civilian aerodromes, so at the remaining part of paper I would like to investigate in one hand, whether how does the handling of military traffic procedures influence the RTWR applications. Other hand I would examine if any differences occur in RTWR installation when a new aerodrome established, particularly in operational environment of NDAB³³

PROCEDURES OF MILITARY TRAFFIC

Aerodromes, in a civilian and military terminology also means a defined area on land or water (including any building, installation and equipment) intended to be used either wholly or in part for the arrival, departure and surface movement of aircraft. However, the traffic of military aerodrome more complex, which resulted from different

types of aircraft, their different approaching speed and turbulence category and special flight procedures completed at aerodrome. In the text below the listed differences going to be examined and featured by related ATS procedures.

First of all, take into account approaching speed. Aircraft can be divided into categories from "A" to "E" which based on their approaching speed. Meanwhile the majority of traffic using civilian aerodrome are related to category "C" and "D", military traffic, like helicopters relate to "A" or "B" because their speed about 90-120 km/h and fighters are listed in category "E" with their 160/220 km/h.

Secondly should draw attention to differences of arrival procedures. However the military aerodromes are also equipped with the generally spread navigational systems, like VOR³⁴, DME³⁵, ILS³⁶ and only for military use applicable TACAN³⁷, but due to the specialities of military tasks the visual approach mainly practicable. The reason of few amount of IFR³⁸ traffic can be explained with standard IAS³⁹ and defined parameters which fixed for an instrumental departure or arrival procedure. Even in case of reduced visibility, when weather conditions drop below VMC⁴⁰, if possible pilots request to enter and leave CTR⁴¹ as SVFR⁴² flight. All traffic in CTR operating by VFR or SVFR are related to aerodrome controller area of responsibility.

(NATO Stanag 3297)

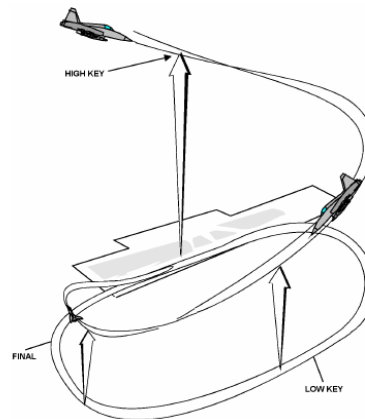

2.picture"Flame out procedure"

Flying by VFR make the pilots able for completing special military tasks connecting to aerodrome vicinity, and also contribute to the training and maintaining capabilities. First one should mention is the "high- low key" procedure, which associated with high approaching speed and dynamic flight

²⁹ Hungarocontrol: Hungarian ANSP

³⁰ A-SMGCS: Advanced Surface Movement Guidance and Control

³¹ LVP: Low Visibility Procedures

³² IR: Infrared technology

³³ NDAB: NATO Deployable Airbase

³⁴ VOR: Very High Frequency Omnidirectional Radio Range

³⁵ DME: Distance Measuring Equipment

³⁶ ILS: Instrument Landing System

³⁷ TACAN: Tactical Airborne Navigation

³⁸ IFR: Instrument Flight Rules

³⁹ IAS: Indicated Air Speed

⁴⁰ VMC: Visual Meteorological Conditions

⁴¹ CTR: Aerodrome Control Zone

⁴² SVFR: Special Visual Flight Rules

profile (see 2. picture) and they often use for simulating flame out. Same procedure for helicopters called single engine flight or autorotation, each one has different flight path and requires enhanced attention of aerodrome controller. We should not forget about NVD⁴³ procedures, including departure, landing and low level flight in CTR. The parachute dropping also can occur in military aerodromes and it does not require functional airspace, if it is involved in local regulations. Last but not least ATS procedure cover flight of unmanned aircraft systems at military aerodrome.

Take into consideration the above mentioned specifications and examine them regard of related ATS procedures and from that point how the RTWR technology can enhance or contribute to these procedures. The matter of fact, procedures of aerodrome controller should not be different neither from conventional tower nor from RTWR the ATS is provided.

The aerodrome controllers *“shall keep a continuous watch on all flight operations on and in the vicinity of an aerodrome as well as vehicles and personnel on the manoeuvring area. Watch shall be maintained by visual observation, augmented in low visibility conditions by an ATS surveillance system when available”*(Doc 4444). *Surveillance by the aerodrome controller is normally done by visual means (eyesight) alone, mechanically through the use of binoculars to improve eyesight or electronically, through the use of radar or closed-circuit television.”*(Doc 9426)

The aerodrome controller issue clearances and traffic information to provide separation between aircraft with different approaching speed and turbulence category in vicinity of aerodrome, in landing, in climbing area and on ground. Decision making process based on the positions of aircraft, which can be reported by the pilot, or originated from SSR/PSR/ADS-B if ASR or SMR is installed on aerodrome. RTWR could support and enhance aerodrome controller capabilities with radar data and flight plan application, in a case when radar data are not applicable, additional binocular function and object detecting can help.

IFR arrivals after handover procedure get into area of aerodrome controller responsibility that case, identification and position of aircraft coordinated before by approach controller. Departing IFR traffic concerns same procedure. Both departing and arrival IFR require visual observation

and that case the integrated flight plane label also would be preferable.

Controlling the huge amount of VFR/SVFR flight and special military flights, providing separation or traffic information (depending on defined ATS airspace classification) can be challenging for aerodrome controller. Hereinafter I would investigate how the RTWR could contribute the safety of given ATS procedures.

The “high-low key” procedure goes together with high speed and dynamic flight profile, it takes short time and completes overhead, which results the traffic get out of window view (clutter area). The remote directional PTZ⁴⁴ camera can be capable for object detecting and following independently on the aircraft speed and manoeuvres. Object detection, identification, recognition are available by RTWR’s integrated radar and flight plan data label, tracking and drawn flight path. In case of absence radar data, object detection is provided by combined thermo IR cameras.

Continuous visual observation of traffic circuit necessary when VFR/SVFR flights are commonly occur at the aerodrome. According to my assumption for the visualization of aerodromes with busy traffic circuit the 360° (see 3. picture) or 180° OTW⁴⁵ would be preferable. Also should be take into account the neighbouring airspace’s ATS classification, where from VFR flights could appear without transponder equipment compulsory, that case the aerodrome controller relies only on position reports. After engagement of object detecting it could be also useful to label the traffic and filled it with AFIL information.

Among special military flights firstly the NVD procedures going to be examined. That case aerodrome controller procedures similar to the situation when LVP in force, excepting the fact that all lights of aerodrome and navigational lights of aircraft are switched off. The IR technology could support decision making and situational awareness to issue landing clearance, detect the presence of object, obstacle, personnel, FOD⁴⁶ or animal onat hot spots of manoeuvring area without prior permission.

(wsj.com 2016)

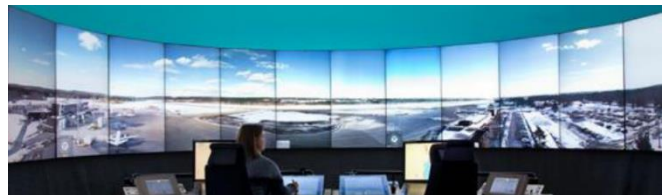

⁴³ NVD: Night Vision Device

⁴⁴ PTZ: pan-tilt-zoom camera

⁴⁵ OTW: ‘Out-the-window view’

⁴⁶ FOD: Foreign Ordnance Desposal

3. 360° OTW

Unmanned Aircraft's aerodrome operation usually regulated by national law and relating aerodrome controller procedures do so. Procedure generally involved communication, separation, detailed departing and arrival path, separated parking area and emergency procedures (Vas T., Fekete Cs 2013) (Palik 2013) For the safe handling of unmanned operations, RTWR could provide enhanced attention for sensitive areas and hot spots of the aerodrome and its vicinity. Unreported recreational flights can lead to unsafe situations however they are out, but close to CTR, ATZ⁴⁷. Traffic information about their presence could be useful for departing and arrival traffic of aerodrome. The application of FLARM (flarm pdf) signals, about location of glider, drones, hang gliders activity, to the RTWR's screen enabled the aerodrome controller's job.

NDAB- NATO DEPLOYABLE AIRBASE

The purpose of NDAB concept is to establish an aerodrome in remote places that under armed conflict or crisis response operation. The NDAB should be handling military and civilian traffic, IFR/VFR all weather operation, day and night, 24 hours 7 days of week. Services supporting aerodrome (airbase) operations are granted by multinational cooperation under umbrella of NATO "Pooling and Sharing"²⁷ initiative. The various components that make up the delivery of the DATM capability are contained within four capability modules: Wing Operations; Engineering/Runway Operations; Air Traffic Control; and Crash Fire and Rescue. The capability modules are sub-divided into 14 Service Teams (see 4. picture).

Leader nation's responsibility to provide rated personnel and technical equipment held in 28-day readiness⁴⁸ and after reaching of operation, continuous operation for 1 year long period (NATO ATMC 2015). In order to maintain the operational level of a service team, besides the leader nation, supporting nations also could participate with personnel and equipment. Each service team should apply their national regulations and related NATO Stanags in order to provide interoperability for personnel rating, technical equipment (hardware, software) and procedures. NDAB could be established at a bare area or abandoned aerodrome, but without any support of host nation. The bare airfield which sufficient to construct an aircraft operating strip and related manoeuvring area. Resulting from mentioned features, NDAB operational level requires mobile, quickly

deployable and install equipment and systems, that compatible with other systems and procedures of airbase.

(NATO ATMC 2015)

Capability Module	Service Team
Crash Fire and Rescue	Crash Fire and Rescue
Engineering/Runway Operations	Aerodrome Surfaces (runways, taxiways and aprons).
	Support and Maintenance Service (including reconstruction)
	Runway Lighting and Approach Lighting systems
	Ground Electrical Support (full power generation)
	Aircraft Arresting Systems
	Snow and Ice removal, de-icing and anti-Foreign Object Damage (FOD) operations
Wing Operations	Ground Handling/Cross-servicing
	Aerodrome Operations
	Aeronautical Information Services
	Flight Safety
	Meteorological Services
Air Traffic Control	Air Traffic Control (ATC) aerodrome, procedural approach and radar approach and precision services
	Navigation Aids
	Communication Services

4. NDAB service teams

In order to determine the optional application of RTWR support of NDAB, we should take into account the following details:

- type of ATS;
- airspace-related aspects (e.g. airspace classification, CTR, Aerodrome Traffic Zone (ATZ), Terminal Control Area (TMA), type of flight procedures);
- aerodrome layout complexity (e.g. number of Runways (RWYs), number of Taxiways (TWYs) and runway entrances, parallel or crossing runways, number and location of aprons);
- traffic characteristics (e.g. number of movements per day, number of pop up movements, type of traffic, aircraft fleet mix);
- environmental conditions at the aerodrome.

According to available experience, which relates to deployable operations around Afghanistan, following aspects should consider (AIP AFG 2016):

- ATCO/AFIS;
- Aerodrome airspace classification (OAMS CTR-Class D; OAUZ, OAZI ATZ F/G Class);
- 1 runway, 1-2 taxiways, apron for fixed and rotary wing aircraft;
- Environment dusty, desert, rocky, mountainous area with extreme weather conditions.

Before the investigation RTWR technology as optional tool for the provision of ATS on NDAB, read through the point of NATO ATMC⁴⁹:

⁴⁷ ATZ: Aerodrome Traffic Information Zone

⁴⁸ Readiness is defined as the length of time to reach the theatre of operations,

⁴⁹ NATO ATMC: NATO Air Traffic Management Cell

„The RTS concept may represent for the military a useful solution to support the provision of aerodrome services in geographical areas, or during deployable operations, when security reasons or contingency situations would not recommend, or allow, the physical presence of military operators. In this regard, a very sensitive aspect would be the consideration of System Vulnerability Requirements, in order to ensure the physical security of the system components, connection lines and the Integrity, Continuity and Availability of signals” (NATO RTS position 2015),

Real time visual presentation of deployable airbases from remote places, should meet system security requirements in order to guarantee the safe and orderly provision of ATS, site of communication, controlling aerodrome navigation and lighting system and OTW. Data quality, integrity and continuity should meet signal update requirements considering the flow of traffic, flight rules, related ATS provision and aerodrome complexity. The commonly used optical cable provide 100% reliability against wireless connections, however in military exists that widely spread remote technology which provide safe and secure controlling of RPAS50 via separated (secured) satellite communication radio lines. Next step is find out the mobile and deployable station for communication panels, cameras, controlling devices and electronic supply. The best configuration chosen considering the layout, provision of ATS service and characteristic of aircraft. The mobile container (see 5. picture), that can serve as RTWR technical background, should install in the geometrical centre, or other optimal point of layout not to affect safety areas of airbase operations.

(netvision 360)



5. mobile container for cameras

Listing the optional applications of mobile RTWR technology at deployable airbases we should take into account several solutions. It could serve as alternate or backup aerodrome tower of the conventional one, where from provision of ATS could be accessible in case of

external attack. Considering the model of European RTWR application, those deployable airbases where AFIS is provided, could be remote controlled from a regional aerodrome or ATM centre.

Safety (OFA 06.03.01.) solutions and procedures should engage when RTWR partly or completely out of service. First one when radio two-way communication operational, ATCO/FISO could engage LVP procedures and continue operation in a procedural way. Next, when RTWR completely out of service, those procedures should enforce, as in remote airfields of Alaska, where pilots entering via CRP51-s and reporting each turns, positions during approaching to the field. Using this procedure everyone who listened to the frequency has a picture about situation.

CONCLUSIONS

RTWR provide pioneering solutions for the provision of ATS for aerodrome operations, extending ATCO/FISO decision making and strengthen situational awareness. This paper investigate those solutions, which should emphasise in case of military operations, because it requires sometimes different handling and different ATS procedures. Using RTWR technology during deployable operations could be challenge to meet requirements of readiness deadlines, mobility, quick installation and providing secure line to prevent any jamming, interference.

REFERENCES

- [1] KTI VCF tanulmány :Kényszerhelyzeti torony kialakításának vizsgálata 2012 Budapest.,
- [2] Dezső Dudás: Hungarocontrol operational Concept of Remote Tower 2012-2014 Pdf
- [3] ICAO Doc 4444(Ed 15; 7.1.1.2);
- [4] ICAO Doc 9426 ATS Planning Manual 2.1.2.;
- [5] <http://www.wsj.com/articles/swedish-airport-to-have-traffic-controlled-remotely-1415035599>
- [6] Vas T, Fekete Cs: UAV az ellenőrzött repülőtér forgalmában, avagy egy szimuláció tapasztalatai; Repüléstudományi közlemények (1997-TŐL) (2) pp. 371-383. (2013)
- [7] Békési B, etc. Pilóta nélküli repülés profiknak és amatőröknek ISBN 978-963-08-6923-2 Ed.: Dr Palik Mátyás;2013
- [8] <https://flarm.com/technology/pdf>
- [9] AC/92-N(2015)0042; AIR TRAFFIC MANAGEMENT COMMITTEE / INTERIM AVIATION COMMITTEE (ATMC / I-AVC) Calling

⁵⁰ RPAS: Remote Piloted Aircraft Systems

⁵¹ CRP: Compulsory Reporting Points

Notice for NATO Deployable Airbase (NDAB) Rehearsal of Concept Exercise during TRIDENT JUNCTURE 2016

[10] AERONAUTICAL INFORMATION PUBLICATION REPUBLIC OF AFGHANISTAN Edition 77. Part 3 AD-06-01, 31. March 2016

[11] AIR TRAFFIC MANAGEMENT COMMITTEE (ATMC) Initial NATO Position on Remote Tower Services (RTS) concept; WORKING PAPER AC/92-WP(2015)0001 Silence Procedure ends: 24 Apr 2015 16:00

[12] www.netvision360group.com/product/netv-msu-6227-mil-military-surveillance-trailer/ (downloaded 2016.10.23)

[13] OFA06.03.01 Remote Tower – Safety Assessment Report for Single Remote Tower

AUTHOR INFORMATION

Tímea Vas, Assistant Lecturer, National University of Public Service Faculty of Military Science and Officer Training Institute of Military Aviation, Szolnok Hungary

MAJOR TRENDS IN THE RELATION AIRPORT – AIRLINERS IN THE CENTRAL AND EASTERN EUROPE

Prof. Sorin Eugen Zaharia

Faculty of Aerospace Engineering, University POLITEHNICA of Bucharest, Romania

sorin.zaharia@gmail.com

Abstract - After the liberalization of air transport in Europe in nineties years, the aviation market has changed, the European Union (EU) became a single aviation market, the airline-airport relationship has developed and the European airports now compete against each other to attract the services of airlines, especially to attract base aircraft and appear to do so vigorously for their business development. These new features of air transport market have had, over the last 12 years, a great influence on the development of airports in Europe, including also Central and Eastern Europe(CEE). In this paper, we present the results of our research using an external benchmarking approach focused on the air transport market, the competition of airports and the relationships between legacy and new low cost airliners and the main airports from across 8 countries in CEE. To the best of our knowledge this is the first analysis of this magnitude conducted over such a large domain in the airline industry in this region. The target group for this research is represented by the first 20 airports ranked from the connectivity criteria from 6 EU countries: Bulgaria, Croatia, Czech Republic, Hungary, Poland and Romania and 2 non EU countries: Republic of Moldova and Serbia. The analysis concerns the macroeconomic indicators of market and airport operational parameters: airport connectivity, passenger traffic, aircraft movements and also the strategy of airports in routes development. Some comparative remarks about the analyzed airports are made and some axes for a common airport-airliners strategy on the competitive and dynamic market of air transport are proposed.

Key words - airport development; Central and Eastern Europe; air transport market; airport competition, airport customers.

INTRODUCTION

The “Traffic report for December, Q4 and Full Year 2015” of ACI Europe [1] reveals that during 2015, passenger traffic at Europe’s airports grew by an average of 5.2%, approximately the same increase as in 2014 (5.4%). On EU airports, the average growth of passenger traffic was 5.6% with airports in Ireland, Portugal, Greece, Romania, Hungary, Slovakia, Slovenia and Lithuania achieving double-digit growth. Meanwhile, non-EU airports reported a growth of 3.9%.

In this very concurrently and complex air transport market, the airports strategy for the improvement of the relation with air company becomes essentially. For establishing this strategy, identifying the adequate targets (routes, airlines, timeframe) and for conceiving good implementation plans, the airports have to understand three things: their market, the competition and their customers. In this context, our paper presents a research on the market, the competition of airports and the airliners customers in the Central and Eastern Europe (CEE) in order to give a useful state of the art for designing the airport strategies for the next 15 years.

The target group of our analyze on airports – air companies relations development is represented by the top 20 airports ranked in terms of connectivity from 6 EU countries from CEE: Bulgaria, Croatia, Czech Republic, Hungary, Poland and Romania and from 2 non EU countries: the Republic of Moldova and Serbia. The surface area of the 6 EU member states analyzed represents 19.94% of the total EU area and the total surface of the 8 countries represents 9.94% of the surface of Europe. The interest for the present research on airport politics in CEE comes from the fact that the passenger air transport in the area has an important upward trend and still continues to have a big potential of development if airports and airliners will develop adequate politics for investments and routes geography. The total passenger traffic in the 8 analyzed countries had an important growth in the last years, the increase after the crisis, during 2009 – 2015 being by 53 % from 57.4 million to 87.8 million, and an important increase in airport connectivity was also recorded. This way, the aviation brings an important contribution to sustaining economic growth and the involvement of the countries above in the global economy.

UNDERSTAND YOUR MARKET

Airports need to understand and become specialized in their market. It is important to have a strong grasp on the market

they are serving as they cannot serve everyone. In this section we will analyze the evolution and the present level of indicators that airports need to quantify their market. Understanding the market starts with trying to quantify it. The airports have to make sure they understand the direct/indirect split and surface leakage. For quantifying the market, we analyze in this paper the aspects as hard and fast passenger traffic volumes and the airport connectivity. This will help segment the market and understand where the passengers will come from. The main economic and social indicators necessary for understanding the market are: GDP, forecast economic growth rates, economic ties, exports, foreign investments, population trends, corporate travel potential: how many people, how often and currently who with?; employment sectors: IT, pharmaceuticals, finance, automotive etc; main exports/imports: trading partners.

In what follows, we will analyze: the evolution of the GDP and of GDP per capita in the 8 countries of CEE. As the tourism indicator, we analyze the number of bed nights. Concerning tourism indicators, except for that analyzed in the paper, could be also taken in consideration: demographic concerning migration and visiting friend and family origin/nationality of visitors; source markets; unique leave patterns; events, festivals, places of interest which can be obtained from local tourism boards.

By analyzing the economic development of our countries target group, the evolution of GDP during 2004 – 2015 could be split in three different periods (fig 1): 2004 -2008 characterized by a significant growth of all analyzed countries, 2008 - 2009 with an important decrease as consequence of the peak of the economic crisis and 2010 – 2015, when in general, it was a positive trend, the countries having a continuous increase, with the exception of Croatia, which had a continuous decrease. The period of analysis was chosen from 2004 because this is the year when the first countries from Eastern Europe, from the former communist bloc, became member states of the European Union. In this situation there are Poland, Czech Republic and Hungary. For the entire period, the highest value of GDP is recorded by Poland, followed by the Czech Republic and Romania. Concerning the GDP per capita (fig. 2), the Czech Republic has the highest value, followed by Poland, Hungary and Croatia with very close values and similar evolutions.

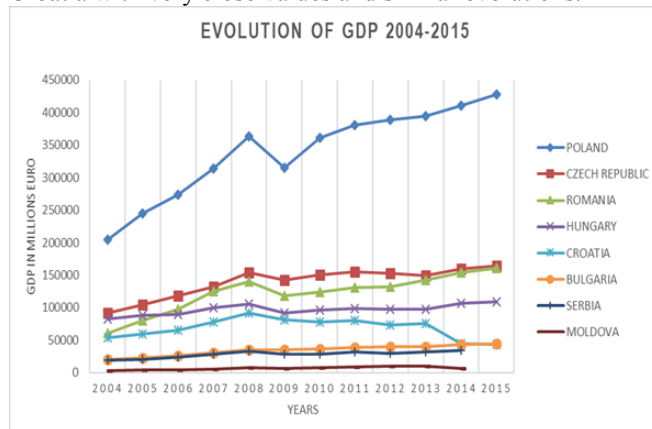

Fig 1 The GDP's evolution in Eastern and Central Europe (source Eurostat)

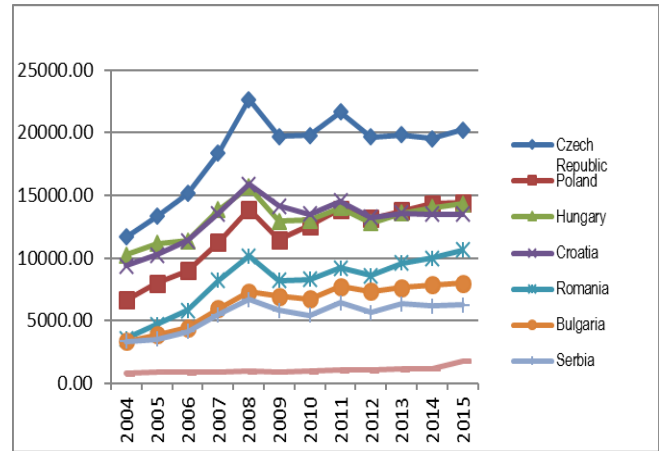

Fig 2 The GDP's per capita evolution in CEE (source Eurostat)

Generally, the evolution of GDP is linked with the evolution of passenger and cargo traffic and has a positive evolution moving forward, being very important in airport development. In particular, in the region, during the last 8 years of global financial crisis, the usual relation between GDP growth and passenger traffic performance has changed. In figure 3, we can see the evolution of passenger traffic in the 8 analyzed countries.

In the case of Poland, Romania and Bulgaria, both the GDP and the passenger traffic had the same trend showing important growths between 2008 and 2015; however, there are important differences between the values of the increase of GDP and of the passenger traffic (table 1). Furthermore, from the evolution of GDP per capita presented in Fig 3, it can be concluded that only Poland, Romania and Bulgaria arrive to record a higher value in 2015 than that of 2008, before the economic crisis.

In the case of Moldova, the growth of GDP and of the GDP per capita are very small in comparison with the growth of passenger traffic which is by 161.4%. If we correlate these evidences with the fact that the remittance in Moldova in 2012 was 24% of the GDP (ATAG, 2014), we can conclude that the important growth of traffic is the result of an important growth of workforce migration.

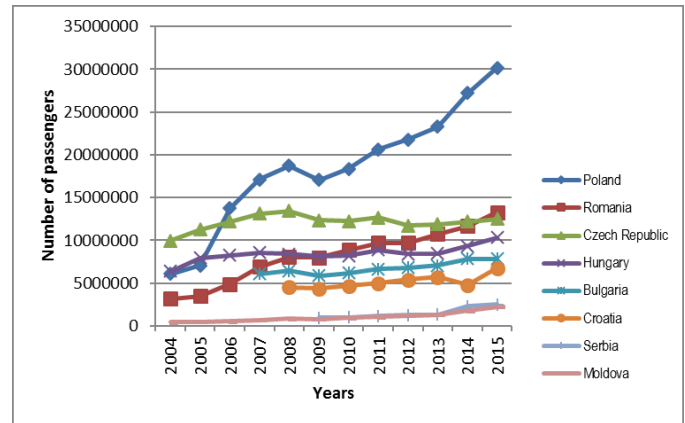

Fig 3 The evolution of passenger traffic in the 8 analyzed countries

Table 1 The dynamic of GDP and passenger traffic between 2008 and 2015

Countries	GDP growth 2008-2015 %	Passenger traffic growth 2008 – 2015 %
Poland	17.6	61
Czech Republic	6.3	-6.9
Romania	14.7	65.5
Hungary	3.04	22.2
Croatia	-8.8	49.3
Bulgaria	24.6	22.3
Serbia	4.4	415
Moldova	1.6	161.7

Similarly, at the European level, there is also a discrepancy, but in any case the GDP and the passenger traffic have an increasing trend. While the EU economy did not even grow by 3% between 2008 and 2015, passenger traffic at EU airports increased by 13,6% over the same period. In the analyzed region, we can see from table 1, there is no correlation between the dynamic of GDP and the dynamic of passenger traffic during 2008 – 2015. This is reflective of the new market dynamics, changing consumer behaviors and the increased importance of air transport for the European economy. The main reason for this weak correlation could be the following process: after 2008, the economic crisis generated an important migration of workforce from CEE to the West Europe. In parallel we are seeing an important decrease in the purchasing power and the increasing low cost offers in air transport. All these phenomena have created the premises for an important development of LCCs, which offer good prices, transforming the air transport in a more popular means of transportation, as we will demonstrate in chapter 4. Between air transport and tourism it is a permanent interaction. Aviation is indispensable for tourism, a major engine of economic growth, particularly in developing economies. Globally, 54% of international tourists travel by air. On the other hand, the tourism destination contributes to the increasing of air transport passenger. For example, the interest of tourist for summer destinations of Croatia (fig. 4) is well reflected in the seasonal character of the air traffic in this country.

While systematic differences by economic and social indicators as well as the demand for transport are clearly presented, the data suggests the following air transport market profile in the Central and Eastern Europe: fast demand growth; small and medium purchasing power of the population; mix of private and government-owned; professionally managed airlines; competitive market significantly regulated; increasingly competitive markets. Some airports and air companies are profitable and this is related to the growth of local market, to the beginning of their maturity and to the differences in government policies.

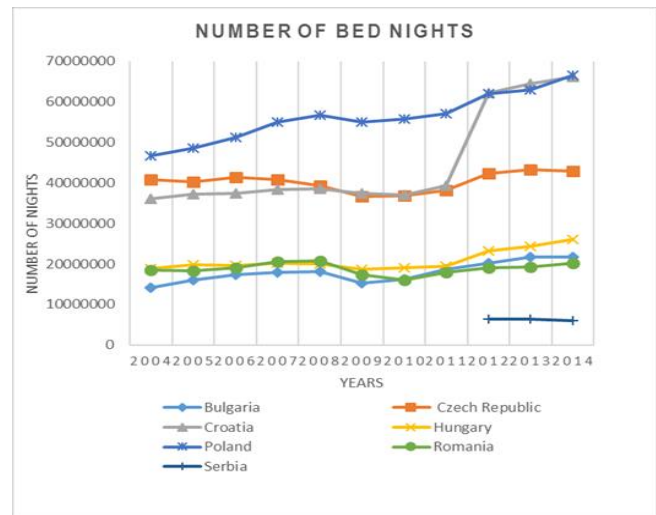

Fig. 4 Number of bed nights per country

The outcomes of this transformation of the market are: prices dropping, efficiency improving and profitability as a race between price and cost dynamics.

UNDERSTANDING THE COMPETITION

For airports there is essential understanding their competition. Which airports are in their catchment area and which airports / destinations are their competitors in different market segments: legacy company (LC), low cost company (LCC), Charter, Cargo and regional scheduled carriers. It is important to monitor their performance against their competitors and to understand their competitor's route development activities, pricing and product.

3.1.1 First and foremost, **other airports** - whether they are local, national or international, these are an airport's most direct competition as they may be able to offer customers a better location or a better cost. Their offering, location or amenities could be superior each to other, and the strength of the competitor airport based carriers must be considered.

The total number of airports in analyzed countries is presented in Fig 5 and ranges from 2 airports in Moldova to 16 in Romania. In total there are 62 airports with a traffic of 87.8 million transported passengers in 2015, with a growth by 13.9% compared to 2014, representing 4.47 % from the total European passenger traffic. By analyzing the number of airports, the average surface corresponding to an airport [9] and the average number of passengers per airport, we can conclude that the best efficient use of airports is in Czech Republic and in Poland, being important to take also in consideration the good trend of Romania, Moldova and Hungary in the past 2 years.

The top 20 airports, capitals and regionals, in terms of connectivity (table2), are repartitioned by countries as follows: 6 in Poland, 4 in Romania, 3 in Bulgaria, 3 in Croatia, 1 in Czech Republic, 1 in Hungary, 1 in Serbia and 1 in Moldova.

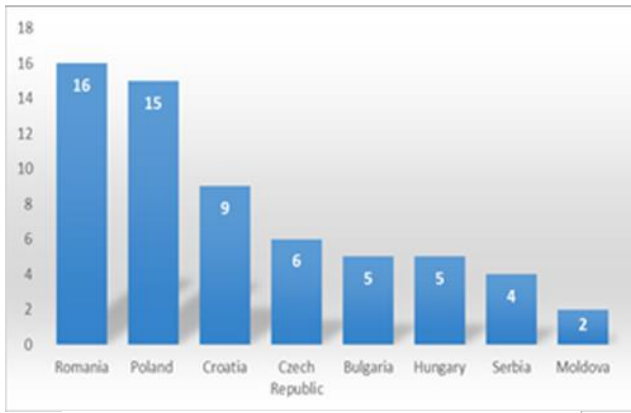

Fig. 5 The number of airports per country

According to the ACI airports classification⁵² [1], by number of passengers the analyzed airports are placed into three distinct groups as follows: in the group 2: Prague, Warsaw and Budapest (since 2015) [1]; in the group 3: Bucharest and in the group 4: Belgrade, Sofia, Zagreb, Krakow, Wroclaw, Split, Chisinau, Poznan, Dubrovnik, Katowice, Bourgas, Varna, Timisoara, Warsaw Mlodin, Cluj and Sibiu. In the CEE there are not airports in group 1. The evolution of passenger traffic for 2004 – 2015 in capital's airports from analyzed countries can be seen in fig.6.

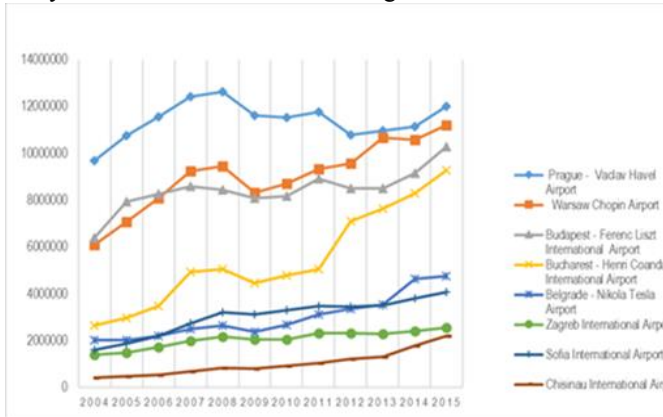

Fig. 6 Passenger traffic for capital airports for 2004 – 2015

In terms of connectivity, during 2015, Prague, Belgrade and Zagreb recorded a better position compared to 2014, while Warsaw and Bucharest lost 3 positions. In the general rank of European airports regarding the connectivity, the rank of analyzed capital airports in 2015 is the same as the classification from passenger traffic criterion, except Zagreb Airport which is much better situated in terms of connectivity than the passenger traffic criterion. Sofia airport is better ranked from passenger traffic criterion than that of the connectivity point of view.

Table 1 Connectivity and passenger traffic for capitals

Airport	Total connectivity 2014/2015	Growth of total connectivity 2004 – 2014/ 2015 vs 2014	Connectivity position in European classification 2014/2015 (ACI)	Passenger traffic in 2015	Traffic position	Traffic evolution 2015/2014 2015/2004 %
Prague (gr 2)	4162 / 4437	29 % / 7%	31 / 29	12.030.928	39	+ 7.90% + 24.07%
Warsaw (gr 2)	4265 / 4161	31 % / -2%	30 / 33	11.205.222	41	+ 5.80% + 83.69 %
Budapest (gr 2)	3121/3427	11 % /10%	41 / 41	10.289.180	48	+ 12.50% + 60.94%
Bucharest (gr 3)	3083/3231	82 % / 5%	40 / 43	9.282.884	51	+ 11.6% + 251.05 %
Belgrade (gr 4)	1887/2011	144 % / 7%	61/ 60	4.779.599	81	+ 3.00% + 126.70 %
Zagreb (gr 4)	1694/1923	59 % / 14%	67 / 64	2.577.015	110	+ 6.20% + 133.68 %
Sofia (gr 4)	1596/1725	84 % / 8%	68 / 68	4.088.942	94	+ 7.20% + 153.29 %
Chisinau (gr 4)	538/638	136 %/ 18%	122 /115	2.219.162	116	+ 24.60% + 427 %

Concerning the total airport connectivity, Prague Airport is the best with a total connectivity of 4437. This means an increase by 7% compared to 2014. Vaclav Havel Airport also recorded the highest passenger traffic of 12 030 928 in 2015. In terms of hub connectivity, Warsaw keeps the position of leader with 2217, with a decrease of 4% in 2015 compared to 2014.

The best airport in terms of the dynamics of passenger traffic is the airport of Budapest which recorded in 2015 the highest increase in passenger traffic by 12.5%, followed by the Airport of Bucharest with an increase rate of 11.6%. Between 2004 and 2015 Bucharest had a continuous increase during the whole period, having the highest growth by 251%, with also a good dynamic of total connectivity, recording a growth of 6%.

In terms of aircraft movements (fig. 7), there are many variations of the values recorded by capital airports. Bucharest, Belgrade and Chisinau have a general tendency to increase the values, Warsaw, Sofia and Zagreb keep approximately the same values and Prague and Budapest have an important tendency to decrease this number of aircraft movements. These variations correlated with the increased number of passenger and a better connectivity means a use of airplanes with a higher capacity and a better coefficient of aircraft charge.

From the regional airports category (fig. 8, table 2), Krakow's John Paul II International Airport is an excellent example of the changes that have occurred in the Polish aviation market over the last couple of decades. During 2015, Krakow

⁵² Group 1 of airports, more than 25 000 000 passengers annually

Group 2 of airports, between 10 000 000 and 25 000 000 passengers annually

Group 3 of airports, between 5 000 000 and 10 000 000 passengers annually

Group 4 of airports, less than 5 000 000 passengers annually

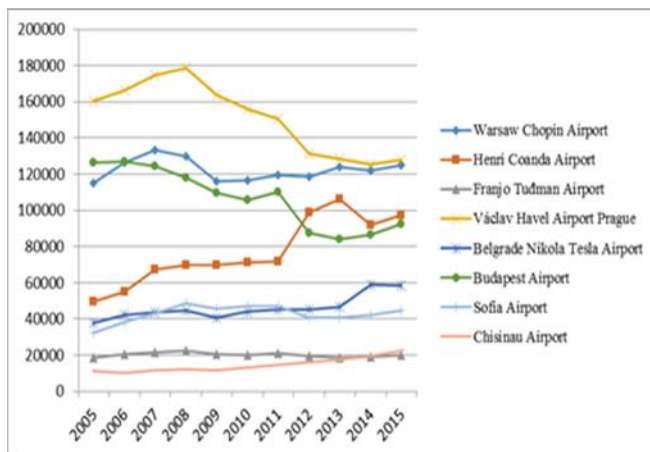

Fig. 7 The dynamic of number of aircraft movements on capital airports, 2004 - 2015

Airport welcomed a record of 4,221,171 passengers, up 11% on the previous year, and recorded the best position in total airport connectivity, 1298. It uses this performance as a platform for further expansion in the year ahead. It has already announced seven new scheduled and four new charter destinations for 2016 and forecasts traffic to exceed 4.5 million for the full calendar year.

Table 2 Airport connectivity and passenger traffic for 12 regional airports

Airport	Connectivity position 2014/2015	Total Connectivity in 2014/2015	Passenger traffic 2015	Traffic Position	Traffic evolution 2015/2014 2015/ 2004
Krakow (Po)	81 / 83	1188/1298	4221171	93	+ 10.60% / 401.84%
Wroclaw (PO)	123 / 111	534/663	2320000	115	+ 11.23% / 552.72%
Split (Hr)	125 / 113	522 / 660	1955400	124	+ 11.56% / 151.08%
Poznan (PO)	120/ 119	554 / 596	1500918	134	+ 3.80% / 334.17%
Dubrovnik (Hr)	124 / 125	532/570	1693934	131	+ 6.90% / 92.28%
Katowice (PO)	152	340/455	3069278	104	+ 13.85% / 392.96%
Bourgas (BG)	204/189	177/224	2336752	114	- 6.70% / 74.10%
Varna (BG)	201/ 192	187 / 230	1398694	138	+0.80% / 6.03 %
Timisoara (RO)	190 / 194	240/224	924463	149	+25.80% / 129.36%
Warsaw Modlin (PO)	229/ 201	144/214	2588175	110	+51.95% / 201.83 %
Cluj Napoca (RO)	206/ 210	175/194	1487603	135	+ 25.80% / 736.38%
Sibiu	207 / 221	175/172	307026	181	+ 22.60% / 527.91 %

Wroclaw had also a good evolution in connectivity in 2015 arriving in the second position, winning 12 positions in the general ranking of European airports, but in terms of passenger traffic is only the fifth. In 2015, other airports with a good evolution in connectivity and passenger traffic are Split, Bourgas and Warsaw Mlodin.

Cluj Airport (Romania) is one other good example of the changes that have occurred in the Romanian aviation market

over the last decade. Cluj welcomed in 2015 a record increase compared to 2014 by 25.8% and by 736% compared to 2004. Cluj Airport w also a good airport connectivity in 2015 in its ACI airport group.

The most important evolutions between 2004 and 2015, in terms of passenger traffic, there are those of the following airports (Fig 8): Cluj Napoca 736%, Wroclaw 553%, Sibiu 528%, Krakow 402% and Katowice 393%. In general the increase in passenger traffic is more important than the increase in connectivity. In the table 2, we present the positions of these 12 airports from the point of view of connectivity and passenger traffic.

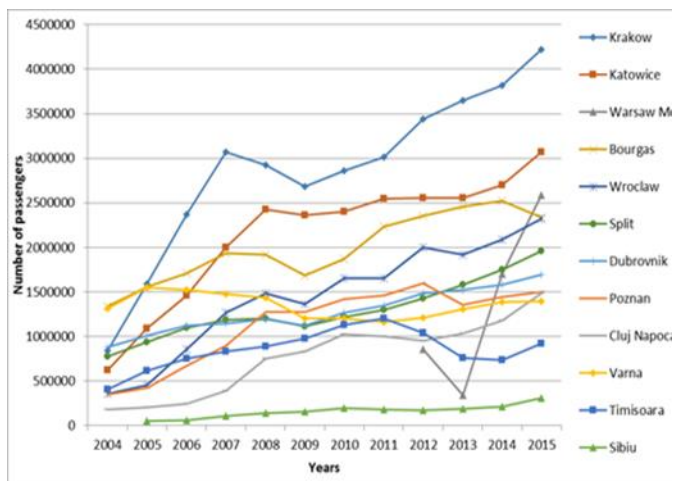

Fig. 8 The dynamic passenger traffic for top 12 airports non capitals within period 2004 - 2015

3.1.2 The airports are in direct competition with other transport options, such as rail, road, ferry or coach because they might be more convenient for the potential customer, or they could be more cost effective. The speed in which the customer can reach their destination will also be considered. The threat of other substitutes has in the past played a moderate role, but has started to become more significant in some segments. Substitution depends on the relative cost/benefit profile of other modes of transport/communication relative to air transport. Aircraft are still in a class of their own in terms of speed of travel and have seen their real costs drop significantly over the last decades. However, the time and inconvenience of security measures have reduced the overall attractiveness of scheduled airline transport relative to substitutes. The significant drop in the real cost of air transportation has increased the advantage of air travel versus substitutes, and further technological improvements are likely. Government policies affecting the attractiveness of alternative modes of travel or communication affect the impact of substitutes on airlines.

High-speed trains for European short haul provide increasing competition on point-to-point connections. There is significant political pressure for this type of substitution to occur, with the use of policy tools likely to be intensified until a desired level of substitution has occurred. For short-haul connections, a key concern of airline passengers is punctuality. While airlines have some influence, the key drivers for delays are the air control system and airports.

Private jets on time-share programs offer some competition to business and first class travel on scheduled connections, especially at the very top end of the market and to locations with low density of traffic.

3.1.3 Communications technology, be it video conference, Skype, FaceTime and other communications platforms. Advances in technology have the potential to reduce the requirements for travel. Phone/Web/Video conference technology provides increasingly high quality at falling costs.

UNDERSTANDING THEIR CUSTOMERS

The airport has to analyze their most important customers are and their different types of business models. It is necessary that airports understand the varying aspects of the airline and where to acquire their information on the targets.

The airport – airlines interaction in CEE

The new, dynamic nature of the European aviation market has led to a fundamental change: it has transformed the traditional business relationship between airport and airline. As an airport or destination the most important customers are the airlines and tour operators that serve their market, bringing in passengers and visitors to the airport market.

There are a number of different airline business models that have varying needs, from full service carriers (LC), charter airlines, low cost carrier airlines and ultra-low cost operators. Understanding the airline involves understanding: fleet, network, scheduling priorities, operational requirements, financial support, the market fit, geographical fit, brand strength in the market place.

To succeed in route development, the airport has to appreciate the difference between airline types –legacy carriers and low cost carriers (LCCs) and adapt pitch approach accordingly. LCs can be divided up into different types. Network carriers can be single hub, like Air France at Paris CDG or Emirates in Dubai; or they can be a multiple hub carrier like American Airlines and Lufthansa. Usually a carrier has multiple hubs for geographical reasons. Legacy carriers can be point-to-point regional carriers also. LCCs can be segmented too: LCCs, like Azul and EasyJet, which go after the business market; ultra-low cost carriers (ULCCs) aim for the lowest fares and have succeeded in stimulating new unserved routes. LCs offer their own LCC subsidiaries; they offer customers a cheaper or more basic service in order to keep and gain more customers. Charter carriers can open new markets and also provide links to hub networks. The nature of airline models is constantly evolving. Airports keep up to speed with new variants, partnerships and adaptations to strengthen their target setting and route development approach.

The European short-haul and medium-haul market is supplied by legacy carriers (national flag carriers and charter airlines) and a generally younger group of low-cost airlines. Low-cost airlines such as Ryanair, Easy Jet, Wizz Air benefit from relatively simple business models, higher aircraft utilization and staff productivity rates and therefore lower costs than their legacy rivals. This provides low-cost airlines with a competitive advantage which enables them to offer significantly lower fares and therefore attract a growing share of the air travel market.

The LCCs, have changed the European aviation market which has become much more dynamic with frequent, rapid change taking place within it. The big LCC's especially have continued to add large numbers of aircraft to what were by the 2015, already large fleets. This has meant every year not only introducing a large number of new routes, for example Ryanair having nearly 1600 routes in 2016 and Wizz Air, the bigger East Europe LLC 420 routes, but also a continual process of establishing new bases from which to operate the newly acquired aircraft, seeking the best financial return in

the process. Some of these bases are located at well-established airports, sometimes capital city airports, but many are at regional airports. Ryanair from its 78 total bases, has already many bases in Eastern and Central Europe as for example in Budapest, Warsaw, Krakow, Wroclaw, Sofia, Prague Timisoara, Bucharest.

Low cost companies are the main actor in the increasing traffic in the countries from Central and Eastern Europe. For the majority of capitals of the analyzed countries, the number of destinations operated in 2015 by LCC is bigger than the number of destinations operated by legacy companies (LC). The situation is presented in table 3.

Table 3 Number of air companies on airports capitals

Airport	Total air companies	Low cost companies (LCC)		Legacy companies (LC)	
		Number	Destinations	Number	Destinations
Prague	65	38	120	27	83
Warsaw	45	24	120	21	63
Budapest	37	14	74 Ryanair 22	23	27
Bucharest	33	15	88 Wizz Air 40 Blue Air 29	24	53 (Tarom 34)
Belgrade	28	16	27	12	51
Zagreb	25	9	16	16	34
Sofia	25	7	28	18	33
Chisinau	18	6	13	10	35

We have a similar situation, a much bigger number of destinations operated by LCC, on the regional airports which have the most important growth in terms of passenger traffic during 2004 – 2015. The situation of market share between the LCs and LLCs are presented in the table 4. This important number of destinations served on Budapest and Katowice is due to the fact that this two airports are the main bases of Wizz Air. Budapest being also a base of Ryanair. Bucharest is base of Wizz Air, but also the main base of the Romanian LCC Blue Air.

The table 5 shows the Company's ranking by low-cost market share in each of the analyzed countries [13].

Further, we present the main performances of Wizz Air, Ryanair, Easy Jet and Blue Air which are the main actors of the LCC model in CEE.

The main airliner actors of low cost model in CEE

Wizz Air, from its modest beginnings, in 2003, it has grown

Table 4 Number of air companies on regional airports

Airport	Total air companies	Low cost companies (LCC)		Legacy companies (LC)	
		Number	Destinations	Number	Destinations
Kracovia	15	6	58 Ryanair 35 Easy Jet 12 Others 11	14	11
Katowice	5	3	38, Wizz Air 34 Ryanair 3, Transavia 1	2	2
Warszovia Modlin	1	1 (Ryanair)	40	0	0
Bourgas	69	66	122 (120 – S)	3	4 (2 – S)
Wroclaw	6	4	33, Ryanair 21 Wizz Air 8, Others 4	3	4
Split	38	27	80 (76 S)	11	35 (30 S)
Dubrovnik	37	28	65	9	27
Poznan	5	2	22	3	4
Cluj	5	3	38, Wizz Air 27, Blue Air 10, other 1	5	6
Timișoara	5	3	24, Ryanair 7, Wizz Air 15, Blue Air 2	2	2
Sibiu	5	2	9, Wizz Air 7, Blue Air 1	3	3

Table 5 The market share of the first three LCCs in the CEE and by country market [13]

Market carrier	Number 1		Number 2		Number 3	
	Carrier	Share	Carrier	Share	Carrier	Share
CEE	Wizz Air	39.2%	Ryanair	29.4%	EasyJet	7.4%
Poland	Ryanair	50.7%	Wizz Air	37.5%	Norwegian	5.5%
Romania	Wizz Air	67.7%	Blue Air	22.5%	Ryanair	4.8%
Hungary	Wizz Air	50.5%	Ryanair	21.8%	Easy Jet	9.0%
Czech Republic	Easy Jet	29.2%	Wizz Air	14.5%	Ryanair	13.9%
Bulgaria	Wizz Air	77.3%	Easy Jet	15.4%	Norwegian	3.8%
Serbia	Wizz Air	57.9%	Easy Jet	16.0%	Pegasus Airlines	8.4%

to become Central and Eastern Europe's leading low cost airline. In the 2015 financial year Wizz Air transported 16.5 million passengers, a cumulative increase of 101 per cent. over the last five years. During the course of the year it operated over 348 routes and at the end of the year it had a fleet of 55 Airbus A320 aircraft and employed more than 2,100 people. Wizz Air's ultra-low cost model gives it a clear cost advantage versus most of its rivals, including many other low-cost airlines, and as a result it is able to stimulate the market with very low fares and sustain a relatively high growth rate compared to other airlines.

Wizz Air's premium growth rate is also a function of the market in which it operates: Central and Eastern Europe. All of Wizz Air's routes connect to CEE countries where economic growth, and therefore growth in demand for air travel, is generally stronger than in Western Europe. The demand for air travel in CEE has increased more than five-fold in the last ten years and as a result, Wizz Air has grown to be not only the largest low cost airline in CEE but also the fourth largest independent low-cost airline in Europe after Ryanair, Easyjet and Norwegian Air Shuttle as measured by the number of passengers carried[13].

At present, Wizz Air has operations in 16 CEE countries with an aggregate population of 295 million. It serves the market by offering a network of 22 bases and 110 destinations. The 22 bases are located in: Poland (17 aircrafts), Romania (15 aircrafts), Hungary (7 aircrafts), Bulgaria (4 aircrafts), Lithuania (3 aircrafts), Ukraine (2 aircrafts), Czech Republic (1 aircraft), Latvia (1 aircraft), Bosnia and Hertzegovina (1 aircraft), Macedonia (2 aircrafts), Serbia (1 aircraft). The Company also offers services from 15 CEE cities where it does not base aircraft and crews.

This success could be the result of a very good match between the ultra-low cost business model offered by Wizz Air and the demand of CEE market and as such the Company offers safe, reliable operations, low fares and hassle-free services and a distinctive brand designed to appeal to the whole market. This approach has enabled the Company to become the number one or number two low-cost airline in all of its base countries. The Company's aggregate market share in CEE reached 39.2 % in the 2015 financial year, up from 35.6% in 2010 [13].

Ryanair's largest base is at London-Stansted in the United Kingdom with 43 aircraft followed by its home base at Dublin. Ryanair operates from 84 bases connecting 33 countries across Europe and North Africa, some of which only base a single aircraft [7]. Several non-base airports serve more flights and/or destinations than certain base airports. In CEE, Ryanair has 3 bases in Poland: Warsaw with 48 destinations, Krakow with 36 destinations, Wroclaw with 27 destinations and 2 bases in Romania: Bucharest with 12 destinations and Timișoara with 7 destinations.

Ryanair traditionally prefers to fly to smaller or secondary airports usually outside major cities to help the company benefit from lower landing fees and quick turn-around times to reduce costs. In 2013 it already became apparent that Ryanair was starting to initiate a shift from its typical secondary (low-cost) airports to a more significant presence at major airports, following the Easy Jet model.

Today **EasyJet** is the second-largest short-haul airline in Europe, carrying almost 70 million passengers per year with its innovative approach and friendly customer service. His network extends across Europe and beyond, flying to 136 airports in 31 different countries, operating 735 routes.

The key points of his business model are high aircraft utilization, quick turnaround times, charging for extras (such as priority boarding, hold baggage and food) and keeping operating costs low [5]. One main difference EasyJet, Ryanair and Wizz Air have from Southwest is the three fly a young fleet of aircraft. Southwest has an average fleet age of 11.9 years [5], whereas Ryanair's and EasyJet's average fleet ages are just a little over five years each [12] and Wizz Air even around four years[13]. While the three airlines share a common business charter and concept, EasyJet's strategy differs from Ryanair's and Wizz Air in several areas. The most noticeable is that EasyJet flies mainly to the primary airports in the cities that it serves, for the convenience of passengers, while Ryanair and Wizz Air often choose secondary airports to further reduce costs.

Blue Air is a Romanian low-cost airline, with 100% Romanian capital, founded in 2004, headquartered in

Bucharest, with its main hubs at Henri Coandă International Airport and Turin Airport [11]. As of May 2016, Blue Air flies to 48 destinations in 12 European countries, arriving to carry in the first six months of 2016, 1.42 million of passengers, with an increase by 82% over the same period of 2015. Blue Air currently has 26 aircraft in the fleet, located in 5 bases: Bucharest with 29 destinations, Larnaca with 22 destinations, Torino with 17 destinations, Iasi and Bacau, each of them with 10 destinations. A comparison of the number of passenger carried by the 4 companies is shown in the figure 9.

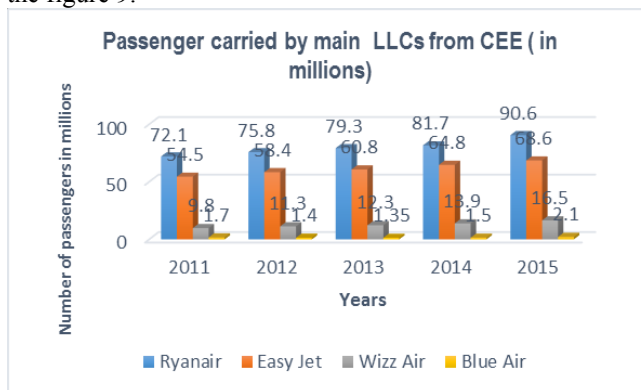

Fig. 9 Passenger carried by the main LCCs from CEE

Despite this significant capacity expansion of the LCCs, the 4 companies are able to increase their average load factor each year (fig 10).

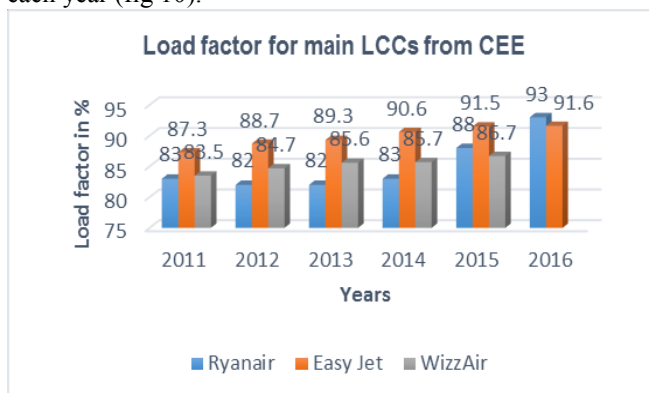

Fig 10 Load factor of LCCs from CEE

CONCLUSIONS

In the last 12 years, one can notice a very important increase in passenger traffic and in airport connectivity in the Central and Eastern Europe which comprises 21 countries with a total population of over 550 million people.

The growth of traffic in the region is due especially to the low cost companies which have modified the air transport market and the competition between airports for attracting new airlines and opening new routes. However, as this market is relatively under-served by airlines and in particular low-cost airlines, it represents a huge opportunity for a low-cost airline.

The work force in migration from East to West represent an important target group of LCCs which have had an important development in the region contributing to the

growth of passenger traffic and of the airport connectivity. This development of LCCS which are starting new regional routes with an important speed, are changing the geography of routes and this fact could soon have an important impact on the development of hubs as well.

The traffic in the 8 analyzed countries is based essentially on the traffic of airports from capital cities. For example in 2015, from the total passenger traffic of these countries, 64.31% of the traffic is on the capital airports. Between the top other 12 airports non-capitals, Poland has 5 airports, Romania 3, Bulgaria 2 and Croatia 2, while Czech Republic, Hungary, Serbia and Moldova have no airport. Furthermore, for example, the passenger traffic on Budapest airport is 99.31% from Hungary traffic and on Prague is 96.27% from the traffic of Czech Republic.

In understanding its competition an airport should have insight into its market position and where it ranks. It is important to develop a clear, credible position and brand to deliver success in an increasingly competitive industry.

REFERENCES

- [1] ACI EUROPE Airport Traffic Report, December, Q4 and Full Year 2015
- [2] Airport Council International – Europe , Airport Industry Connectivity Report, 2015

- [3] ATAG, “Aviation benefits beyond borders”, 2016
- [4] Eurostat 2014, 2015.
- [5] Easy Jet, Annual report and accounts 2015
- [6] IATA, Vision 2050, Singapore, 12 February 2011
- [7] Ryanair annual report 2016
- [8] S.E. Zaharia, “Connectivity, a complex indicator of airport industry evolution”, Romanian Airport Association Bulletin, 2014, pp. 5- 16
- [9] S.E. Zaharia, “Benchmarking of airports from Central and Eastern Europe”, proceedings of International Conference on Air transport, INAIR 2015, Amsterdam.
- [10] S.E. Zaharia, The relationship airports - airlines in a competitive and complex economic environment, RAA conference, October 2016
- [11] https://en.wikipedia.org/wiki/Blue_Air
- [12] <https://en.wikipedia.org/wiki/EasyJet>
- [13] WizzAir Holdings, Annual report and accounts 2015

AUTHOR INFORMATION

Sorin Eugen ZAHARIA, Professor, Faculty of Aircraft Engineering, University “Politehnica” of Bucharest

INAIR Publication Ethics & Publication Malpractice Statement

INAIR - INTERNATIONAL CONFERENCE ON AIR TRANSPORT

Ethical guidelines for journal publication

These guidelines are based on existing Elsevier policies.

The publication of an article in the peer-reviewed journal “INTERNATIONAL CONFERENCE ON AIR TRANSPORT” (INAIR) contributes to growth of knowledge in the field of air transportation. We encourage the best practices and standards of publication ethics and take all possible measures against publication malpractices. It is important to agree upon standards of proper ethical behavior for all parties involved in the act of publishing: authors, editors, peer reviewers and the publisher. EDIS, publishing house of the University of Zilina and the Air Transport Department of the Faculty of Operation and Economics of Transport and Communications, University of Zilina, as publishers of the journal INAIR, take their duties of guardianship over all stages of publishing extremely seriously and we recognize our ethical and other responsibilities.

Duties of authors

(These guidelines are based on existing Elsevier policies and COPE’s Best Practice Guidelines for Journal Editors.)

Reporting standards

Authors of papers should present an accurate account of the work performed as well as an objective discussion of its significance. Underlying data should be represented accurately in the paper. A paper should contain sufficient detail and references to permit others to replicate the work. Fraudulent or knowingly inaccurate statements constitute unethical behavior and are unacceptable. Review and professional publication articles should also be accurate and objective, and editorial „opinion“ works should be clearly identified as such.

Data access and retention

Authors may be asked to provide the raw data in connection with a paper for editorial review, and should be prepared to provide public access to such data (consistent with the ALPSP-STM Statement on Data and Databases), if practicable, and should in any event be prepared to retain such data for a reasonable time after publication.

Originality and plagiarism

The authors should ensure that they have written entirely original works, and if the authors have used the work and/or words of others, that this has been appropriately cited or quoted. Plagiarism takes many forms, from „passing off“ another’s paper as the author’s own paper, to copying or paraphrasing substantial parts of another’s paper (without attribution), to claiming results from research conducted by others. Plagiarism in all its forms constitutes unethical publishing behavior and is unacceptable.

Multiple, redundant or concurrent publication

An author should not in general publish manuscripts describing essentially the same research in more than one journal or primary publication. Submitting the same manuscript to more than one journal concurrently constitutes unethical publishing behavior and is unacceptable. In general, an author should not submit for consideration in another journal a previously published paper. Publication of some kinds of articles (e.g. clinical guidelines, translations) in more than one journal is sometimes justifiable, provided certain conditions are met. The authors and editors of the journals concerned must agree to the secondary publication, which must reflect the same data and interpretation of the primary document. The primary reference must be cited in the secondary publication.

Acknowledgement of sources

Proper acknowledgment of the work of others must always be given. Authors should cite publications that have been influential in determining the nature of the reported work. Information obtained privately, as in conversation, correspondence, or discussion with third parties, must not be used or reported without explicit, written permission from the source. Information obtained in the course of confidential services, such as refereeing manuscripts or grant applications, must not be used without the explicit written permission of the author of the work involved in these services.

Authorship of the paper

Authorship should be limited to those who have made a significant contribution to the conception, design, execution, or interpretation of the reported study. All those who have made significant contributions should be listed as co-authors. Where there are others who have participated in certain substantive aspects of the research project, they should be acknowledged or listed as contributors. The corresponding author should ensure that all appropriate co-authors and no inappropriate co-authors are included on the paper, and that all co-authors have seen and approved the final version of the paper and have agreed to its submission for publication.

Hazards and human or animal subjects

If the work involves chemicals, procedures or equipment that have any unusual hazards inherent in their use, the author must clearly identify these in the manuscript. If the work involves the use of animal or human subjects, the author should ensure that the manuscript contains a statement that all procedures were performed in compliance with relevant laws and institutional guidelines and that the appropriate institutional committee(s) has approved them. Authors should include a statement in the manuscript that informed consent was obtained for experimentation with human subjects. The privacy rights of human subjects must always be observed.

Disclosure and conflicts of interest

All authors should disclose in their manuscript any financial or other substantive conflict of interest that might be construed to influence the results or interpretation of their manuscript. All sources of financial support for the project should be disclosed. Examples of potential conflicts of interest which should be disclosed include employment, consultancies, stock ownership, honoraria, paid expert testimony, patent applications/registrations, and grants or other funding. Potential conflicts of interest should be disclosed at the earliest stage possible.

Fundamental errors in published works

When an author discovers a significant error or inaccuracy in his/her own published work, it is the author's obligation to promptly notify the journal editor or publisher and cooperate with the editor to retract or correct the paper. If the editor or the publisher learns from a third party that a published work contains a significant error, it is the obligation of the author to promptly retract or correct the paper or provide evidence to the editor of the correctness of the original paper.

Duties of editors

(These guidelines are based on existing Elsevier policies and COPE's Best Practice Guidelines for Journal Editors.)

Publication decisions

The editor of a peer-reviewed journal INAIR is responsible for deciding which of the articles submitted to the journal should be published, often working in conjunction with the relevant society (for society-owned or sponsored journals). The validation of the work in question and its importance to researchers and readers must always drive such decisions. The editor may be guided by the policies of the journal's editorial board and constrained by such legal requirements as shall then be in force regarding libel, copyright infringement and plagiarism. The editor may confer with other editors or reviewers (or society officers) in making this decision.

Fair play

An editor should evaluate manuscripts for their intellectual content without regard to race, gender, sexual orientation, religious belief, ethnic origin, citizenship, or political philosophy of the authors.

Confidentiality

The editor and any editorial staff must not disclose any information about a submitted manuscript to anyone other than the corresponding author, reviewers, potential reviewers, other editorial advisers, and the publisher, as appropriate.

Disclosure and conflicts of interest

Unpublished materials disclosed in a submitted manuscript must not be used in an editor's own research without the express written consent of the author. Privileged information or ideas obtained through peer review must be kept confidential and not used for personal advantage. Editors should recuse themselves (i.e. should ask a co-editor, associate editor or other member of the editorial board instead to review and consider) from considering manuscripts in which they have conflicts of interest resulting from competitive, collaborative, or other relationships or connections with any of the authors, companies, or (possibly) institutions connected to the papers. Editors should require all contributors to disclose relevant competing interests and publish corrections if competing interests are revealed after publication. If needed, other appropriate action should be taken, such as the publication of a retraction or expression of concern.

Involvement and cooperation in investigations

An editor should take reasonably responsive measures when ethical complaints have been presented concerning a submitted manuscript or published paper, in conjunction with the publisher (or society). Such measures will generally include contacting the author of the manuscript or paper and giving due consideration of the respective complaint or claims made, but may also include further communications to the relevant institutions and research bodies, and if the complaint is upheld, the publication of a correction, retraction, expression of concern, or other note, as may be relevant. Every reported act of unethical publishing behavior must be looked into, even if it is discovered years after publication.

Duties of reviewers

(These guidelines are based on existing Elsevier policies and COPE's Best Practice Guidelines for Journal Editors.)

Contribution to editorial decisions

Peer review assists the editor of INAIR in making editorial decisions and through the editorial communications with the author may also assist the author in improving the paper. Peer review is an essential component of formal scholarly communication, and lies at the heart of the scientific method. INAIR shares the view of many that all scholars who wish to contribute to publications have an obligation to do a fair share of reviewing.

Promptness

Any selected referee who feels unqualified to review the research reported in a manuscript or knows that its prompt review will be impossible should notify the editor and excuse himself from the review process.

Confidentiality

Any manuscripts received for review must be treated as confidential documents. They must not be shown to or discussed with others except as authorized by the editor.

Standards of objectivity

Reviews should be conducted objectively. Personal criticism of the author is inappropriate. Referees should express their views clearly with supporting arguments.

Acknowledgement of sources

Reviewers should identify relevant published work that has not been cited by the authors. Any statement that an observation, derivation, or argument had been previously reported should be accompanied by the relevant citation. A reviewer should also call to the editor's attention any substantial similarity or overlap between the manuscript under consideration and any other published paper of which they have personal knowledge.

Disclosure and conflict of interest

Unpublished materials disclosed in a submitted manuscript must not be used in a reviewer's own research without the express written consent of the author. Privileged information or ideas obtained through peer review must be kept confidential and not used for personal advantage. Reviewers should not consider manuscripts in which they have conflicts of interest resulting from competitive, collaborative, or other relationships or connections with any of the authors, companies, or institutions connected to the papers.

CONFERENCE PARTNERS



Air Navigation Services
of the Czech Republic



Name of publication INAIR 2016
Type of publication Proceedings from the international conference INAIR 2016
 Vienna, 10 - 11 November 2016
Issued by EDIS - Publishing Centre of University of Žilina
Year 2016/First edition
Print Run 90 pcs
Edited by Dr. Martin Hromádka
 ISBN 978-80-554-1273-3
 ISSN 2454-0471

Contact University of Žilina
 Air Transport Department
 Univerzitná 8215/1
 010 26 Žilina, Slovakia

All papers in these proceedings were subject to peer review by the members of Scientific Board.

© The Faculty of Operation and Economics of Transport and Communications, University of Zilina Air Transport Department, 2016